

> Specification sheet



Our energy working for you.™

Description

C-Series engines have established an unrivalled reputation for reliability. Engines in the series incorporate features to reduce maintenance and enhance performance in order to meet the most demanding requirements of generator set operation..



This engine has been built to comply with CE certification.



This engine has been designed in facilities certified to ISO9001 and manufactured in facilities certified to ISO9001 or ISO9002.

Features

Coolpac Integrated Design - Supplied with cooling package and air cleaner kit for a complete power package.

Single Poly Vee belt drive for fan, alternator and water pump, with self-tensioning idler for minimum maintenance.

Inline-type Bosch P-Series pump operates at high injection pressures for cleaner combustion and lower emissions.

Spin-on fuel filter and full-flow lubricating oil filter.

Top mounted Holset HX40W turbo- charger for increased power, fuel economy, and lower smoke and noise levels.

Service and Support - G-Drive products are backed by an uncompromising level of technical support and after sales service, delivered through a world class service network.

1500 rpm (50 Hz) Ratings

Gross Engine Output			Net Engine Output			Typical Generator Set Output					
Standby	Prime	Base	Standby	Prime	Base	Standby (ESP)		Prime (PRP)		Base (COP)	
kWm/BHP			kWm/BHP			kWe	kVA	kWe	kVA	kWe	kVA
180/241	163/219	133/178	175/234	158/211	128/171	160	200	146	182	119	149

1800 rpm (60 Hz) Ratings

Gross Engine Output			Net Engine Output			Typical Generator Set Output					
Standby	Prime	Base	Standby	Prime	Base	Standby (ESP)		Prime (PRP)		Base (COP)	
kWm/BHP			kWm/BHP			kWe	kVA	kWe	kVA	kWe	kVA
207/277	188/252	159/213	199/266	180/241	151/202	175	219	160	200	139	173

General Engine Data

Type	4 cycle, in-line, Turbo Charged
Bore mm	114 mm (4.49 in.)
Stroke mm	135 mm (5.32 in.)
Displacement Litre	8.3 litre (505.0 in. ³)
Cylinder Block	Cast iron, 6 cylinder
Battery Charging Alternator	60 amps
Starting Voltage	24 volt, negative ground
Fuel System	Direct injection
Fuel Filter	Spin-on fuel filters with water separator
Lube Oil Filter Type(s)	Spin-on full flow filter
Lube Oil Capacity (l)	23.8
Flywheel Dimensions	2/11.5

Coolpac Performance Data

Cooling System Design	Jacket Water After Cooled
Coolant Ratio	50% ethlene glycol; 50% water
Coolant Capacity (l)	26.0
Limiting Ambient Temp.**	55.0
Fan Power	1.3
Cooling system air flow (m ³ /s)**	3.7
Air Cleaner Type	Dry replaceable element with retriiction indicator

** @ 13 mm H₂O

Weights & Dimension

Length	Width	Height	Weight (dry)
mm	mm	mm	kg
1417	831	1255	769

Fuel Consumption 1500 (50 Hz)

%	kWm	BHP	L/ph	US gal/ph
Standby Power				
100	180	241	45	11.9
Prime Power				
100	163	219	40	10.7
75	122	164	30	7.9
50	82	110	20	5.3
25	41	55	11	2.9
Continuous Power				
100	133	178	32	8.5

Fuel Consumption 1800 (60 Hz)

%	kWm	BHP	L/ph	US gal/ph
Standby Power				
100	207	277	53	14.1
Prime Power				
100	188	252	48	12.6
75	141	189	35	9.2
50	94	126	24	6.4
25	47	63	14	3.6
Continuous Power				
100	159	213	40	10.5

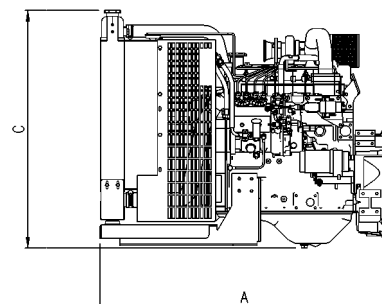
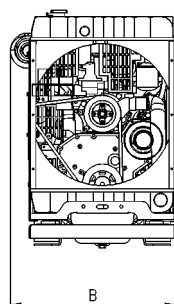

Ratings Definitions

Emergency Standby Power (ESP):

Applicable for supplying power to varying electrical load for the duration of power interruption of a reliable utility source. Emergency Standby Power (ESP) is in accordance with ISO 8528. Fuel Stop power in accordance with ISO 3046, AS 2789, DIN 6271 and BS 5514.

Limited-Time Running Power (LTP):

Applicable for supplying power to a constant electrical load for limited hours. Limited-Time Running Power (LTP) is in accordance with ISO 8528.

Prime Power (PRP):

Applicable for supplying power to varying electrical load for unlimited hours. Prime Power (PRP) is in accordance with ISO 8528. Ten percent overload capability is available in accordance with ISO 3046, AS 2789, DIN 6271 and BS 5514.

Base Load (Continuous) Power (COP):

Applicable for supplying power continuously to a constant electrical load for unlimited hours. Continuous Power (COP) is in accordance with ISO 8528, ISO 3046, AS 2789, DIN6271 and BS 5514.