

Specifications and types



Zone 2 - Zone 22 II 3G Ex h IIB T4 Gc e II 3D Ex h IIB T135°C Dc X
Zone 1 - Zone 21 II 2G Ex h IIB T4 Gb e II 2D Ex h IIB T135°C Db X
Zone M2 I M2 Ex h I Mb X*

Ex h IIB T4 Gb e Ex h IIB T135°C Db

* The string relating to mining applications is not applicable to aluminium BOXER range pumps

Suction / delivery connections	1/2" f BSPP (*)
Air fitting	3/8" f BSPP
Max. flow rate*	35 l/min
Max. supply air pressure	8 bar
Max. head*	80 m
Max negative suction head - dry-running**	3 m
Max negative suction head - with pump primed	9,5 m
Max. diameter suspended solids	2 mm
Noise	65 dB

(*) NPT fittings only on request

* The curves and the performances refer to pumps with immersed suction and open delivery outlet, with water at 20°C and vary depending on material composition.

** The value depends on the pump configuration.



PLASTIC MATERIAL - PP (GF/CF)

Boxer 35



Maximum dimensions

Height	168 mm
Width	288 mm
Depth	120 mm



Construction mat. (casing and manifolds) and net weight

POLYPROPYLENE (with glass additive)	1,8 Kg Temp. 3°C min. 65°C max
---	--------------------------------------

CONDUCTIVE POLYPROPYLENE (with carbon additive)	Temp. 3°C min. 65°C max
---	----------------------------

PLASTIC MATERIAL - PVDF

Boxer 35



Maximum dimensions

Height	168 mm
Width	288 mm
Depth	120 mm



Construction mat. (casing and manifolds) and net weight

PVDF (with carbon additive)	1,98 Kg Temp. 3°C min. 95°C max
---------------------------------------	---------------------------------------

Specifications and types



Zone 2 - Zone 22
Zone 1 - Zone 21
Zone M2

II 3G Ex h IIB T4 Gc e II 3D Ex h IIB T135°C Dc X
II 2G Ex h IIB T4 Gb e II 2D Ex h IIB T135°C Db X
I M2 Ex h I Mb X*

Ex h IIB T4 Gb e Ex h IIB T135°C Db

* The string relating to mining applications is not applicable to aluminium BOXER range pumps

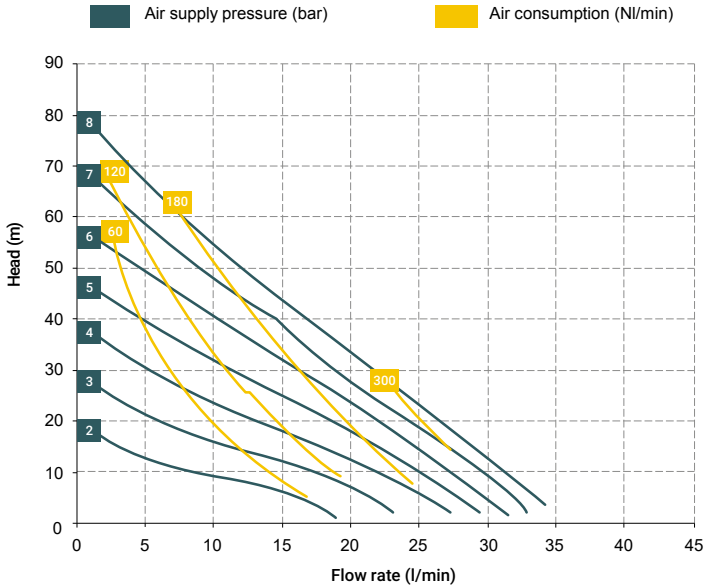

* The curves and performances refer to pumps with immersed suction and open delivery outlet with water at 20 °C and vary according to the composition materials.

MONOSTABLE distributor material (Distributor + spool) - (compressed air circuit)

- POM

Core material

- Polypropylene
- PP+CF

Diaphragm materials

- PTFE
- HYTREL®
- SANTOPRENE
- NBR

Cap materials

- Polypropylene (with glass filler)
- Conductive polypropylene (with carbon filler)
- PVDF

Ball materials

- PTFE
- AISI 316 L
- EPDM
- NBR

O-ring materials

- EPDM
- NBR
- VITON®
- PTFE

Accessories

- Equaflux 51 (For damper materials, please refer to the technical data sheet)
- Foot valve
- Air regulation kit W1000-8-G
- Batch controller
- Stroke counter
- Reinforcement rings
- Flange kit (DIN flanges - ANSI on request)

Any colour variations in our polypropylene and PVDF products are due to the special blends of the raw materials used. The use of high levels of glass and long-fiber carbon filler result in a unique colour that does not in any way affect the quality of the product; on the contrary, it points to the high level of content used to ensure outstanding performance.

BOXER 35 (PP):

A1 - A2 - A4 - M1 - M2 - M4

BOXER 35 (PVDF):

A1 - A2 - A4 - M1 - M2 - M4

Standard fittings:

- Suction: A1
- Delivery: M1

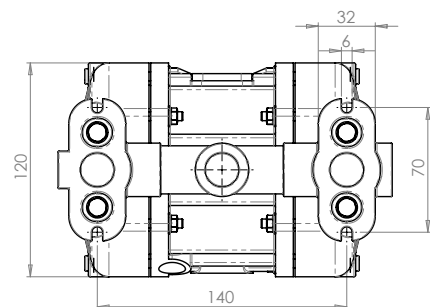
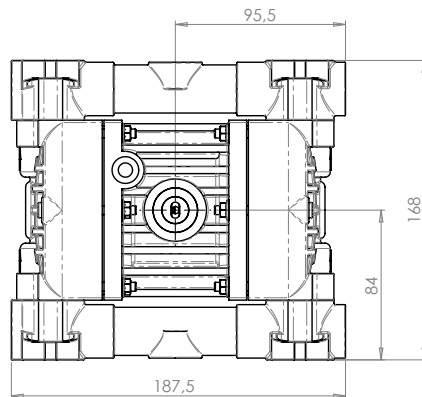
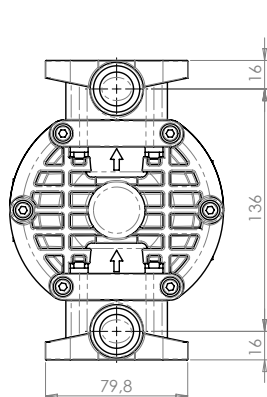
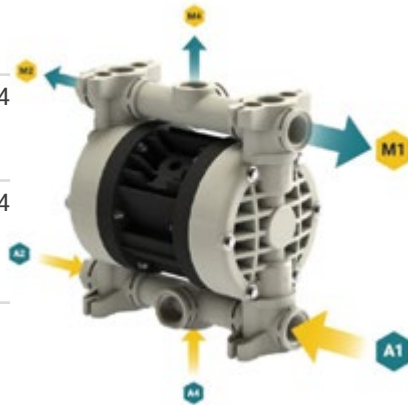

Specifications and types



Zone 2 – Zone 22 II 3G Ex h IIB T4 Gc e II 3D Ex h IIB T135°C Dc X
 Zone 1 – Zone 21 II 2G Ex h IIB T4 Gb e II 2D Ex h IIB T135°C Db X
 Zone M2 I M2 Ex h I Mb X*
 Ex h IIB T4 Gb e Ex h IIB T135°C Db

* The string relating to mining applications is not applicable to aluminium BOXER range pumps

BOXER PUMPS CODES ENCODING

ex. IMICR-P-HTTPV-
 Internal distributor, Boxer 35, body PP, air-side diaph. Hytrel®, product-side diaph. PTFE, AISI 316 L balls, PP ball seats, EPDM O-Ring.

IB07-	P	H	T	T	P	V	-	-
PUMP MODEL	PUMP BODY	AIR-SIDE DIAPHRAGM	FLUID-SIDE DIAPHRAGM	BALLS	BALL SEATS	O-RING	MANIFOLD	VERSION
IB07 - Boxer 07 IB15 - Boxer 15 IMICR - Microboxer IB35 - Boxer 35 IB50 - Boxer 50 IMIN - Miniboxer IB81 - Boxer 81 IB90 - Boxer 90 IB100 - Boxer 100 IB150 - Boxer 150 IB251 - Boxer 251 IB252 - Boxer 252 IB522 - Boxer 522 IB502 - Boxer 502 IB503 - Boxer 503	P - PP PC - PP+CF FC - PVDF+CF A - AISI 316 (L) AL - ALU	N - NBR D - EPDM H - Hytrel® M - Santoprene®	T - PTFE	T - PTFE A - AISI 316 L D - EPDM N - NBR	P - Polypropylene F - PVDF A - AISI 316 L I - PE-UHMW R - PPS L - Aluminium	D - EPDM V - Viton® N - NBR T - PTFE	X* 3* Y* W* K*	C* Z*

Example table, for the table with the complete codes please contact the Debem sales department.



*X = split manifold
 *3 = 3rd hole on the manifold
 *Y = manifold with NPT fitting
 *W = clamp manifold
 *K = manifold with reinforcement rings
 (all on request only)

C = CONDUCT version for ATEX ZONE 1
 Z = Version for IECEx Standard



Self priming



Under head



Drum Transfer



Split Suction and Delivery

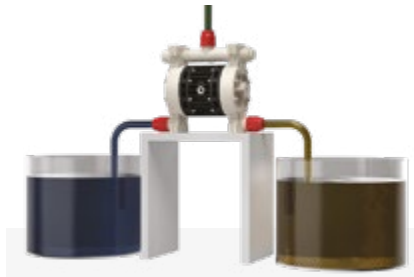

Split Suction