



DRUM & CONTAINER
PUMPS



DRUM & CONTAINER PUMPS

OPERATION & SERVICE GUIDE



Read and understand operation and service guide before commissioning.

● GENERAL INFORMATION / UPON RECEIVING



Read and understand operation and service guide before commissioning.

■ GENERAL INFORMATION

1. Check chemical chart to match the suitable material of the pump to the liquid you wish to pump. When selecting a pump, please take into account of criteria such as capacity, head, temperature, viscosity, liquid, solid size and chemical resistance before ordering.
2. Check power, voltage, fitting conditions, electrical connections and working conditions before commissioning.
3. Hose barbs are standard size 1" (25.4mm) or special size 3/4" (22mm).

■ UPON RECEIVING

1. Please check if pump model on the name plate corresponds to your order.
2. Check motor and pump for any damages upon receiving.
3. Make sure motor and pump has been fully installed and all connections and pipes have been connected

● OPERATING INSTRUCTIONS

1. Make sure hand wheel and all connections are securely fastened.
2. The maximum particle size must not exceed 3 mm. Use strainer for size over 3mm.
3. Do not store pump in a humid and corrosive environment.
4. Handle motor and pump with care.
5. Use F.R.L. combination unit (Air Filter, Regulator and Lubricator) for HD-A series air motors.
6. Turn on the air or power only after pump and pipes are in place.
7. Always start the air from low to high to extend the life time of the pump.
8. Make sure the voltage is connected according to correct electrical specification.
9. Motor is equipped with overload protection switch to allow dry running.
10. Do not leave pump unattended during operation.
11. Drum Pump is suitable to handle fluids with viscosity up to 800 CPS and up to 1000 CPS with high pressure impeller . Use high viscosity screw pump or Air operated double-diaphragm pump for transferring high viscosity fluids.
12. If strange noise occurs, check if the suction hose is obstructed by particles and colliding with impeller.
13. For safety, please properly bond and ground when handling solvent or flammable fluids.
14. Make sure pump and motor is properly and securely fasten, or otherwise, could result in serious damage to the couplings.
15. Set the switch "OFF" position before installation of motor and pump.
16. Never submerge motor in liquid or splash motor with liquid.

● **SUGGESTED INSTALLATION**



For safety, please properly bond and ground when handling solvent or flammable fluids as a static electric discharge could result in fire, explosion, injury or death. Do not start the pump in case of any doubt, and contact with local distributor.

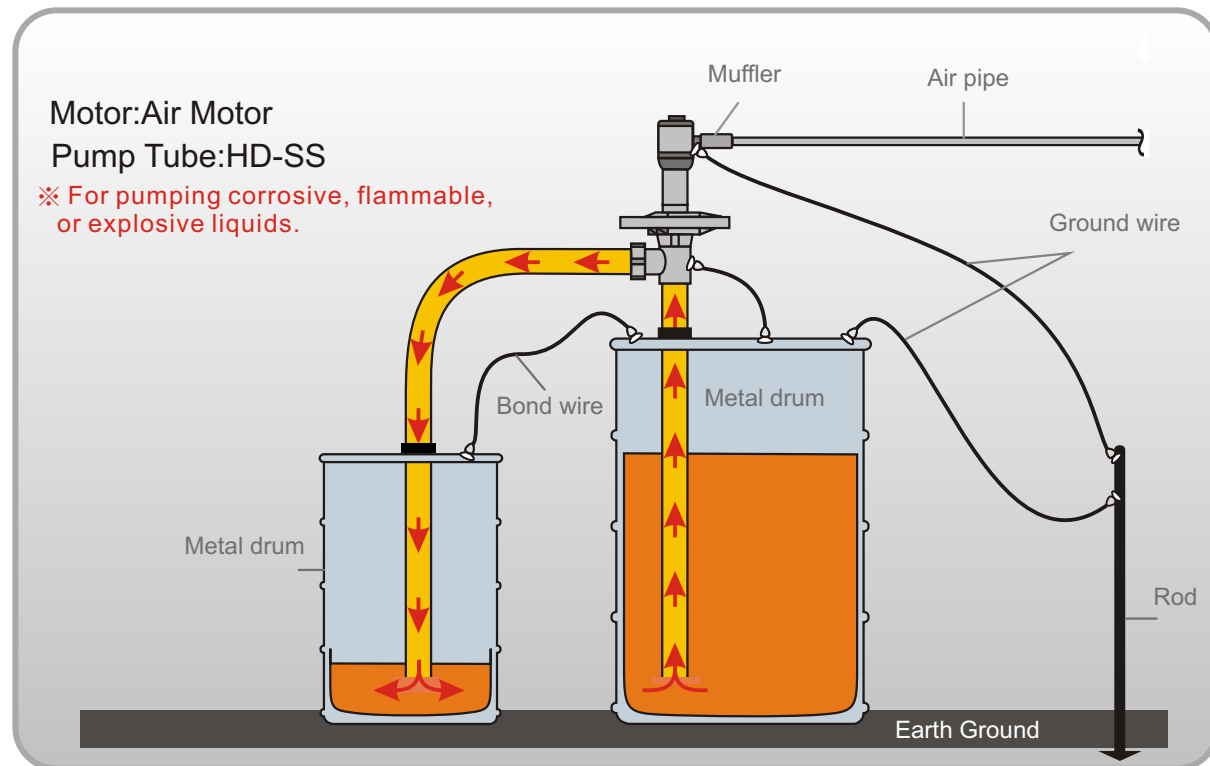
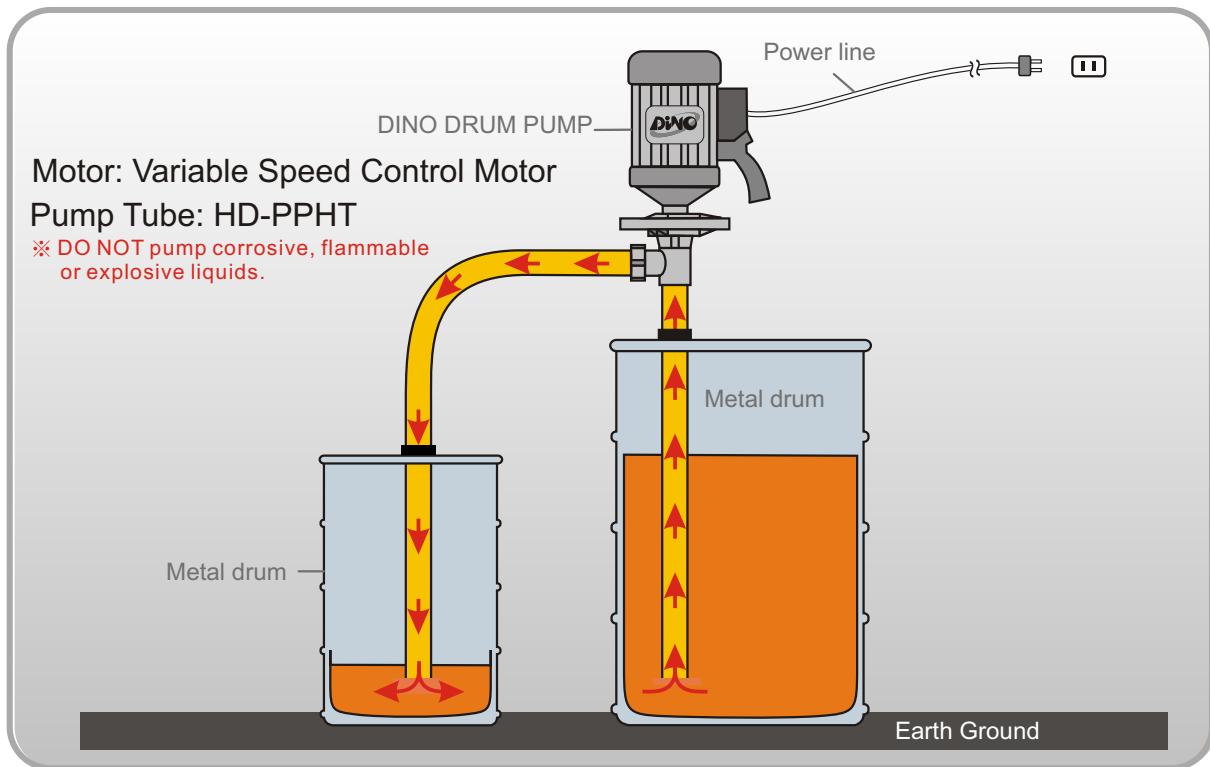

● COMMON APPLICATIONS

■ DINO INDUSTRIES SERVED

Automotive Industry, Chemical Industry, Electronic Industry, Food, Beverages, Waste Water Treatment, Semi-Conductor, Refineries, Pharmaceutical Industry, Agriculture, Cosmetics, Construction Industry, Pulp/Paper Industry, Mining, Ship Industry, Textile Industry, Paint and Coating, Plating, LCD Industry....

■ APPLICATIONS

Container Type	Model	Length
5GAL Bottles	HD-material 700	700mm (27")
55GAL Drums (200L)	HD-material 1000	1000mm (39")
Barrels & Tanks	HD-material 1200	1200mm (47")
IBC'S	HD-material 1500	1500mm (60")
Large Storage Vessels	HD-material 1800	1800mm (72")

■ COMMON APPLICATIONS

Material	Max. Temp	Common Applications
PPHT (Polypropylene)	80°C / 175°F	<ul style="list-style-type: none"> • Acetic Acid • Sulfuric Acid • Hydrochloric - 20% • Nitric Acid - 20% • Alkalies • Ferric Chloride
PVDF	130°C / 266°F	<ul style="list-style-type: none"> • Concentrated Nitric Acid • Sulfuric Acid-66 Baume • Sodium Hypochlorite • Propionic Acid • Stearic Acid • Hydrofluoric Acid
SS	100°C / 212°F	<ul style="list-style-type: none"> • Alcohol • Gasoline • Aqueous Ammonia • Isopropyl Ether • Solvents • Petroleum Products



For safety, please properly bond and ground when handling solvent or flammable fluids.

● MODEL NUMBER KEY

■ MODEL NUMBER KEY

Example: HD-SS1000 (high volume / material : SS316)
HD-SS1000-HV (high viscosity / material : SS316)

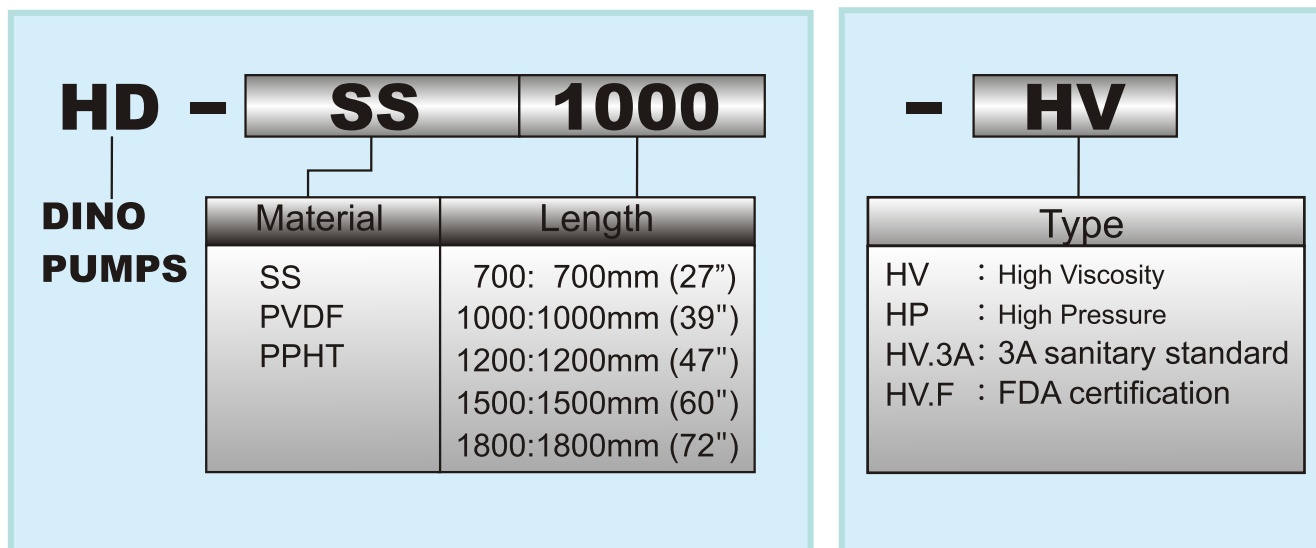

■ HD Variable Speed Control Motor

Model	Voltage	Horse power	Hertz	Watt
HD-E1-V	1 ϕ 110 V	1 HP	50-60 Hz	800 w
HD-E2-V	1 ϕ 220 V	1 HP	50-60 Hz	800 w



Contact your nearest representative or agent in case of any doubt.

● HD-PPHT series

HD - PPHT Series

Model	Length	Material	Shaft	Impeller
HD-PPHT700	700mm(27")	Polypropylene	Hastelloy	High Volume
HD-PPHT1000	1000mm(39")			
HD-PPHT1200	1200mm(47")			
HD-PPHT1500	1500mm(60")			
HD-PPHT1800	1800mm(72")			
HD-PPHT700-HP	700mm(27")	Polypropylene	Hastelloy	High Pressure
HD-PPHT1000-HP	1000mm(39")			
HD-PPHT1200-HP	1200mm(47")			
HD-PPHT1500-HP	1500mm(60")			
HD-PPHT1800-HP	1800mm(72")			

◎Max Temp : 175°F/80°C

◎Viscosity : 1000 Cps/mPas (HD-E)

700 Cps/mPas (HD-A1)

1200 Cps/mPas (HD-A3)

◎Max Specific Gravity : 1.8

◎Discharge Options : 1" (25mm) barb

3/4" (22mm) barb

◎Weight : 1-2kg

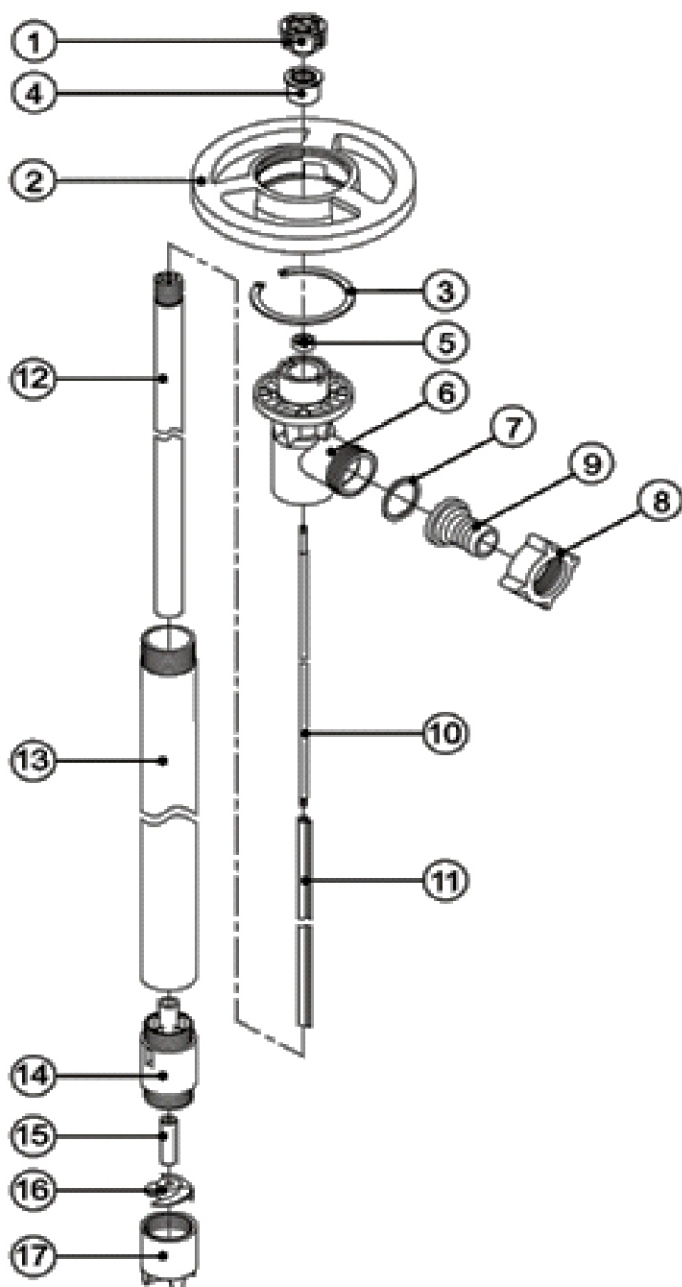

ITEM NO	DESCRIPTION	PART NUMBER
1	Pump coupling	610.804
2	Hand wheel	618.842
3	Snap ring	615.808
4	Bearing unit assembled - 2 pcs bearings, spacer x1, 2 pcs snap ring, bearing can x1	610.838
5	V-seal - Viton	640.800
6	Discharge housing (PP)	660.828
7	O-Ring (PTFE)	621.895
8	Wing nut	661.806
9	Hose barb (PP)	3/4" (22 mm) 660.851 1" (25 mm) 660.882
10	Drive shaft (Hastelloy)	370mm 615.841 700mm (27") 615.843 1000mm (39") 615.844 1200mm (47") 615.845 1500mm (60") 615.846 1800mm (72") 615.847
11	Guide sleeve (PTFE)	700mm(27") 615.814 1000mm(39") 615.815 1200mm(47") 615.816 1500mm (60") 615.817 1800mm(72") 615.818
12	Inner tube (PP)	700mm (27") 666.800 1000mm (39") 666.801 1200mm (47") 666.802 1500mm (60") 666.815 1800mm (72") 666.816
13	Outer tube (PP)	700mm (27") 666.804 1000mm (39") 666.803 1200mm (47") 666.805 1500mm (60") 666.817 1800mm (72") 666.818
14	Pump housing	665.824
15	Shaft bushing (PTFE)	616.806
	Shaft bushing (Rulon)	616.806-R
16	Impeller (PVDF)	646.808
	High pressure impeller	646.808HH
17	Pump foot	666.809
	High pressure pump foot	666.809HH

● **HD-SS series**

● **HD - SS Series**

Model	Length	Material	Shaft	Impeller
HD-SS700	700mm(27")	SUS 316	Stainless 316	High Volume
HD-SS1000	1000mm(39")			
HD-SS1200	1200mm(47")			
HD-SS1500	1500mm(60")			
HD-SS1800	1800mm(72")			
HD-SS700-HP	700mm(27")	SUS 316	Stainless 316	High Pressure
HD-SS1000-HP	1000mm(39")			
HD-SS1200-HP	1200mm(47")			
HD-SS1500-HP	1500mm(60")			
HD-SS1800-HP	1800mm(72")			

◎Max Temp : 212°F/100°C

◎Viscosity : 1000 Cps/mPas (HD-E)
700 Cps/mPas (HD-A1)
1200 Cps/mPas (HD-A3)

◎Max Specific Gravity : 1.8

◎Discharge Options : 1" (25mm) barb
3/4" (22mm) barb

◎Weight : 8-12kg

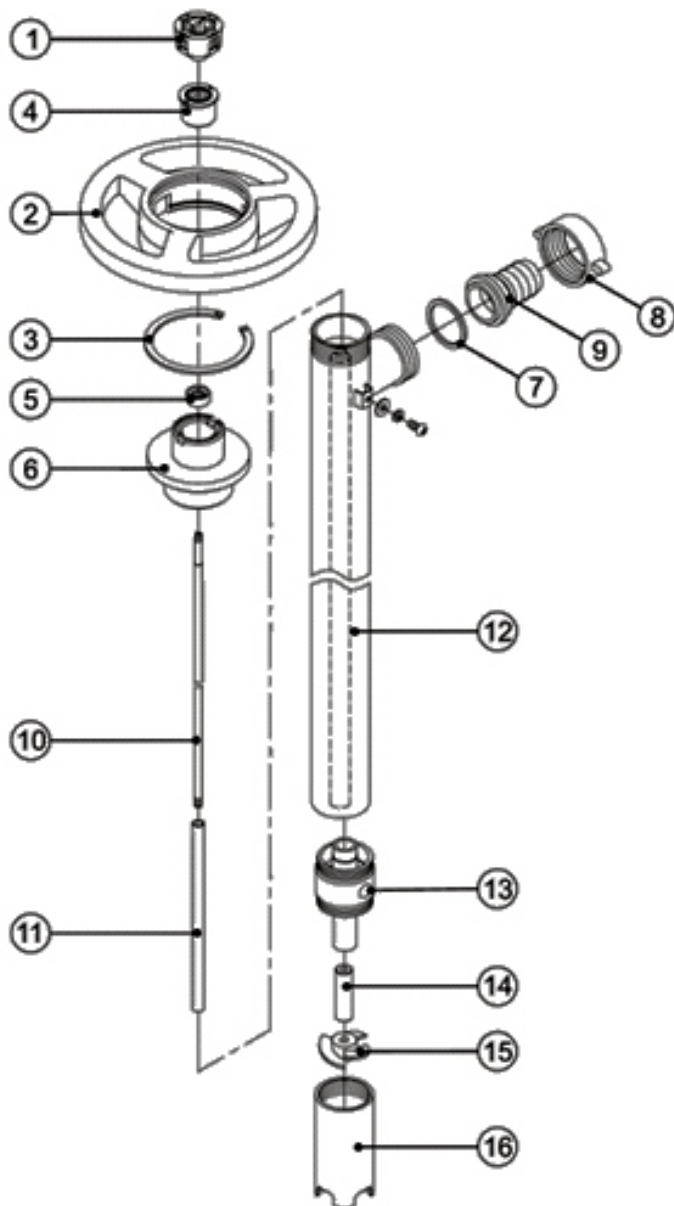

ITEM NO.	DESCRIPTION	PART NUMBER
1	Pump coupling	610.804
2	Hand wheel	618.842
3	Snap ring	615.808
4	Bearing unit assembled - bearing x 2, spacer x1, snap ring x2, bearing can x 1	610.838
5	V-Seal - VT	640.800
6	Connection flange (SUS304)	620.800
7	O-ring (PTFE)	621.895
8	Wing nut (SUS304)	620.868
9	Hose barb, 1" (25 mm)	621.896
10	Drive shaft	700mm (27") 620.827 1000mm (39") 620.828 1200mm (47") 620.829 1500mm (60") 627.809 1800mm (72") 627.810
11	Guide sleeve (PTFE)	700mm (27") 620.831 1000mm (39") 627.815 1200mm (47") 820.832 1500mm (60") 827.811 1800mm (72") 627.812
12	Inner/outer tube assembly (SUS316)	700mm (27") 627.800 1000mm (39") 627.801 1200mm (47") 627.802 1500mm (60") 627.813 1800mm (72") 827.814
13	Pump housing	627.804
14	Shaft bushing (PTFE) Shaft busing (Rulon)	616.806 616.806-R
15	Impeller (PVDF)	627.806
16	Pump foot	627.808
	High pressure pump foot	627.808HH

● **HD-PVDF series**

● **HD - PVDF Series**

Model	Length	Material	Shaft	Impeller
HD-PVDF700	700mm(27")	PVDF	Hastelloy	High Volume
HD-PVDF1000	1000mm(39")			
HD-PVDF1200	1200mm(47")			
HD-PVDF1500	1500mm(60")			
HD-PVDF1800	1800mm(72")			
HD-PVDF700-HP	700mm(27")	PVDF	Hastelloy	High Pressure
HD-PVDF1000-HP	1000mm(39")			
HD-PVDF1200-HP	1200mm(47")			
HD-PVDF1500-HP	1500mm(60")			
HD-PVDF1800-HP	1800mm(72")			

◎Max Temp : 266°F/130°C

◎Viscosity : 1000 Cps/mPas (HD-E)
700 Cps/mPas (HD-A1)
1200 Cps/mPas (HD-A3)

◎Max Specific Gravity : 1.8

◎Discharge Options : 1" (25mm) barb
3/4" (22mm) barb

◎Weight : 1-3kg

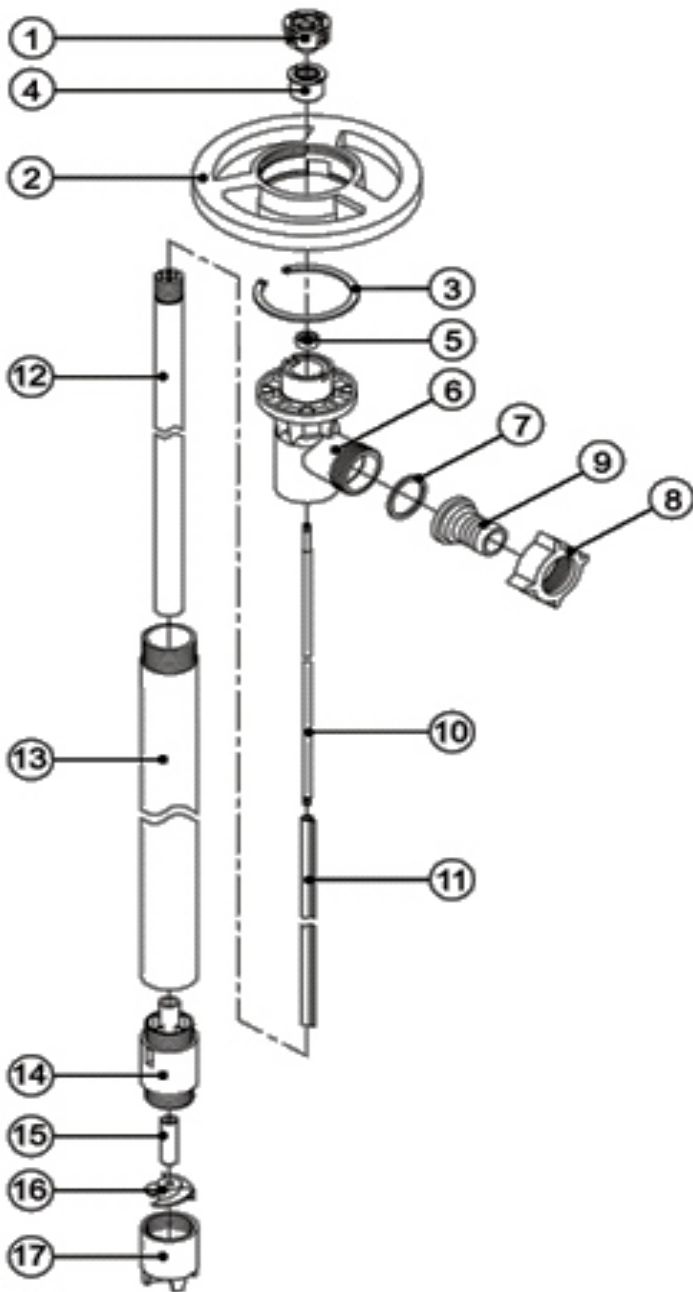

ITEM NO	DESCRIPTION	PART NUMBER
1	Pump coupling	610.804
2	Hand wheel	618.842
3	Snap ring	615.808
4	Bearing unit assembled - bearing x 2, spacer x1, snap ring x 2, bearing can x1	610.838
5	V-seal - VT	640.800
6	Discharge housing (PVDF)	640.728
7	O-RING (PTFE)	621.895
8	Wing nut (PVDF)	641.706
9	Hose barb, 3/4" (22 mm)	640.751
	1" (25 mm)	640.882
10	Drive shaft (Hastelloy)	370mm 615.841 700mm (27") 615.843 1000mm (39") 615.844 1200mm (47") 615.845 1500mm (60") 615.846 1800mm (72") 615.847
11	Guide sleeve (PTFE)	700mm(27") 615.814 1000mm(39") 615.815 1200mm(47") 615.816 1500mm (60") 615.817 1800mm(72") 615.818
12	Inner tube (PVDF)	700mm (27") 646.800 1000mm (39") 646.801 1200mm (47") 646.802 1500mm (60") 646.811 1800mm (72") 646.812
13	Outer tube (PVDF)	700mm (27") 646.804 1000mm (39") 646.803 1200mm (47") 646.805 1500mm (60") 646.813 1800mm (72") 646.814
14	Pump housing	646.807
15	Shaft bushing (PTFE)	616.806
	Shaft bushing (Rulon)	616.806-R
16	Impeller (PVDF)	646.808
17	Pump foot	646.809
	High pressure pump foot	646.809HH

● HD-HV High Viscosity Series

HD-HV High Viscosity Screw Pump Series

Model	Length	Material	Mech. Seal	Stator	Rotor
HD-SS700-HV	700mm(27")	SUS 304 SUS 316	SIC	PTFE	SUS316
HD-SS1000-HV	1000mm(39")				
HD-SS1200-HV	1200mm(47")				

◎Max. Temp. : 120°C/248°F

◎Max. Pressure : 12bar/ 174psi

◎Max. Viscosity : 100,000 cps

◎ Outlet Options : 1.08" (27.5mm) barb

1.3" (33mm) barb

◎Weight : 9-12kg

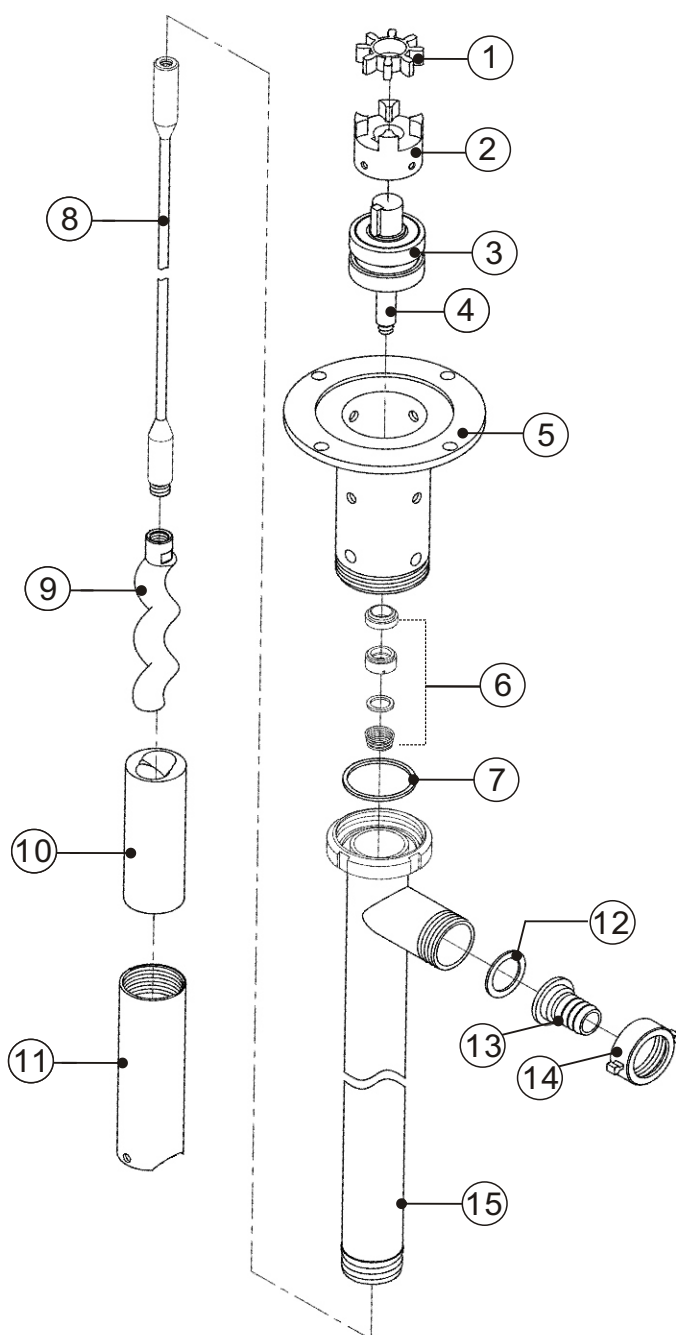

ITEM NO.	DESCRIPTION	PART NUMBER
1	Coupling Insert	607.845
2	Motor/ Pump Couping	607.840
3	Bearing set (bearing x2, spacer, clip)	607.855
4	Bearing Shaft	607.850
5	Bearing Housing (SUS304)	607.854
6	Mechanical Seal, SIC	607.803
7	Gasket PTFE	607.838
	Viton	607.839
8	Drive Shaft (SUS316)	
	700mm(27")	607.804
	1000mm(39")	607.805
	1200mm(47")	607.806
9	Rotor	
	50mm (SUS316)	607.809
10	Stator (PTFE) Size 50mm	607.820
11	Stator tube (SUS304/ SUS316)	607.875
12	O-Ring PTFE	607.830
13	Hose Barb 1.08"(27.5mm)	607.828
	1.3"(33mm)	607.829
14	Wing Nut (SUS304/ SUS316)	607.827
15	Outer Tube (SUS304/ SUS316)	
	700mm(27")	607.870
	1000mm(39")	607.871
	1200mm(47")	607.872

● HD-E Motor

HD - E Variable Speed Control Motor Series

Model	Power
HD-E1-V	110 V / 1 ϕ / 1HP / 50-60Hz / 800w
HD-E2-V	220 V / 1 ϕ / 1HP / 50-60Hz / 800w

©Weight : 3.5 KG



Do not pump flammable or explosive fluids.

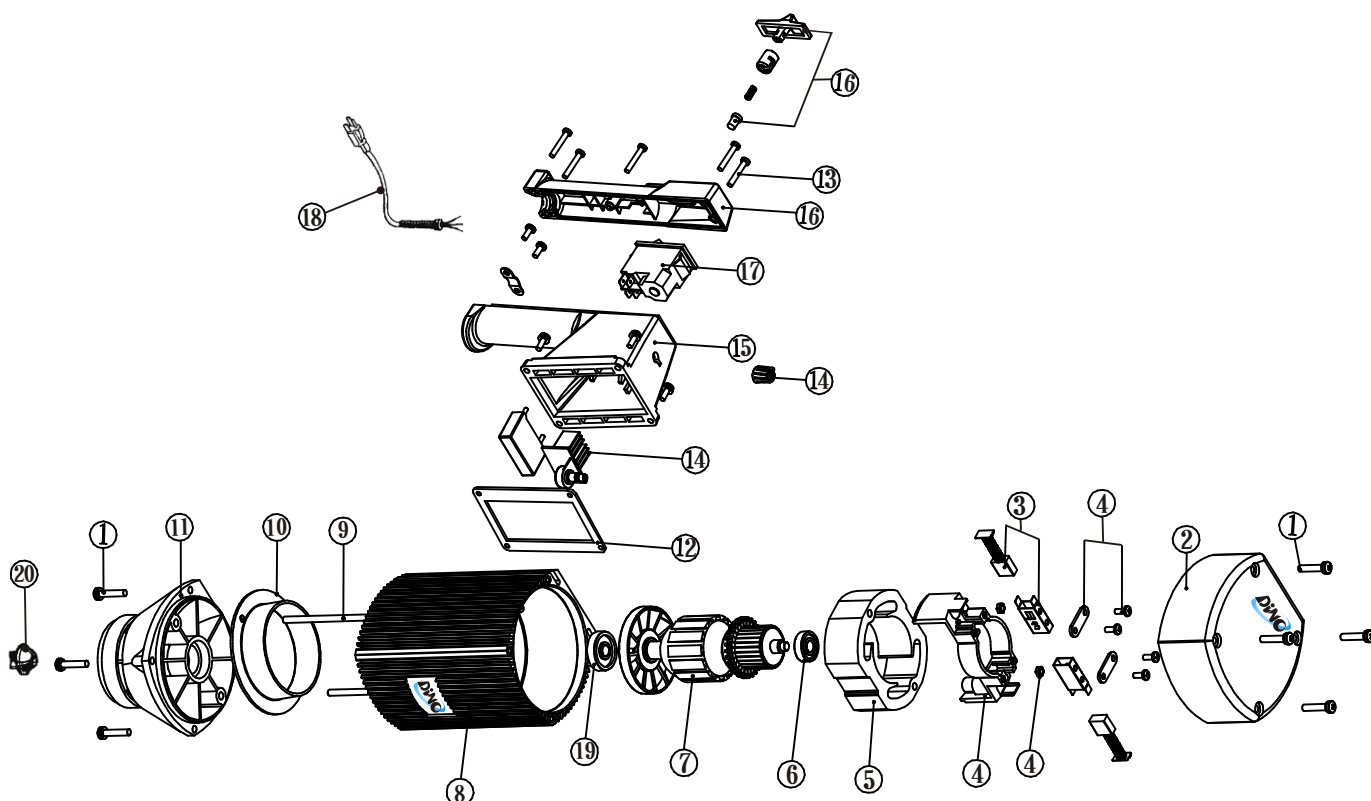

ITEM NO.	DESCRIPTION	PART NUMBER	ITEM NO.	DESCRIPTION	PART NUMBER
1	Screw for plastic housing (8 required)	681.830	12	Gasket	681.867
2	Motor cover	680.800	13	Screw (5 required)	682.820
3	Carbon brush 110V/220V	685.809	14	Variable speed controller includes knob	
4	Brush holder	685.808		110V	680.804
5	Stator 110V	685.803		220V	680.805
	220V	687.802	15	Switch housing	680.801
6	Ball bearing	683.831	16	Switch cover with pull rod	680.802
7	Armature 110V	685.802	17	Overload switch	
	220V	687.801		110V	686.811
8	Motor housing, plastic	685.810		220V	687.804
9	Rod connector	685.806	18	Power cord w/strain relief & plug	683.860
10	Guide disc	685.804	19	Ball bearing	681.826
11	Lower housing	681.800	20	Motor coupling	683.833

● HD-A AIR MOTOR

■ HD-A1 Air Motor

Casing : Aluminum (Chromium)	Max. Viscosity : 700cps
Max. Inlet air pressure : 87psi (6bar)	RPM : 15,000 (5bar air pressure)
Air consumption : 0.55Nm ³ /min@6kg/cm ²	RPM : 18,000 (6bar air pressure)
Joint (air) : 1/4"	Horsepower : 420w (0.56 HP)
Accessory : muffler \ air regulator	Weight : 1kg

⚠ Please install lubricator \ air filter and air regulator (F \ R \ L combination).

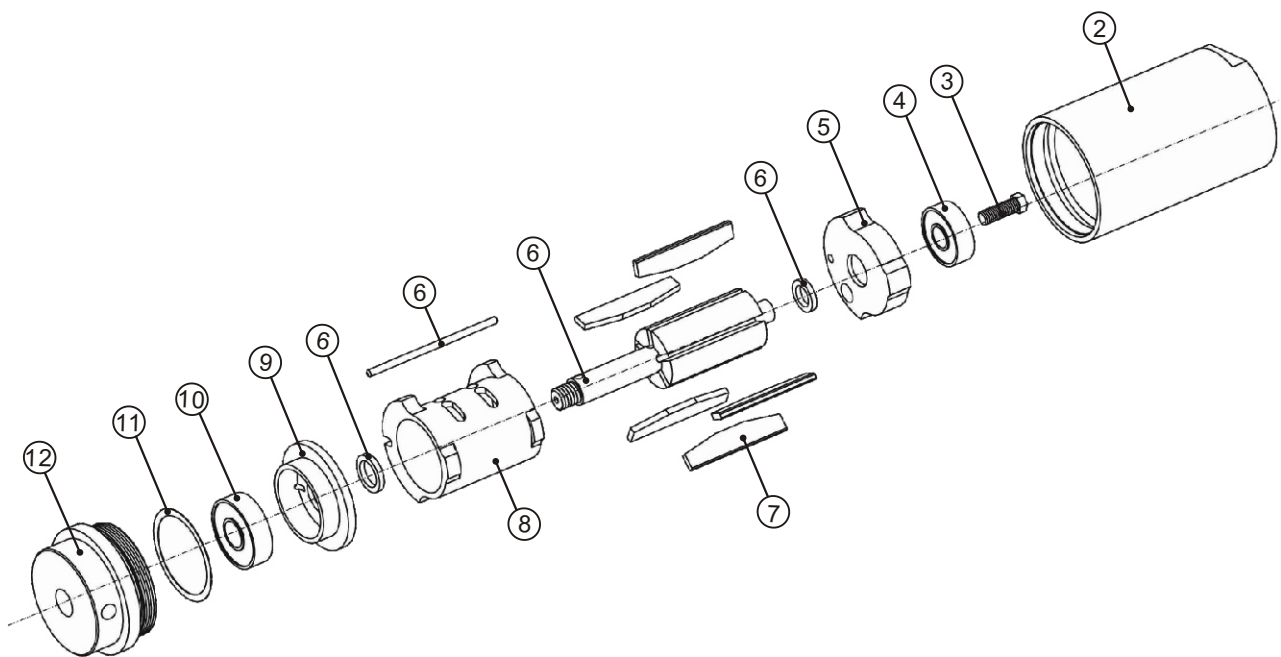

ITEM NO.	DESCRIPTION	PART NUMBER
2	Housing	101.201
3	Screw	101.303
4	Ball Bearing	101.401
5	Front plate	101.501
6	Rotor set	101.601
7	Blade	101.701
8	Cylinder	101.801
9	End plate	101.901
10	Ball Bearing	101.110
11	Gasket	101.210
12	Cap	101.120

● HD-A AIR MOTOR SERIES

■ HD-A2 Oil Free Air Motor

Casing : Aluminum (EPOXY)	RPM : 15,000 (5bar Air pressure)
Max. Inlet air pressure : 87psi (6bar)	RPM : 18,000 (6bar Air pressure)
Air consumption : 0.55Nm ³ /min@6kg/cm ²	Horsepower : 560w (0.75 HP)
Joint (air) : 1/4"	Weight : 1.2kg
Max. viscosity : 1200cps	

! Please install the air filter for reduce moisture from the compressed air supply.

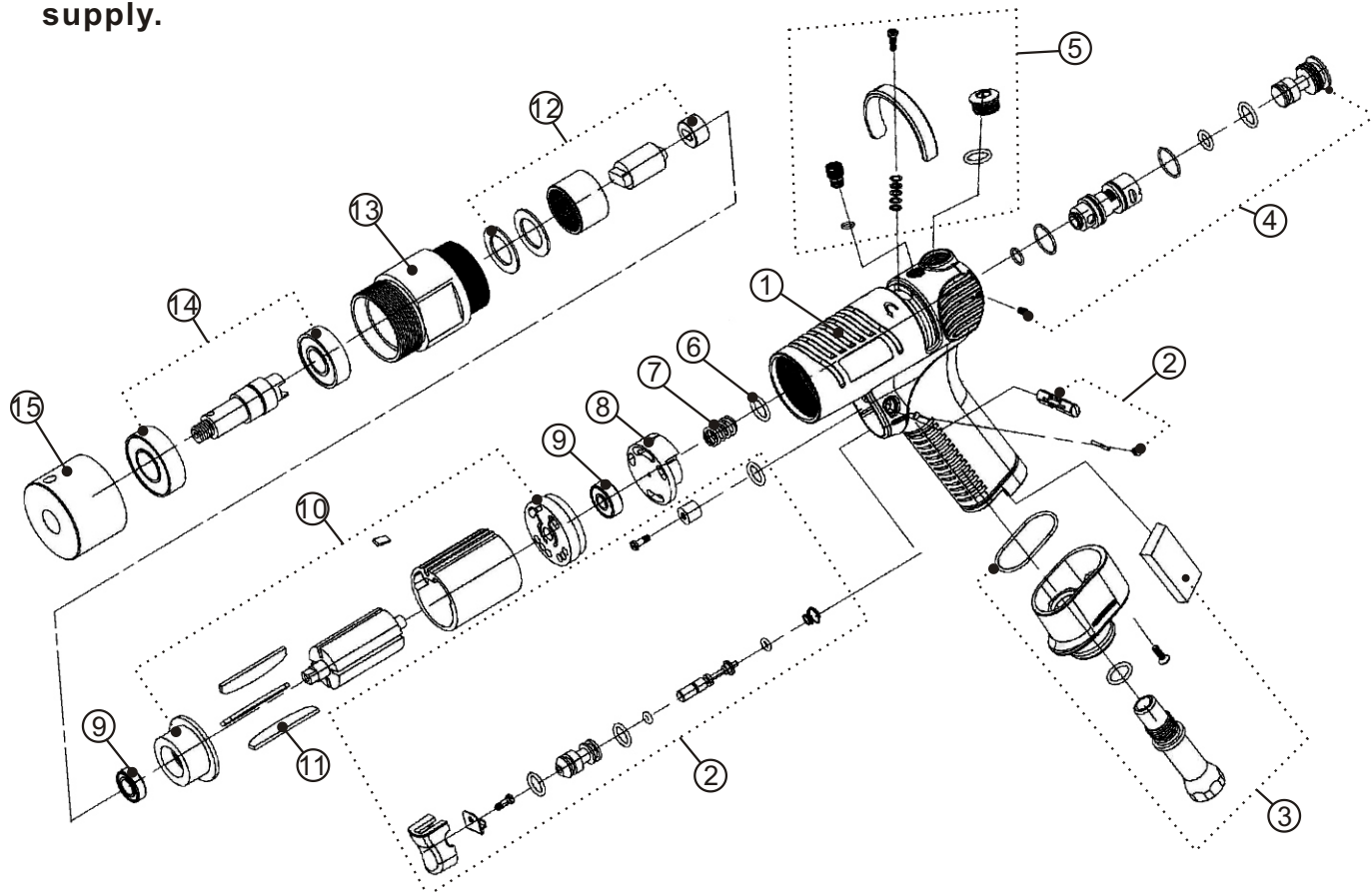

ITEM NO.	DESCRIPTION	PART NUMBER
1	Motor Housing	201.101
2	Trigger Assembly	202.216
3	Basket Assembly	203.306
4	Back Cap Set	204.406
5	Cover Set	205.507
6	O-ring	206.601
7	Spring	207.701
8	Valve	208.801
9	Ball Bearing (2 required)	209.902
10	Air Motor	210.105
11	Vane (3 required)	211.113
12	Drive Shaft Assembly	212.124
13	Drive Shaft Housing	213.131
14	Shaft Set	214.143
15	Housing	215.151

● HD-A AIR MOTOR SERIES

■ HD-A3 Air Motor

Casing : Stainless steel \ Aluminum	Max. viscosity : 1200cps
Max. Inlet air pressure : 100psi (7bar)	RPM : 8,500 (5bar Air pressure)
Air consumption : 30CFM@92psi	RPM :11,000 (7bar Air pressure)
Joint (air): 1/4"	Horsepower : 400w (0.55HP)
Accessory : muffler \ air regulator	Weight : 1.8kg

⚠ Please install lubricator \ air filter and air regulator (F \ R \ L combination) .

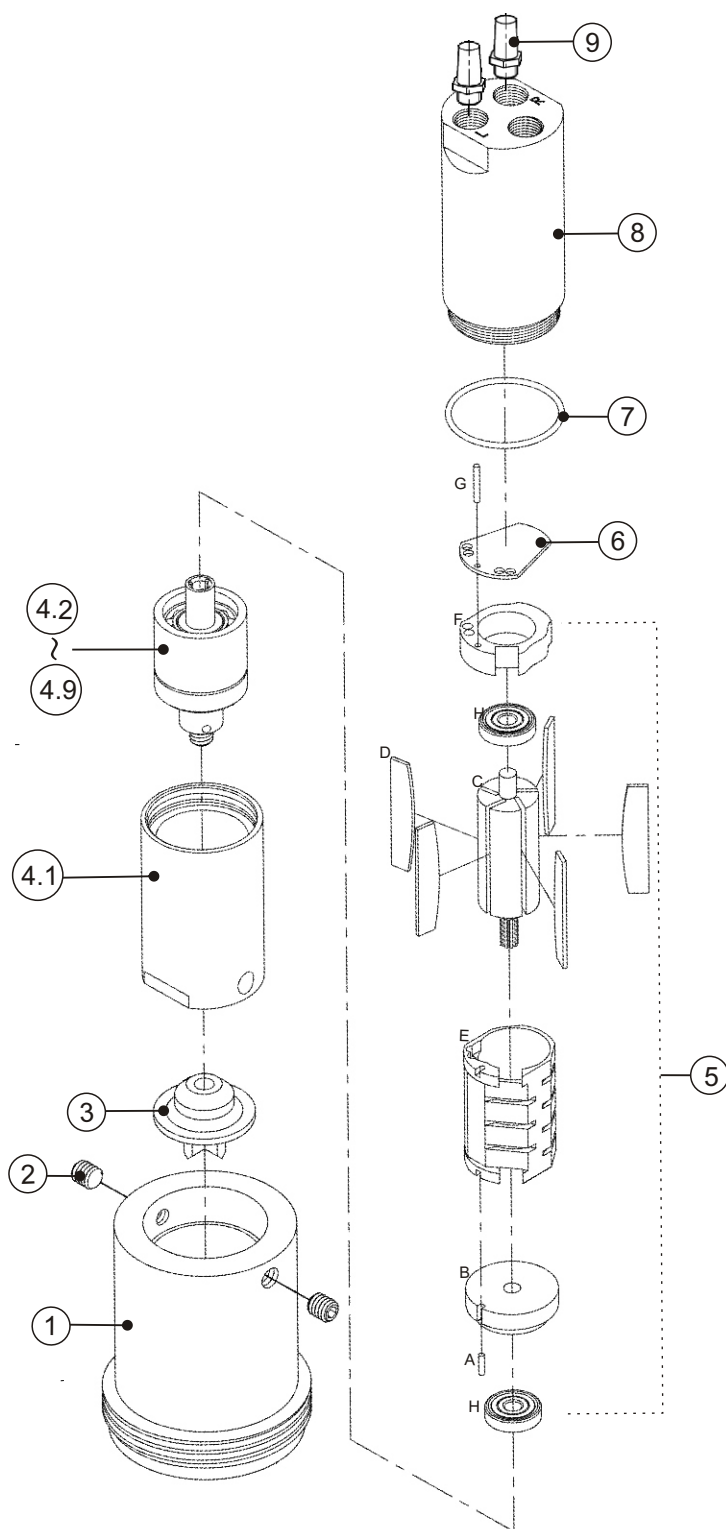

ITEM NO.	DESCRIPTION	PART NUMBER
1	Connection Piece	240.063
2	Threaded Pin	682.186
3	Coupling	683.833
※4	Gearing consisting of 4.1-4.9	644.282
4.1	Gear Housing	644.927
4.2	Seal Ring	280.861
4.3	Groove Ball Bearing	280.503
4.4	Spacer Sleeve	544.544
4.5	Spindel	644.028
4.7	Bearing needle (3 required)	280.133
4.8	Groove Ball Bearing	180.597
4.9	Sleeve	230.238
※5	Air motor M3 consisting of A-H	230.687
A	Bearing needle	280.934
B	Bearing Cover	434.186
C	Rotor	230.738
D	Vane (4 required)	632.395
E	Rotor Cylinder	632.298
F	Bearing Cover	632.096
G	Bearing needle	280.836
H	Groove Ball Bearing	280.400
6	Intermediate Plate	632.695
7	O-ring	280.752
8	Motor Housing	444.454
9	Sinter Cone (2 required)	280.367

● **TROUBLESHOOTING**

MALFUNCTION	POSSIBLE CAUSES	TROUBLESHOOTING
Motor fail to run	Overcurrent/ motor burned.	Check and repair or replace
	Power short circuit or plug falls out.	Check and reconnect
	Bearing unit abrasion.	Check and replace
	Stator worn due to erosion.	Check and replace
	Bad power connection.	Check and repair or replace
	Switch	Check and replace
	Unstable current, Motor overload.	Please install stabilizer or overload protector
Pump suddenly stop in operating	Motor overheated.	Turn off the power and restart in 20 minutes.
	Fluid too viscous.	check the viscosity for suitable pump.
	Pump clogged	check and remove blockage ; install or change strainer.
	Air motor became slowly or stop	check the air supplier
Pump rupture or deformed	Liquid temperature too high	check temperature with suitable material and replace
	Suction/ discharge line not properly stable and vibration	make the suction/ discharge stability or replace.
In normal operating, but the flow rate is small in pumping	Clogged	check and remove blockage ; install or change strainer.
	Impeller damage or abrasion	Check and replace
	Connection not security tighten or damaged	Check and repair or replace
	Liquid should higher than pump foot 2cm	Check and replace drum
Excessive noise or vibration	Connections not security tighten.	Check and repair
	Motor/ pump coupling abrasion or damage	Check and replace
	Bearing unit abrasion	Replace
	Shaft or guide sleeve abrasion	Replace
	Suction/ discharge line not properly stable and vibration	Make the suction/ discharge stability or replace.
	Shaft bushing abrasion	Replace
Fluid leaking	Connections not security tighten.	Check and repair
	Discharge leaking	check discharge O-ring and replace
	Oil seal, shaft, bearing unit abrasion	Replace



※ Turn off the power and air supply immediately and contact info@dinopumps.com or your local representative if you still have problems.