

Electrical Characteristics										
Frequency	Hz	50				60				
Voltage (series star)	V	380	400	415	440	415	440	460	480	
Rated power class H	kVA	250	250	250	230	290	300	300	300	
	kW	200	200	200	184	232	240	240	240	
Rated power class F	kVA	230	230	230	215	270	280	280	280	
	kW	184	184	184	172	216	224	224	224	
Regulation with DSR		±1 % with any power factor and speed variations between -5% +30%								
Insulation class		H								
Execution		Brushless								
Stator winding		12 ends								
Rotor		with damping cage								
Efficiencies class H	4/4	%	93,3	93,4	93,1	92,9	93,8	94,3	94,4	94,5
(see graph. for details)	3/4	%	93,4	93,7	93,6	93,3	94,3	94,5	94,7	94,9
	2/4	%	92,3	92,4	92,4	92,2	93,4	93,5	93,6	93,7
	1/4	%	90,1	89,9	89,7	89,5	90,6	90,6	90,6	90,4
Reactances (f. l.cl. F)	Xd	%	229,4	207	192,3	157,4	267,7	246,3	225,4	207
	Xd'	%	15,5	14,0	13,0	10,6	18,1	16,7	15,2	14,0
	Xd''	%	8,0	7,2	6,7	5,5	9,3	8,6	7,8	7,2
	Xq	%	129,6	117	108,7	89,0	151,3	139,2	127,4	117
	Xq'	%	129,6	117	108,7	89,0	151,3	139,2	127,4	117
	Xq''	%	24,4	22	20,4	16,7	28,5	26,2	24,0	22
	X ₂	%	17,7	16,0	14,9	12,2	20,7	19,0	17,4	16,0
	X ₀	%	2,7	2,4	2,2	1,8	3,1	2,9	2,6	2,4
Short Circuit Ratio	Kcc		0,41	0,44	0,68	1,11	0,32	0,38	0,41	0,44
Time Constants	Td'	sec.	0,085							
	Td''	sec.	0,013							
	Tdo'	sec.	1,30							
	Tα	sec.	0,017							
Short Circuit Current Capacity		%	>300				>350			
Excitation at no load	Amp.		0,6	0,71	0,8	0,95	0,4	0,5	0,58	0,7
Excitation at full load	Amp.		2,7	2,8	3	3,2	2,4	2,6	2,7	2,8
Overload (long-term)		%	1 hour in a 6 hours period 110% rated load							
Overload per 20 sec.		%	300							
Stator Winding Resistance (20 °C)		Ω	0,0065							
Rotor Winding Resistance (20 °C)		Ω	4,887							
Exciter Resistance (20 °C)		Ω	Rotor : 0,685				Stator : 15,28			
Heat dissipation at f.l.cl.H	W		14362	14133	14823	14062	15335	14507	14237	13968
Telephone Interference			THF < 2%				TIF < 40			
Radio interference			EN61000-6-3, EN61000-6-2. For others standards apply to factory							
Waveform Distors.(THD) at f. load	LL/LN %		2 / 2,1							
Waveform Distors.(THD) at no load	LL/LN %		2,9 / 3,1							
Mechanical characteristics										
Protection			IP 21 (other protection on request)							
DE bearing			6318.2RS							
NDE bearing			6314.2RS							
Weight of wound stator assembly	kg		231							
Weight of wound rotor assembly	kg		147,5							
Weight of complete generator	kg		680							
Maximun overspeed	rpm		2250							
Unbalanced magnetic pull at f.l.cl.F	kN/mm		5,1							
Cooling air requirement	m ³ /min		32				39			
Inertia Constant (H)	sec.		0,116				0,139			
Noise level at 1m/7m	dB(A)		82 / 69				86 / 73			

All technical data are to be considered as a reference and they can be modified without any notice

This document is a propriety of Mecc Alte S.p.a..All rights reserved.

50 Hz

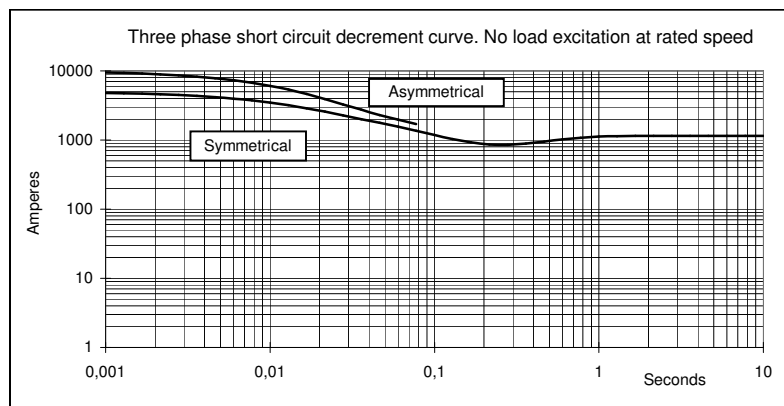
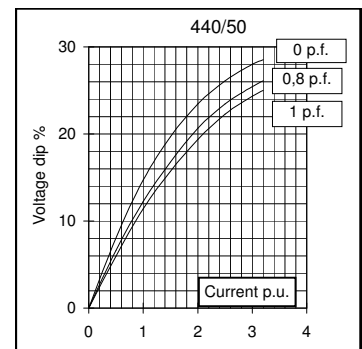
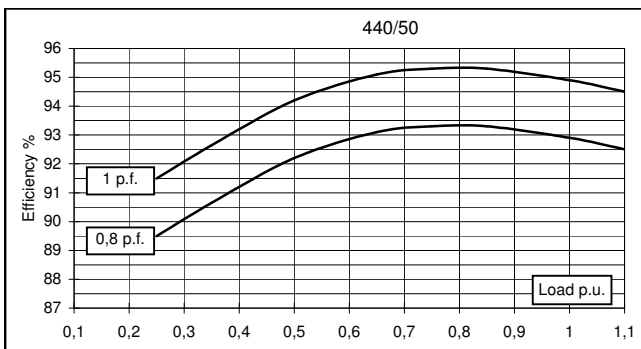
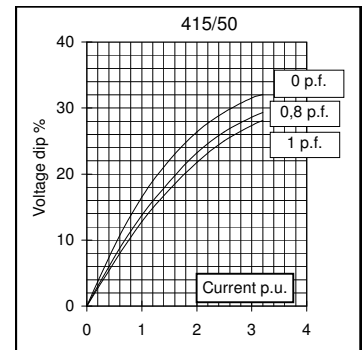
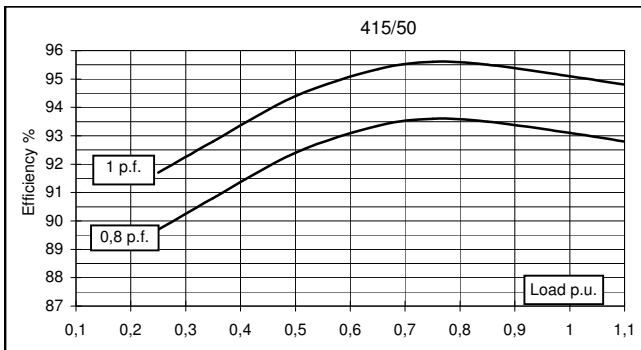
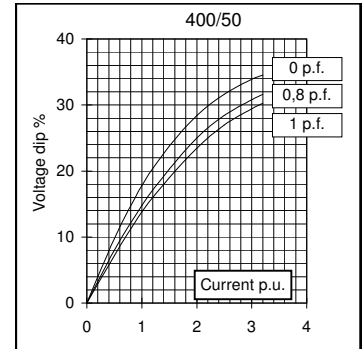
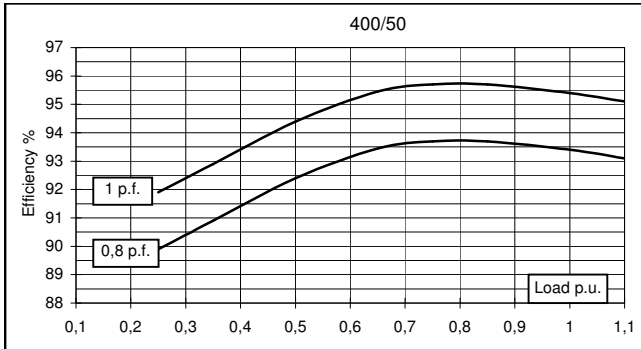
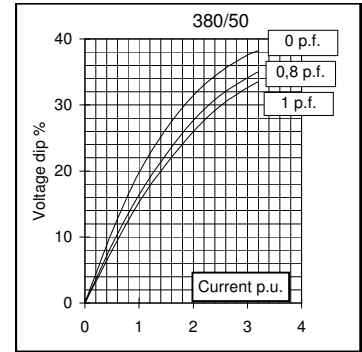
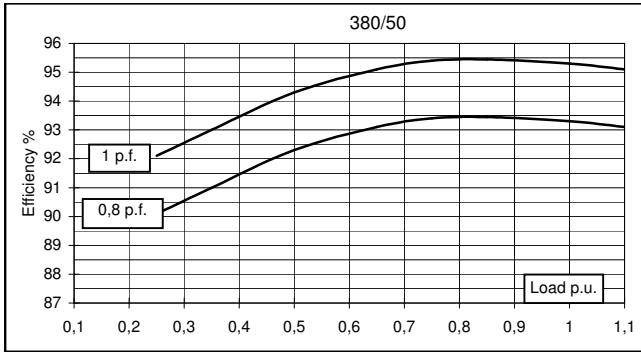

This document is a propriety of Mecc Alte S.p.a.. All rights reserved.

60 Hz

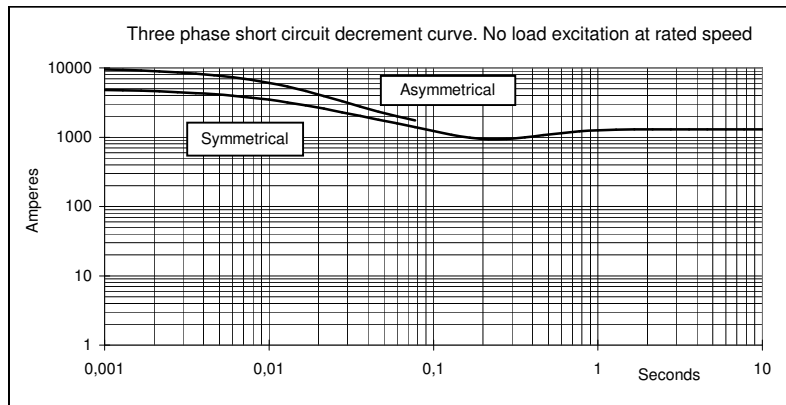
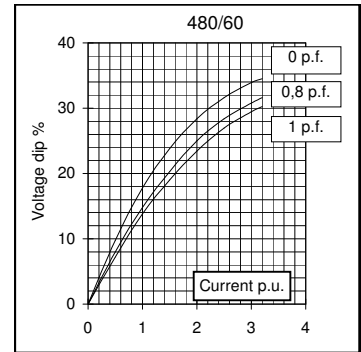
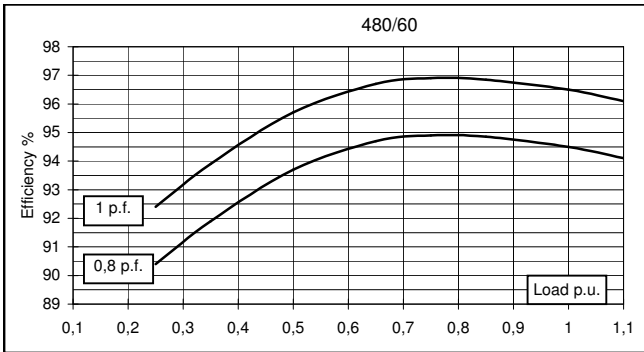
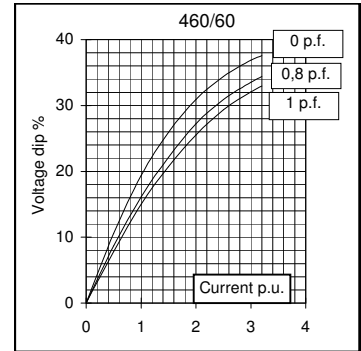
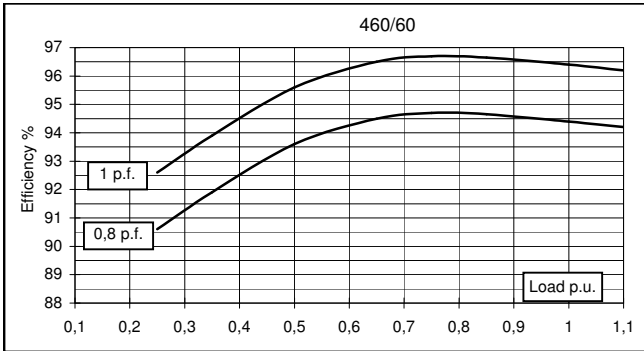
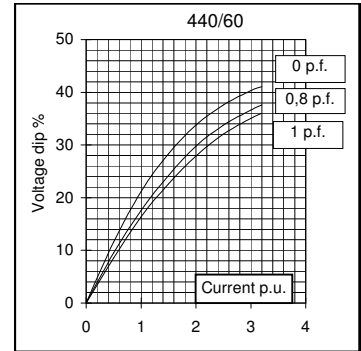
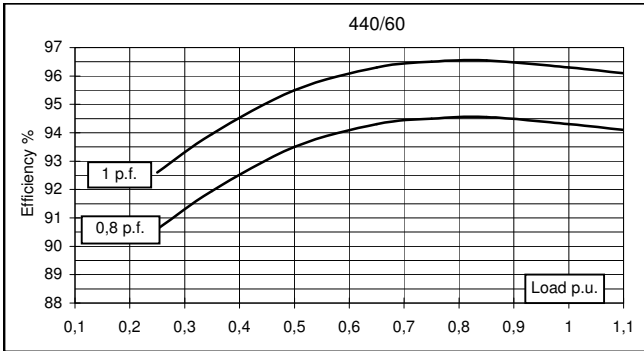
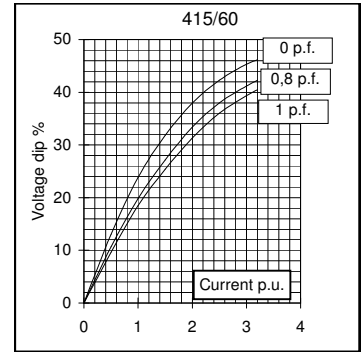
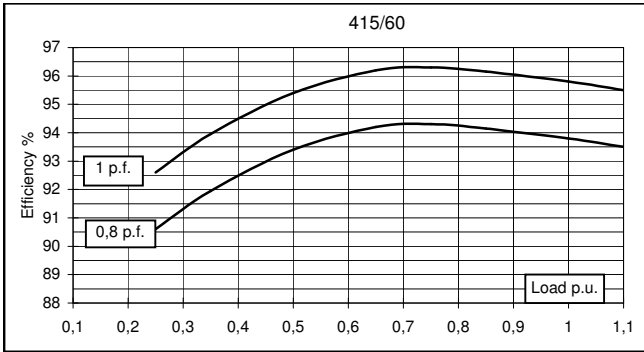

This document is a propriety of Mecc Alte S.p.a.. All rights reserved.

TWO BEARING MOMENTS OF INERTIA

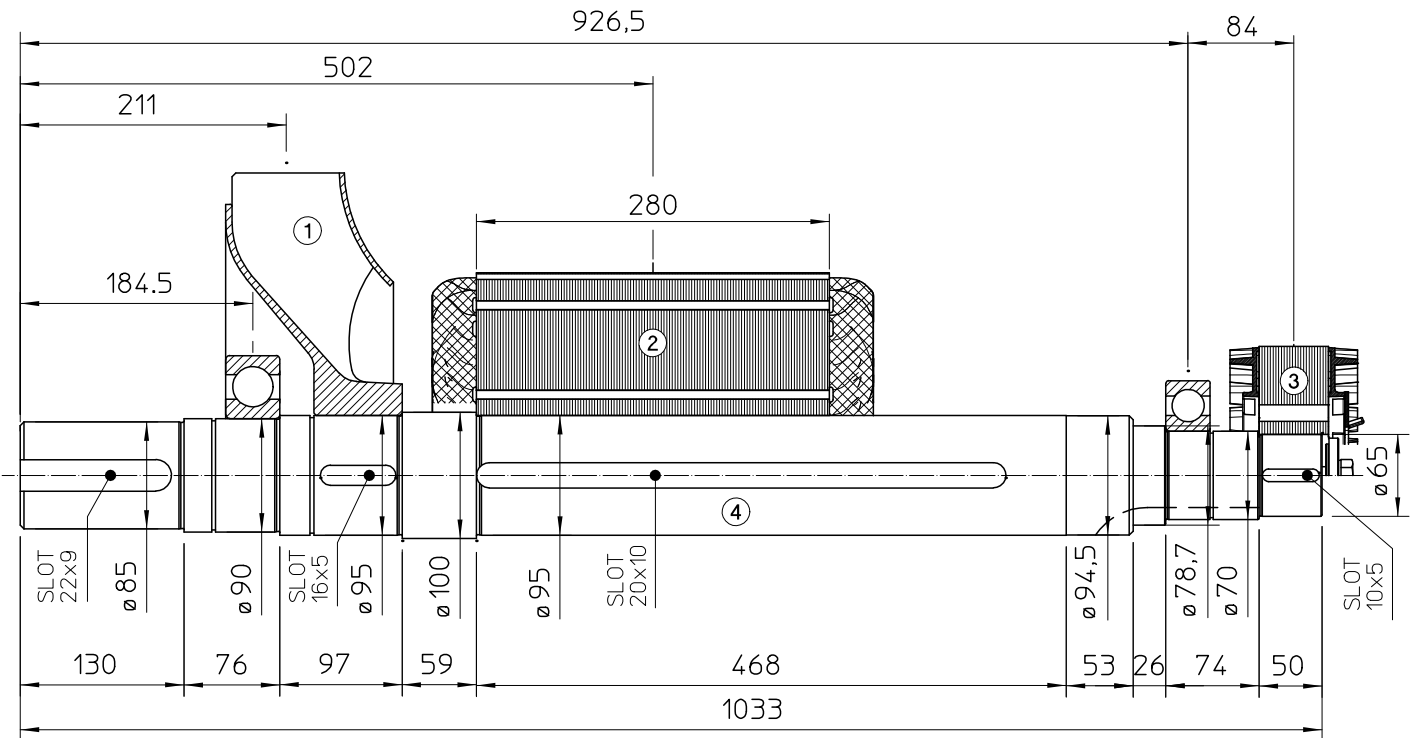

POS.	COMPONENT	WEIGHT (kg)	J (kgm ²)
1	FAN	6.1	0.1887
2	MAIN ROTOR	147.5	2.0195
3	EX. ROTOR	14.5	0.0874
4	SHAFT	49.9	0.0525
TOTAL		218	2.3481

FAMCO
 هایپرمنت

FAMCO
 هایپرمنت

TWO BEARING DIMENSIONS

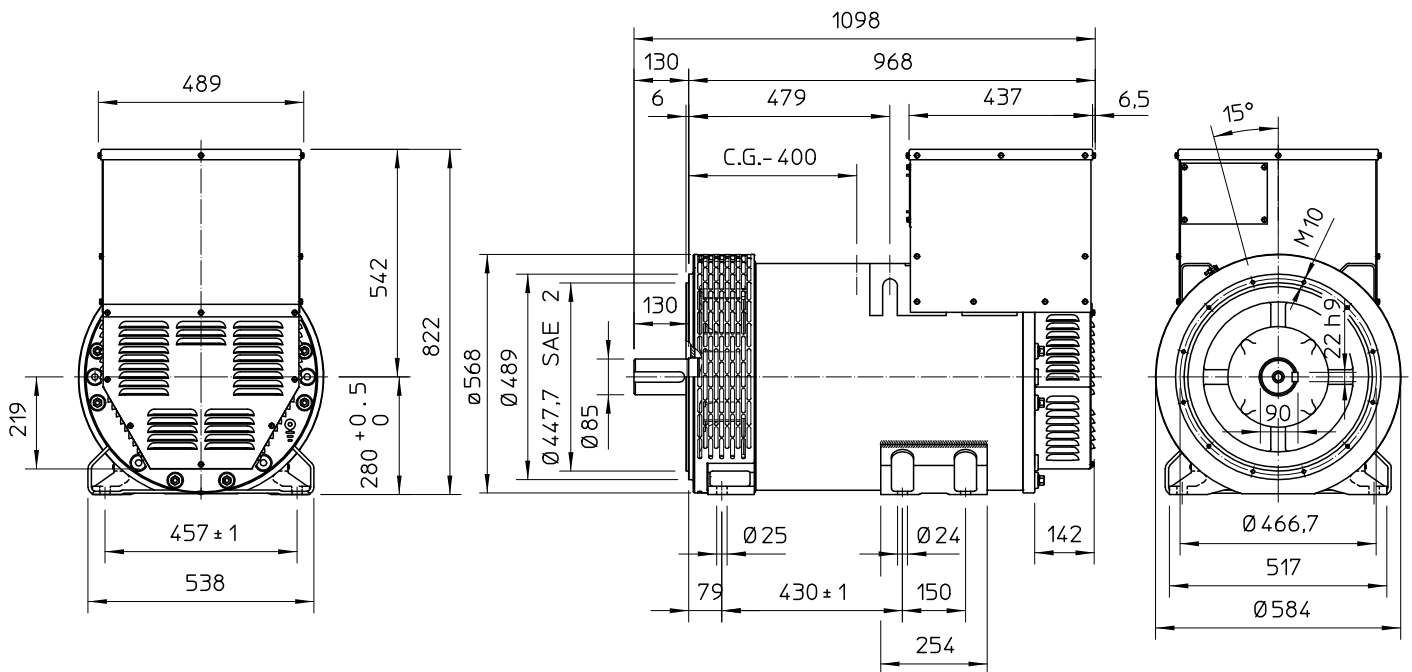

C.G.= GRAVITY CENTER

FAMCO
 هایپر صنعت

SINGLE BEARING MOMENTS OF INERTIA

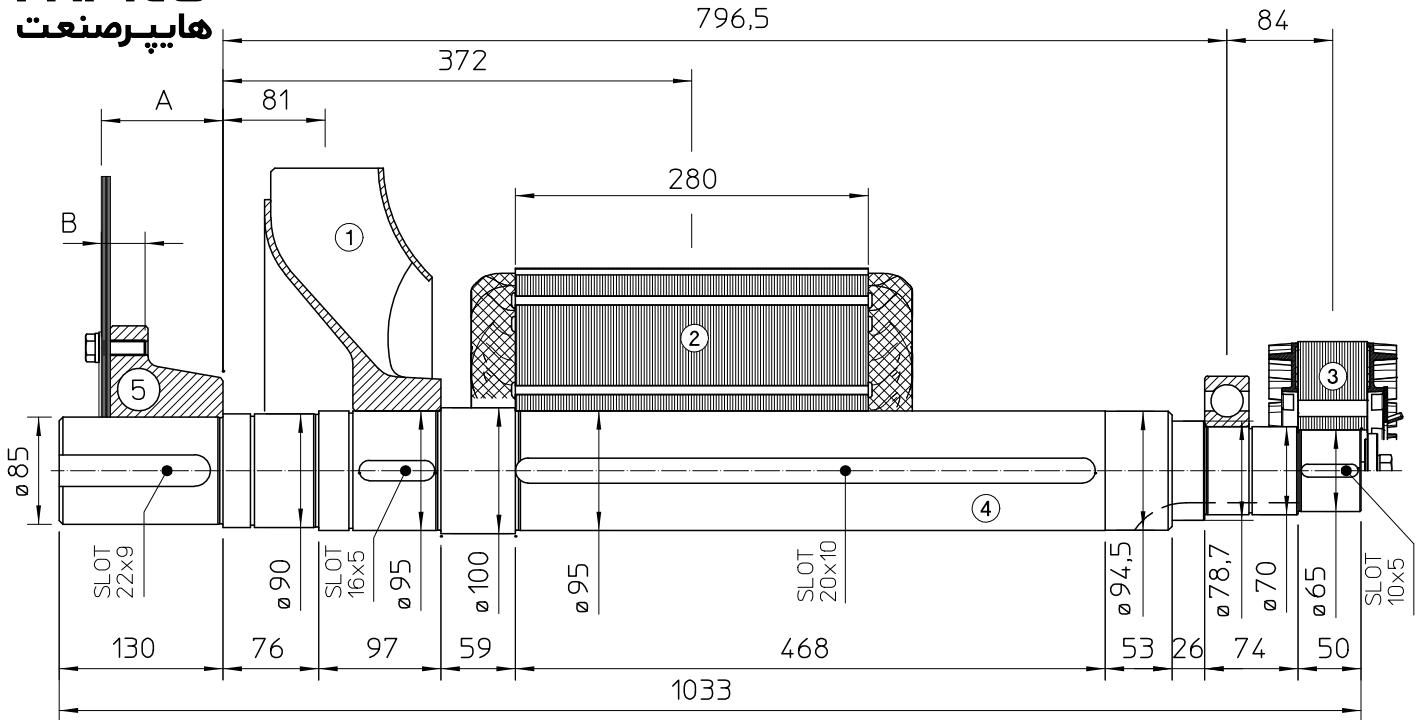

POS.	COMPONENT	WEIGHT (kg)	J (kgm ²)
1	FAN	6.1	0.1887
2	MAIN ROTOR	147.5	2.0195
3	EX. ROTOR	14.5	0.0874
4	SHAFT	49.9	0.0525
TOTAL		218	2.3481

SAE N°	5		SHAFTS COUPLING FLEX PLATE	
	A	B	WEIGHT kg	J kgm ²
11.5	110.4	41.1	20.5	0.174
14	96.4	34.7	23.5	0.275

SINGLE BEARING DIMENSIONS

FAMCO
 هایپر صنعت

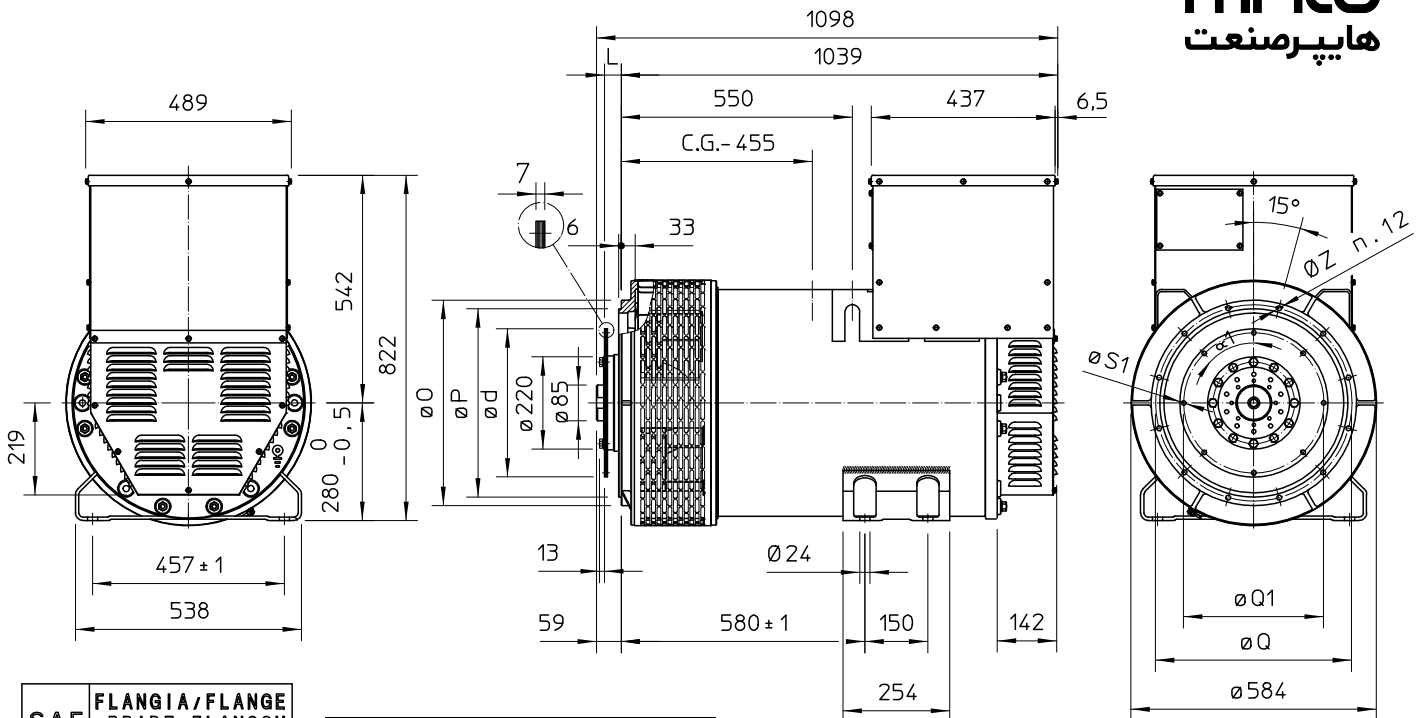

SAE N.	FLANGIA/FLANGE BRIDE/FLANSCH		
	O	P	Q
3	451	409,6	428,6
2	489	447,7	466,7
1	552	511,2	530,2
1/2	648	584,2	619,1

SAE N.	GIUNTI A DISCHI DISC COUPLING DISQUE DE MONOPALIER SCHEIBENKUPPLUNG				
	L	d	Q1	n _{fori}	S1
11 1/2	39,6	352,42	333,37	8	11 45°
14	25,4	466,72	438,15	8	14 45°

C.G.= GRAVITY CENTER

Electrical Characteristics										
Frequency	Hz	50				60				
Voltage (star)	V	380	400	415	440	415	440	460	480	
Rated power class H	kVA	6,5	6,5	6,5	5,5	7	7,8	7,8	7,8	
	kW	5,2	5,2	5,2	4,4	5,6	6,2	6,2	6,2	
Rated power class F	kVA	6	6	6	5	5,5	6,5	7,2	7,2	
	kW	5	5	5	4	4,4	5,2	5,8	5,8	
Regulation with	SR7/2	±1,5 % with any power factor and speed variations between -5% +30%								
Insulation class		H								
Execution		Brushless								
Stator winding		6 ends								
Rotor		without damping cage								
Efficiencies class H (see graph. for details)	4/4	%	81,7	81,8	81,5	81,3	82,6	83,1	83,2	83,3
	3/4	%	82,1	82,4	82,3	82	83,3	83,5	83,7	83,9
	2/4	%	78,8	78,9	78,9	78,6	80,1	80,2	80,3	80,4
	1/4	%	75,1	75	74,8	74,3	76,2	76	76,1	76,4
Reactances (f. l.cl. F)	Xd	%	187,5	169,2	157,2	118,3	203,1	201,4	184,2	169,2
	Xd'	%	18,39	16,6	15,42	11,61	19,93	19,76	18,07	16,6
	Xd''	%	15,62	14,1	13,10	9,86	16,93	16,78	15,35	14,1
	Xq	%	65,8	59,4	55,2	41,5	71,3	70,7	64,7	59,4
	Xq'	%	65,8	59,4	55,2	41,5	71,3	70,7	64,7	59,4
	Xq''	%	75,5	68,1	63,3	47,6	81,8	81,0	74,2	68,1
	X ₂	%	17,15	15,48	14,38	10,83	18,58	18,42	16,86	15,48
	X ₀	%	6,76	6,1	5,67	4,27	7,32	7,26	6,64	6,1
	Short Circuit Ratio	Kcc		0,86	1	1,19	1,50	0,73	0,81	0,86
Time Constants	Td'	sec.	0,026							
	Td''	sec.	0,025							
	Tdo'	sec.	0,71							
	Tα	sec.	0,011							
Short Circuit Current Capacity	%	>300				>320				
Excitation at no load	Amp.	0,28	0,36	0,41	0,48	0,18	0,2	0,22	0,25	
Excitation at full load	Amp.	0,99	1,08	1,1	1,2	0,75	0,8	0,9	0,95	
Overload (long-term)	%	1 hour in a 6 hours period 110% rated load								
Overload per 20 sec.	%	300								
Stator Winding Resistance (20°C)	Ω	1,938								
Rotor Winding Resistance (20°C)	Ω	6,078								
Exciter Resistance (20 °C)	Ω	Rotor : 1,453				Stator : 15,71				
Heat dissipation at f.l.cl.H	W	1165	1157	1180	1012	1180	1269	1260	1251	
Telephone Interference		THF < 2%				TIF < 45				
Radio interference		EN60034-1, VDE 0875 K. For others standards apply to factory								
Waveform Distors.(THD) at f. load	LL/LN %	2,93 / 2,5								
Waveform Distors.(THD) at no load	LL/LN %	2,8 / 2,6								
Mechanical characteristics										
Protection		IP 23 (other protection on request)								
DE bearing		6308-2RS								
NDE bearing		6305-2RS								
Weight of wound stator assembly	kg	18,7								
Weight of wound rotor assembly	kg	10,2								
Weight of complete generator	kg	63								
Maximun overspeed	rpm	2250								
Unbalanced magnetic pull at f.l.cl.F	kN/mm	2,5								
Cooling air requirement	m³/min	3,5				3,9				
Inertia Constant (H)	sec.	0,106				0,127				
Noise level at 1m/7m	dB(A)	72 / 58				78 / 60				

All technical data are to be considered as a reference and they can be modified without any notice

This document is a propriety of Mecc Alte S.p.a..All rights reserved.

50 Hz

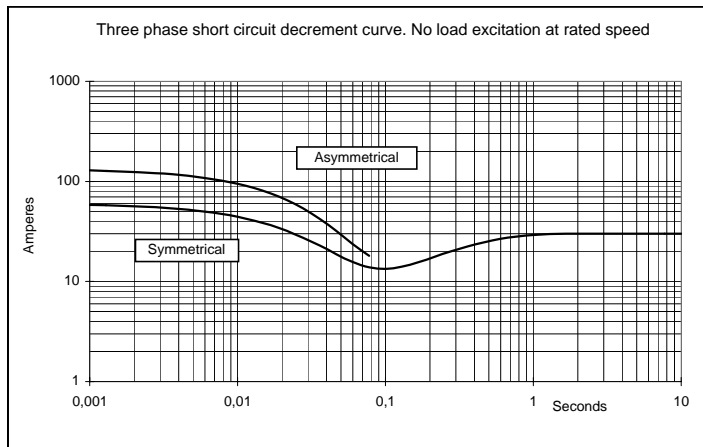
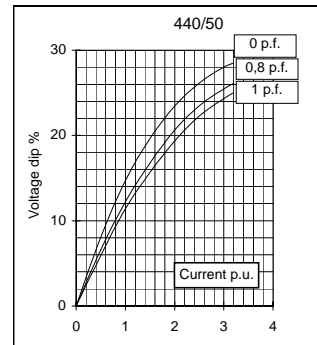
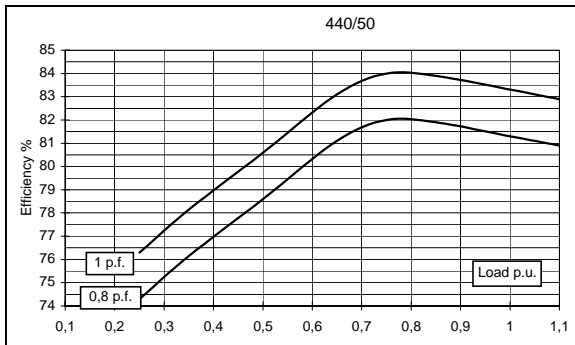
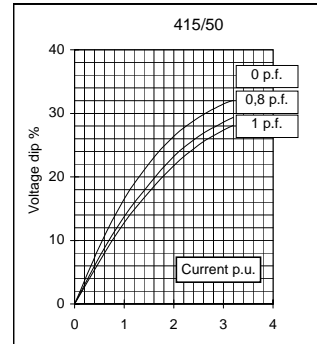
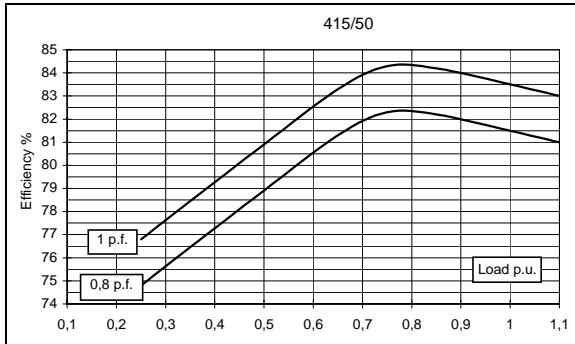
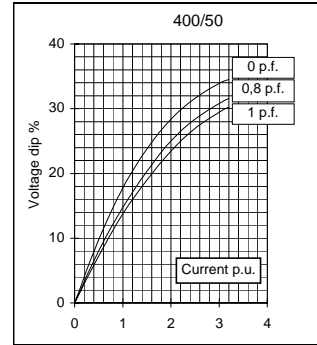
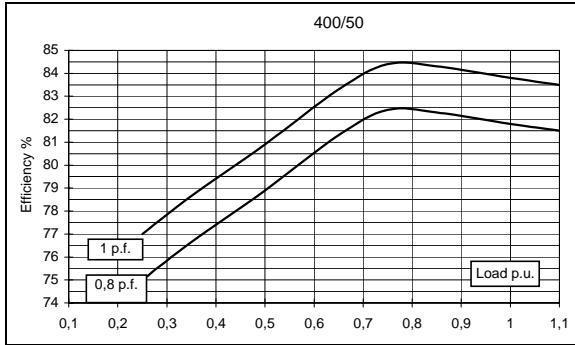
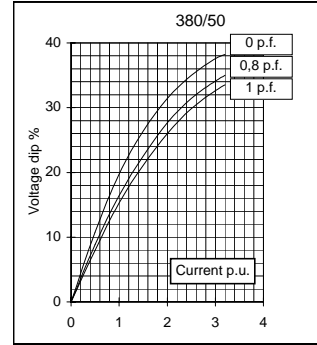
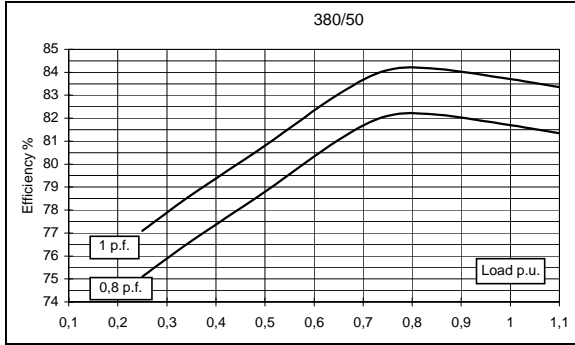

All technical data are to be considered as a reference and they can be modified without any notice
This document is a propriety of Mecc Alte S.p.a.. All rights reserved.

60 Hz

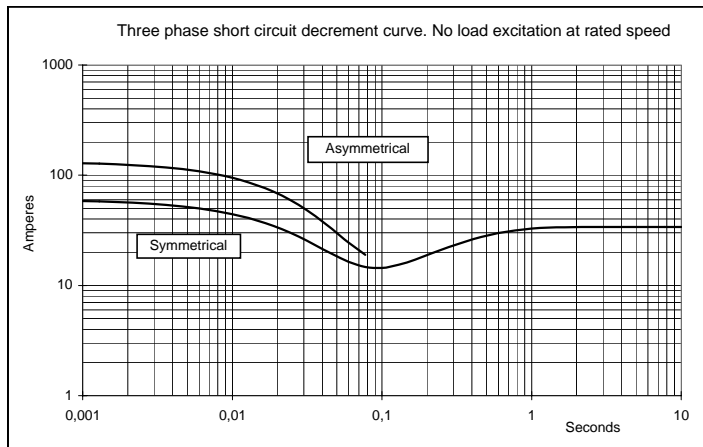
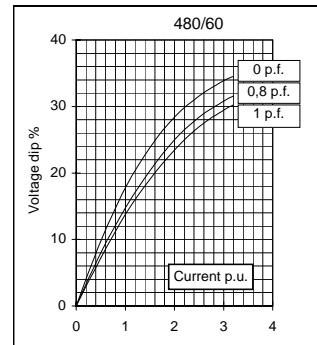
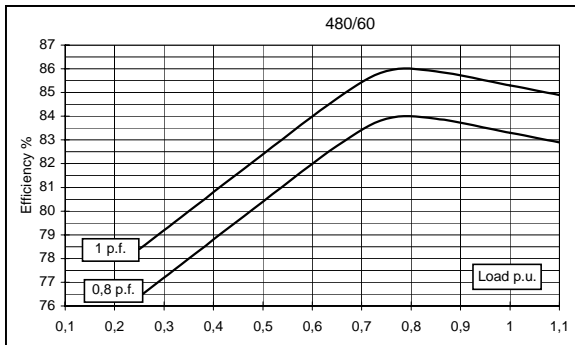
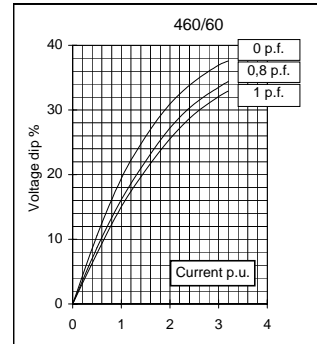
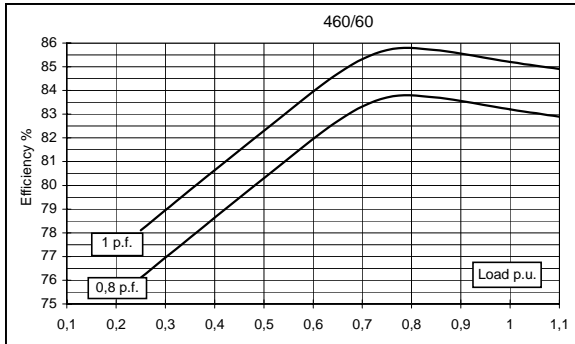
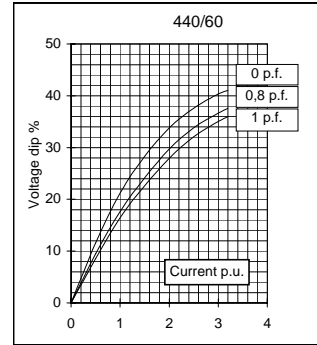
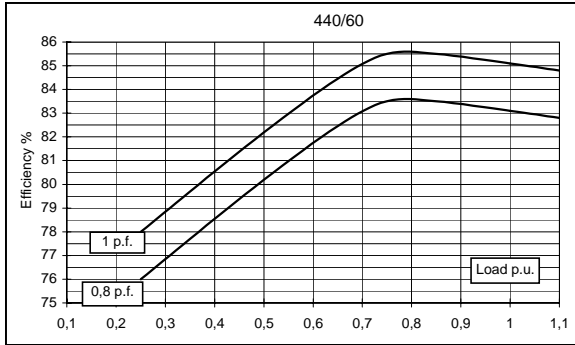
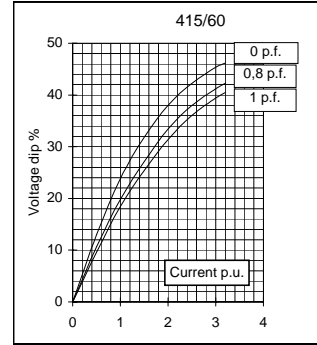
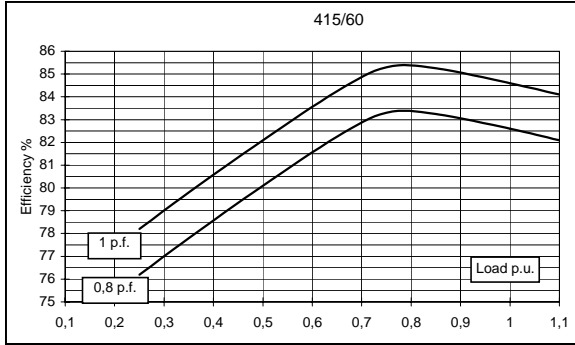

All technical data are to be considered as a reference and they can be modified without any notice

This document is a propriety of Mecc Alte S.p.a.. All rights reserved.

TWO BEARING MOMENTS OF INERTIA

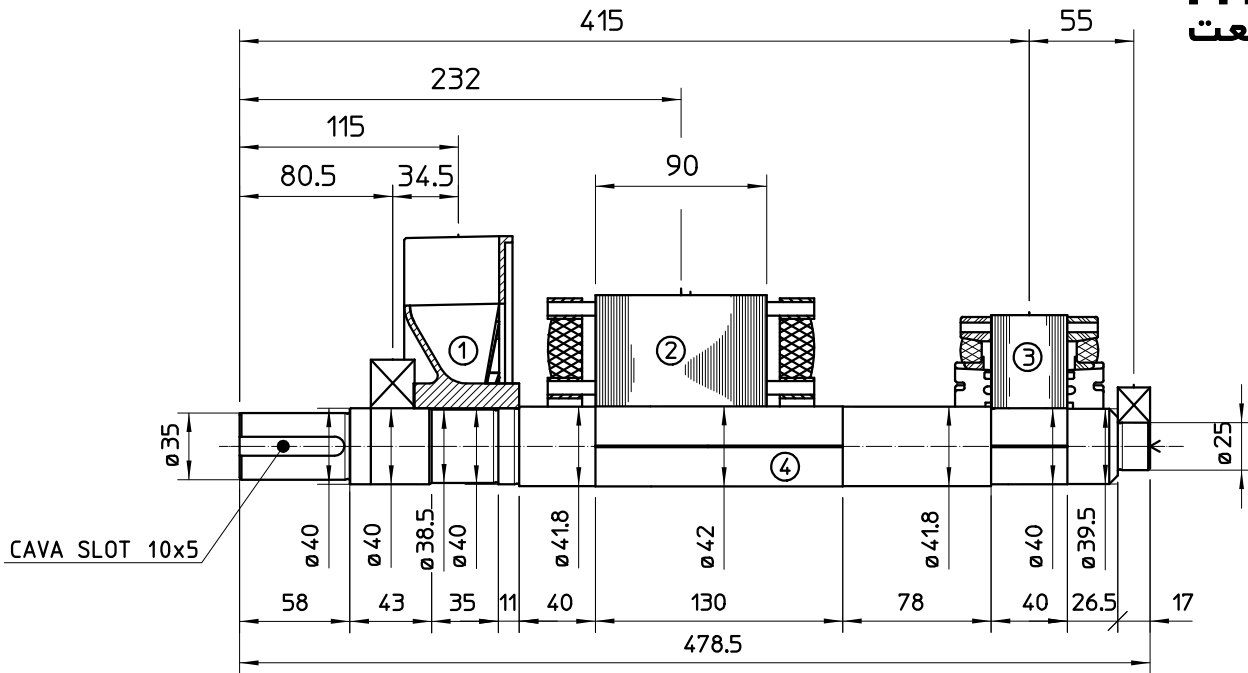

COMPONENT	WEIGHT Kg	J Kg ^m ²
1 FAN	0.93	0.0036
2 MAIN ROTOR	11	0.038
3 EX ROTOR	4.12	0.011
4 SHAFT	4.7	0.00097
6 TOTAL	20.75	0.05357

TWO BEARING DIMENSIONS

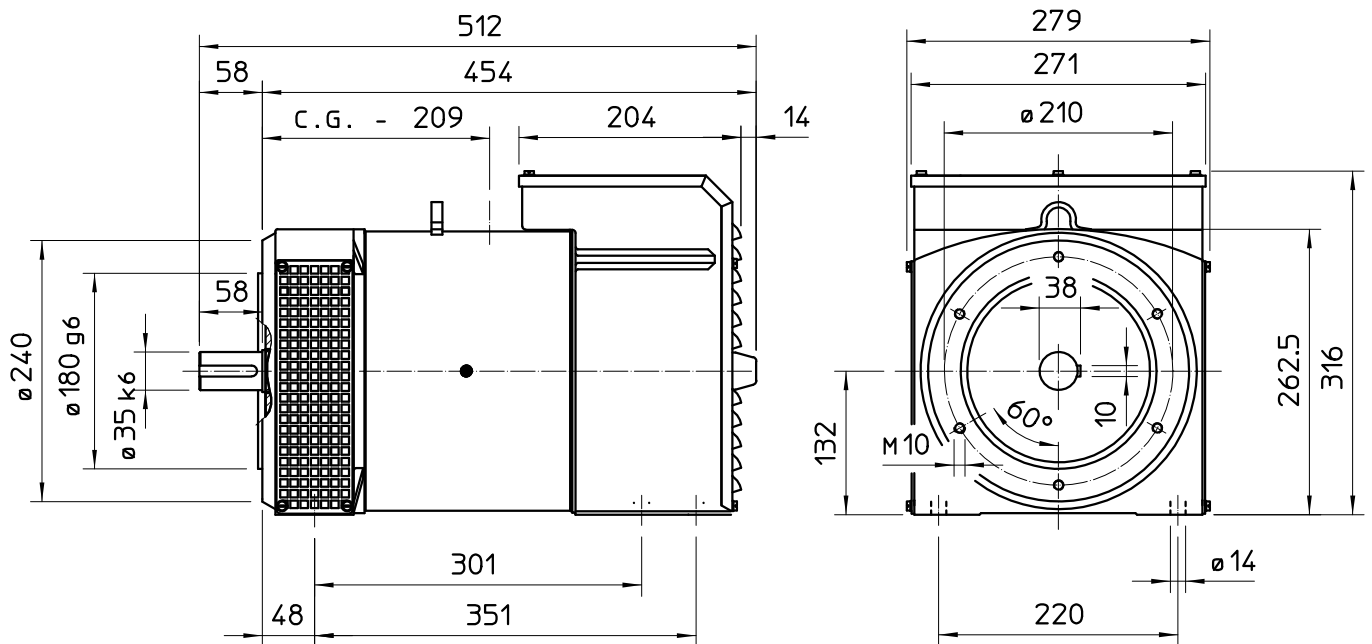

SINGLE BEARING MOMENTS OF INERTIA

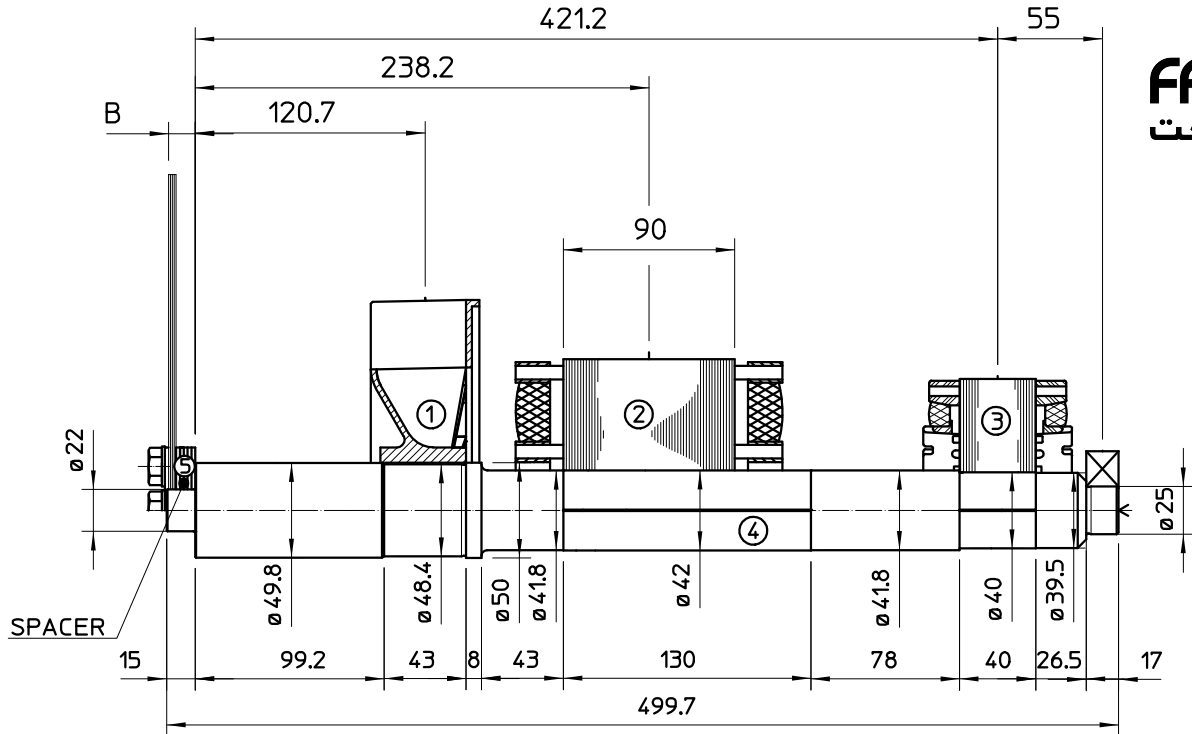

FAMCO
هایپر صنعت

COMPONENT	WEIGHT Kg	J Kg ^m ²
1 FAN	0.82	0.0032
2 MAIN ROTOR	11	0.038
3 EX ROTOR	4.12	0.011
4 SHAFT	5.6	0.0012
6 TOTAL	21.54	0.0534

SAE N.	SHAFT COUPLING FLEX PLATE		
	B (mm)	WEIGHT kg	J kg ^m ²
6 1/2	4	1.14	0.0067
7 1/2	4	1.42	0.0103
8	35.6	1.97	0.0171
10	27.6	2.59	0.0319
11 1/2	14	3.1	0.0481

FAMCO
هایپر صنعت

SINGLE BEARING DIMENSIONS

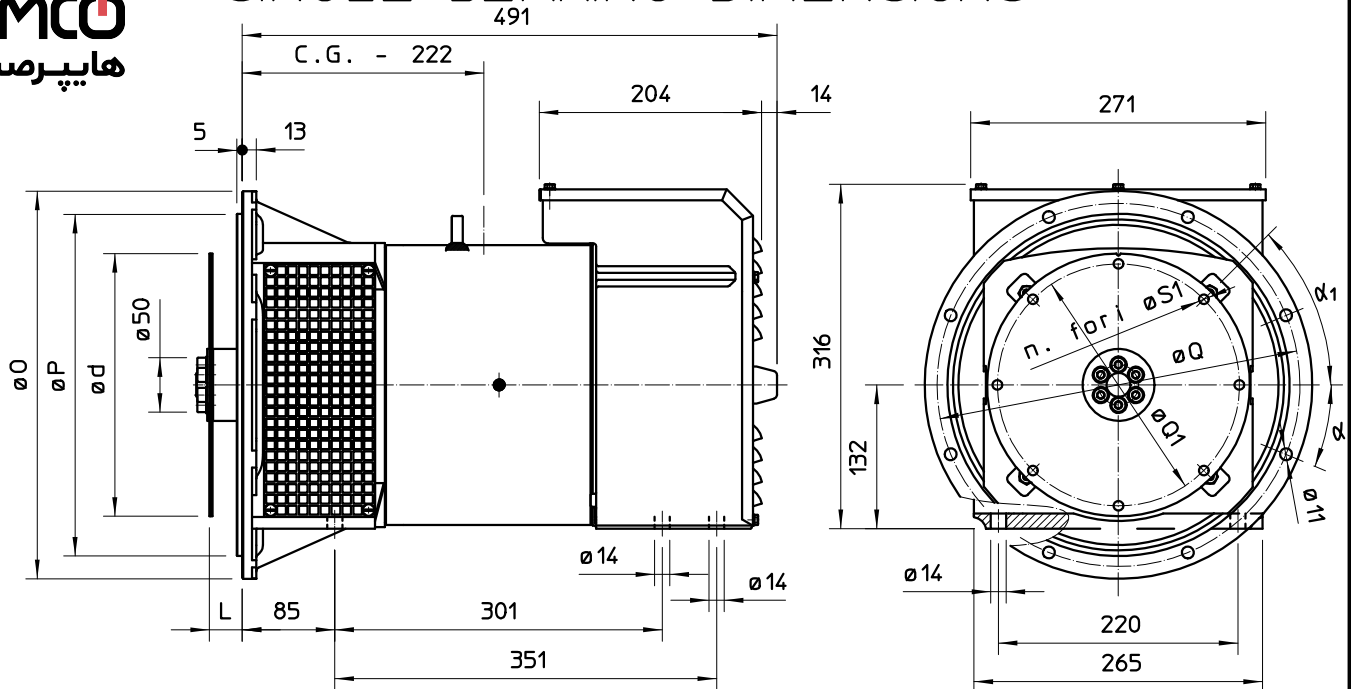

GIUNTI A DISCO COUPLING DISC PLATEX
DISQUE DE MONOPALIER SCHEIBENKUPPLUNG
JUNTAS A DISCOS

FLANGIA FLANGE BRIDE FLANSCH BRIDAS	SAE N.	O	P	Q	n. fori	α
	6	308	266.7	285.75	8	22°30'
	5	356	314.3	333.4	8	22°30'
	4	403	362	381	12	15°
	3	451	409.6	428.6	12	15°

SAE N.	L	d	Q1	n. fori	S1	α1
6 1/2	30.2	215.9	200	6	9	60°
7 1/2	30.2	241.3	222.25	8	9	45°
8	62	263.52	244.47	6	11	60°
10	53.8	314.32	295.27	8	11	45°
11 1/2	39.6	352.42	333.37	8	11	45°

C.G. = GRAVITY CENTER



Electrical Characteristics										
Frequency	Hz	50				60				
Voltage (series star)	V	380	400	415	440	415	440	460	480	
Rated power class H	kVA	350	350	350	340	380	420	420	420	
	kW	280	280	280	272	304	336	336	336	
Rated power class F	kVA	320	320	320	310	350	385	385	385	
	kW	256	256	256	248	280	308	308	308	
Regulation with DSR		±1 % with any power factor and speed variations between -5% +30%								
Insulation class		H								
Execution		Brushless								
Stator winding		12 ends								
Rotor		with damping cage								
Efficiencies class H	4/4	%	93,4	93,5	93,2	93	93,6	94,1	94,2	94,3
(see graph. for details)	3/4	%	93,4	93,7	93,6	93,3	93,9	94,1	94,3	94,5
	2/4	%	92,5	92,6	92,6	92,4	93	93,1	93,2	93,3
	1/4	%	90,1	89,9	89,7	89,5	90,6	90,6	90,6	90,4
Reactances (f. l.cl. F)	Xd	%	238,2	215	199,7	172,6	260,2	255,9	234,1	215
	Xd'	%	19,1	17,2	16,0	13,8	20,8	20,5	18,7	17,2
	Xd''	%	10,4	9,4	8,7	7,5	11,4	11,2	10,2	9,4
	Xq	%	139,6	126	117,1	101,2	152,5	150,0	137,2	126
	Xq'	%	139,6	126	117,1	101,2	152,5	150,0	137,2	126
	Xq''	%	22,3	20,1	18,7	16,1	24,3	23,9	21,9	20,1
	X ₂	%	17,4	15,7	14,6	12,6	19,0	18,7	17,1	15,7
	X ₀	%	2,4	2,2	2,0	1,8	2,7	2,6	2,4	2,2
Short Circuit Ratio	Kcc		0,37	0,42	0,57	0,92	0,24	0,32	0,37	0,42
Time Constants	Td'	sec.	0,099							
	Td''	sec.	0,0127							
	Tdo'	sec.	1,50							
	Tα	sec.	0,013							
Short Circuit Current Capacity		%	>300				>350			
Excitation at no load	Amp.		0,55	0,72	0,95	1,2	0,35	0,35	0,6	0,7
Excitation at full load	Amp.		3,5	3,9	4,1	4,3	3,3	3,5	3,7	3,9
Overload (long-term)		%	1 hour in a 6 hours period 110% rated load							
Overload per 20 sec.		%	300							
Stator Winding Resistance (20 °C)		Ω	0,0042							
Rotor Winding Resistance (20 °C)		Ω	6,780							
Exciter Resistance (20 °C)		Ω	Rotor : 0,685				Stator : 15,28			
Heat dissipation at f.l.cl.H	W		19786	19465	20429	20473	20786	21067	20688	20310
Telephone Interference			THF < 2%				TIF < 40			
Radio interference			EN61000-6-3, EN61000-6-2. For others standards apply to factory							
Waveform Distors.(THD) at f. load	LL/LN %		3,1 / 2,9							
Waveform Distors.(THD) at no load	LL/LN %		2,7 / 2,7							
Mechanical characteristics										
Protection			IP 21 (other protection on request)							
DE bearing			6318.2RS							
NDE bearing			6314.2RS							
Weight of wound stator assembly	kg		347							
Weight of wound rotor assembly	kg		230							
Weight of complete generator	kg		905							
Maximun overspeed	rpm		2250							
Unbalanced magnetic pull at f.l.cl.F	kN/mm		6,2							
Cooling air requirement	m ³ /min		32				39			
Inertia Constant (H)	sec.		0,123				0,147			
Noise level at 1m/7m	dB(A)		82 / 69				86 / 73			

All technical data are to be considered as a reference and they can be modified without any notice.

This document is a propriety of Mecc Alte S.p.a..All rights reserved.

50 Hz

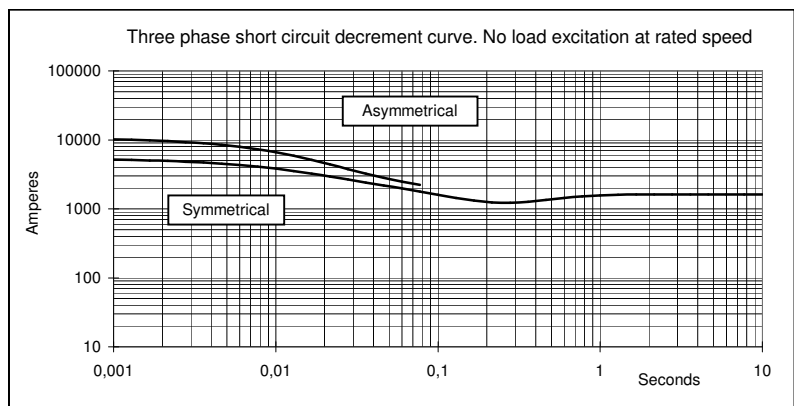
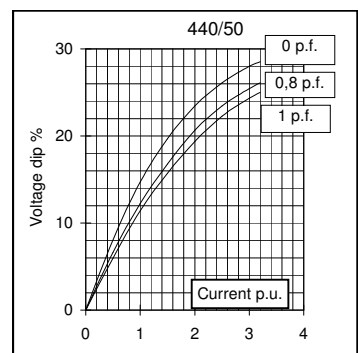
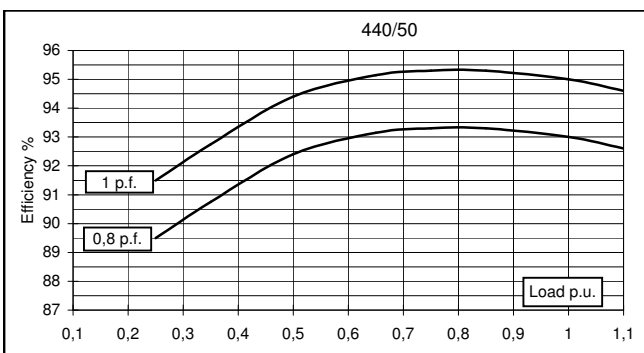
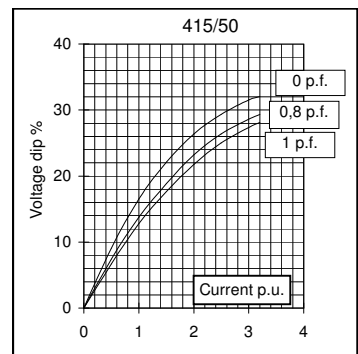
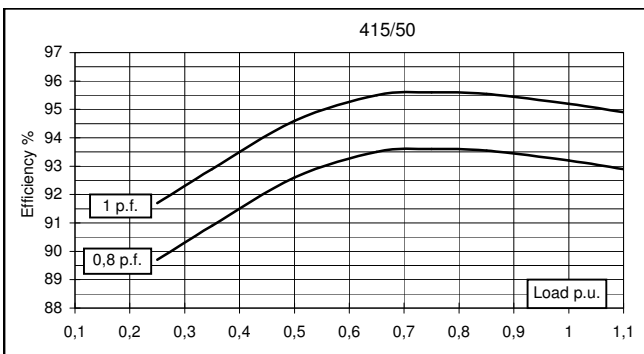
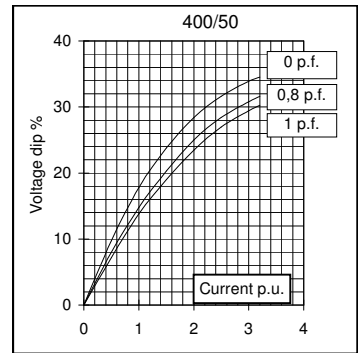
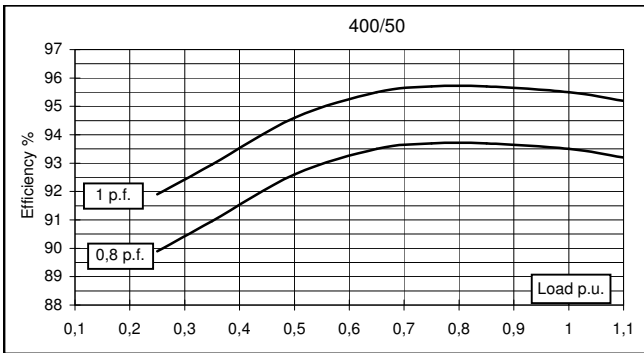
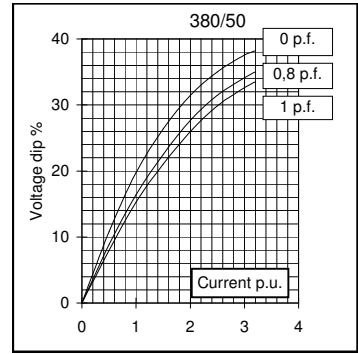
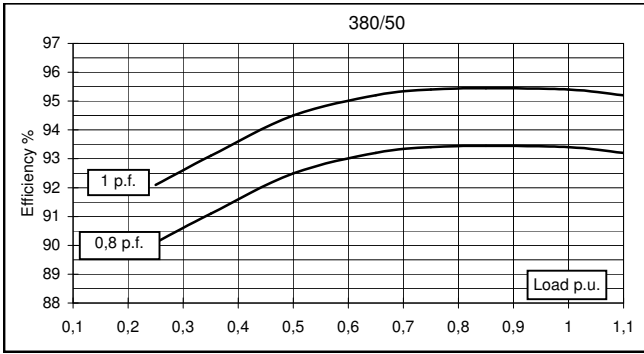

This document is a propriety of Mecc Alte S.p.a.. All rights reserved.

60 Hz

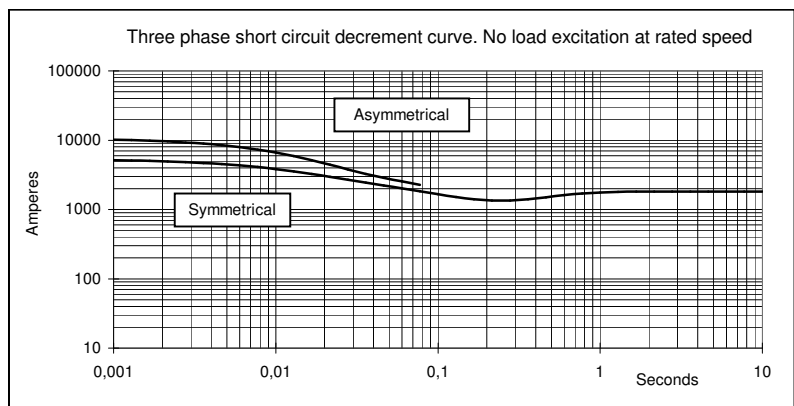
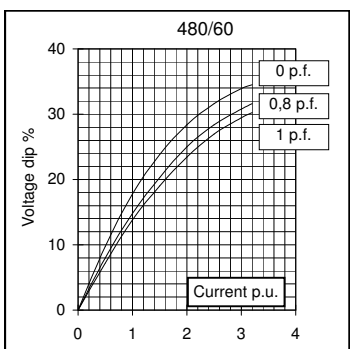
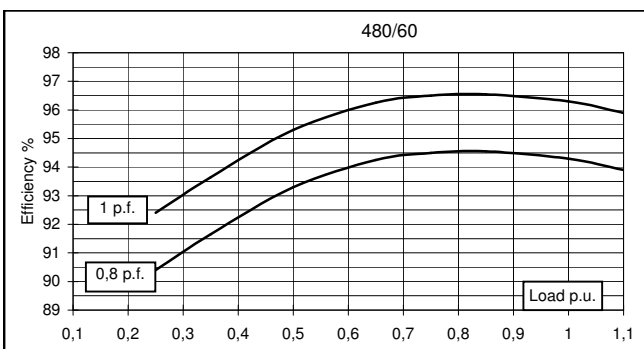
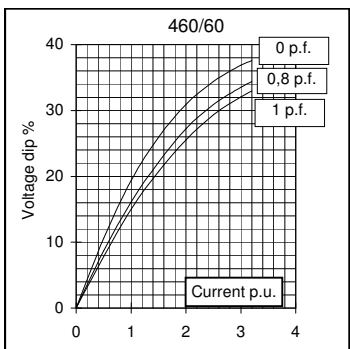
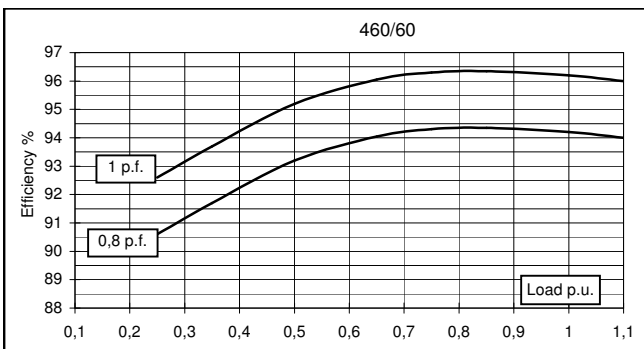
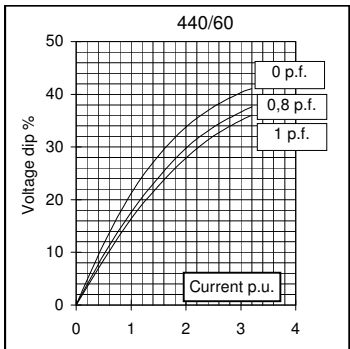
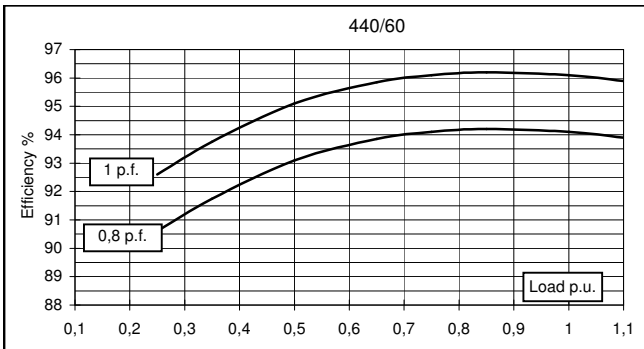
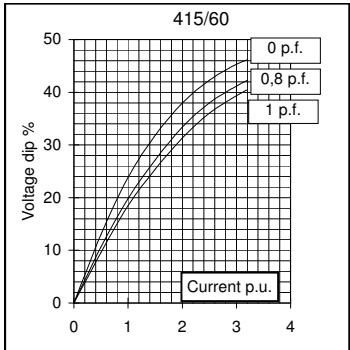
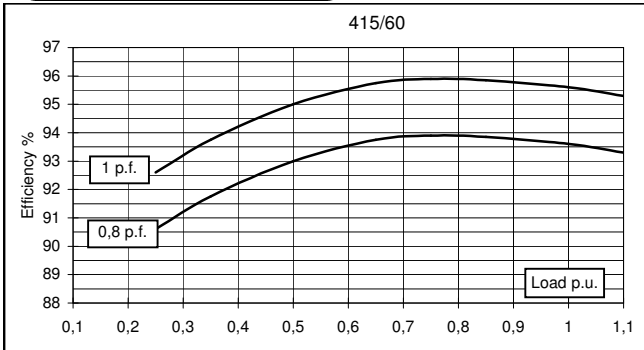

This document is a propriety of Mecc Alte S.p.a.. All rights reserved.

TWO BEARING MOMENTS OF INERTIA

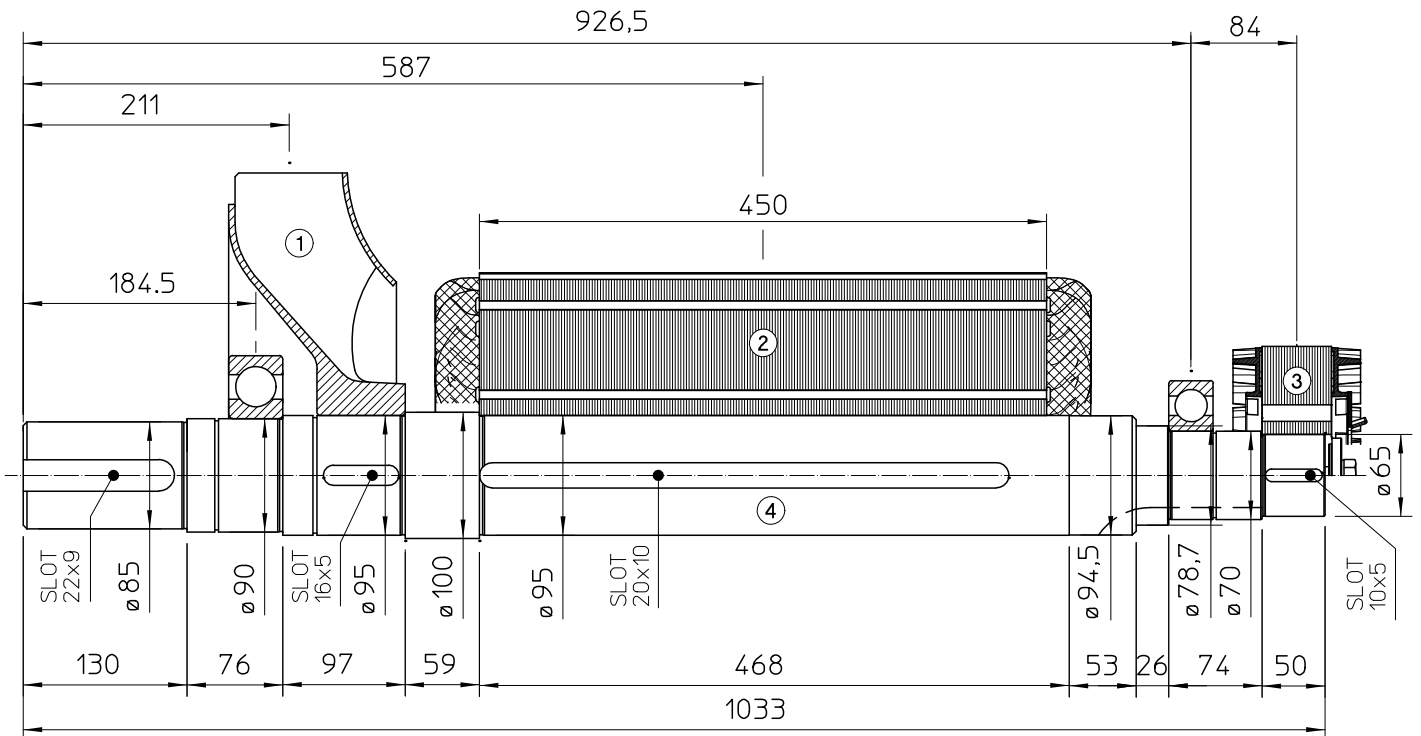

TWO BEARING DIMENSIONS

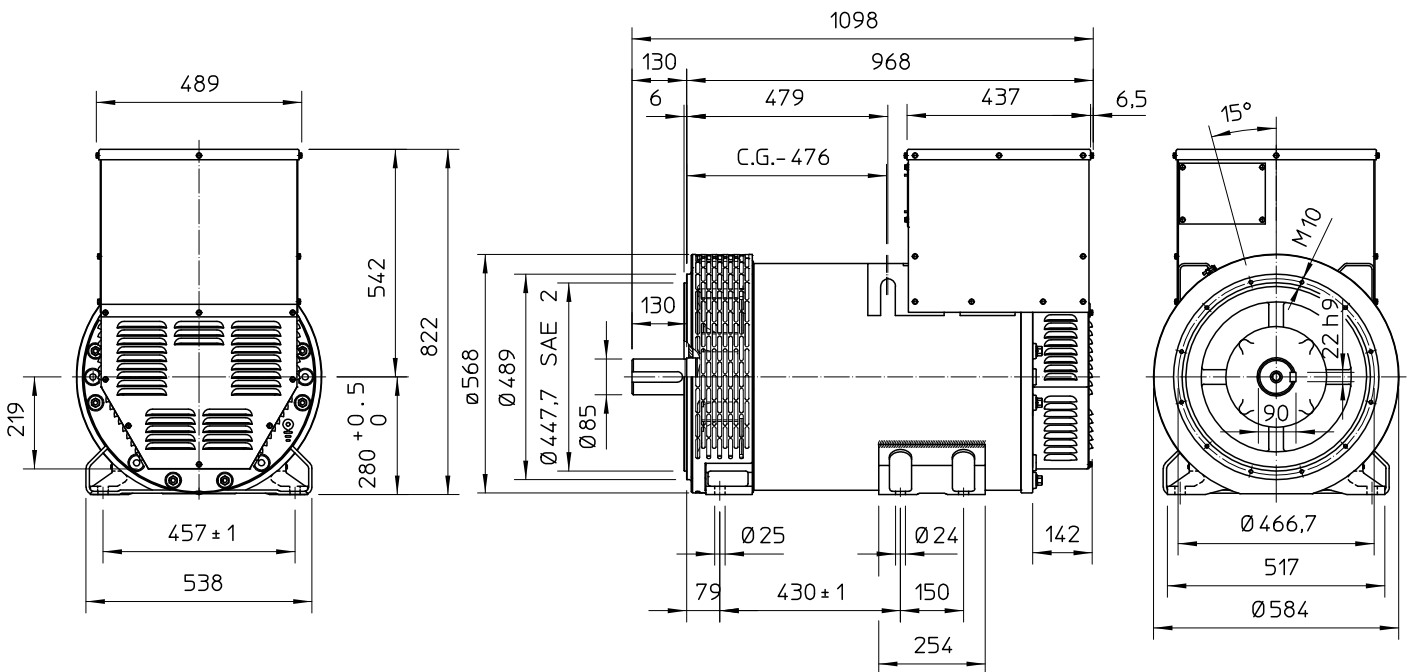

C.G.= GRAVITY CENTER



SINGLE BEARING MOMENTS OF INERTIA

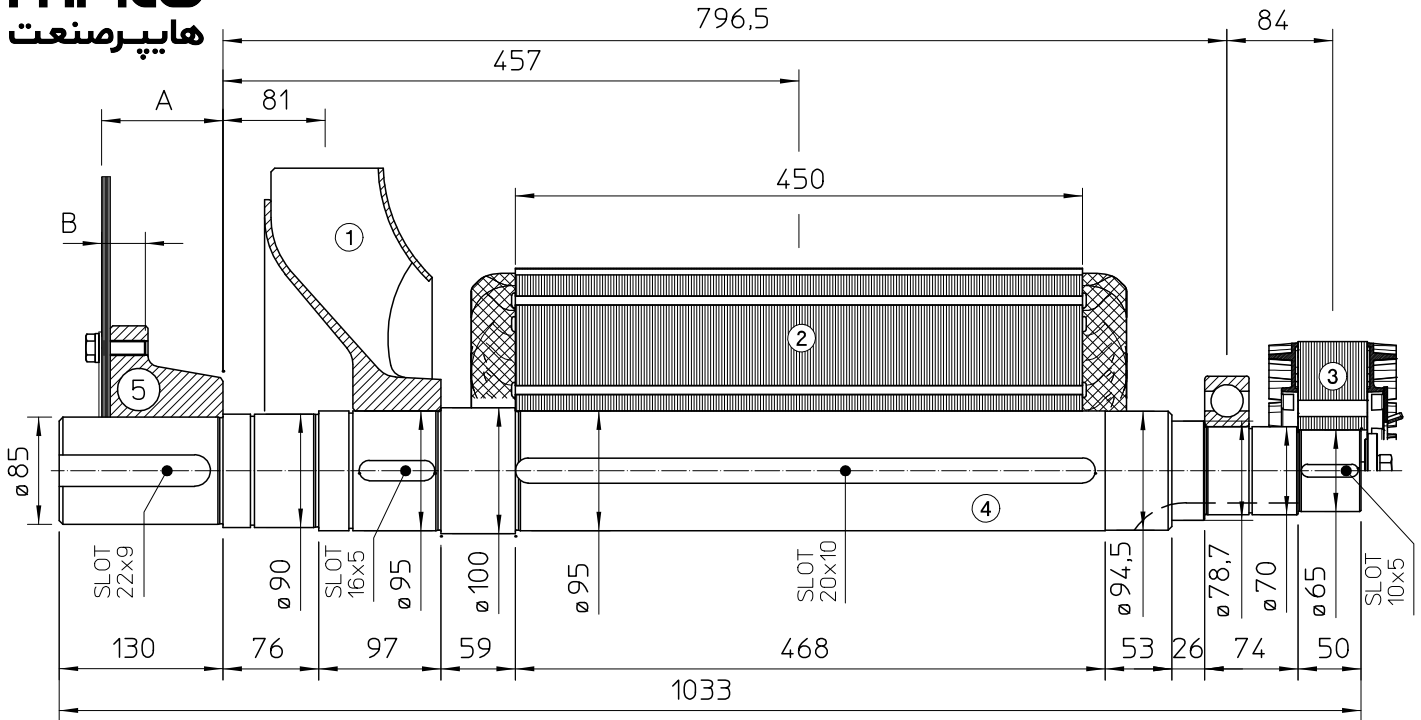

POS.	COMPONENT	WEIGHT (kg)	J (kgm ²)
1	FAN	6.1	0.1887
2	MAIN ROTOR	230	3.1461
3	EX. ROTOR	14.5	0.0874
4	SHAFT	49.9	0.0525
TOTAL		300.5	3.4747

SAE N°	5		SHAFTS COUPLING FLEX PLATE	
	A	B	WEIGHT kg	J kgm ²
11.5	110.4	41.1	20.5	0.174
14	96.4	34.7	23.5	0.275

SINGLE BEARING DIMENSIONS

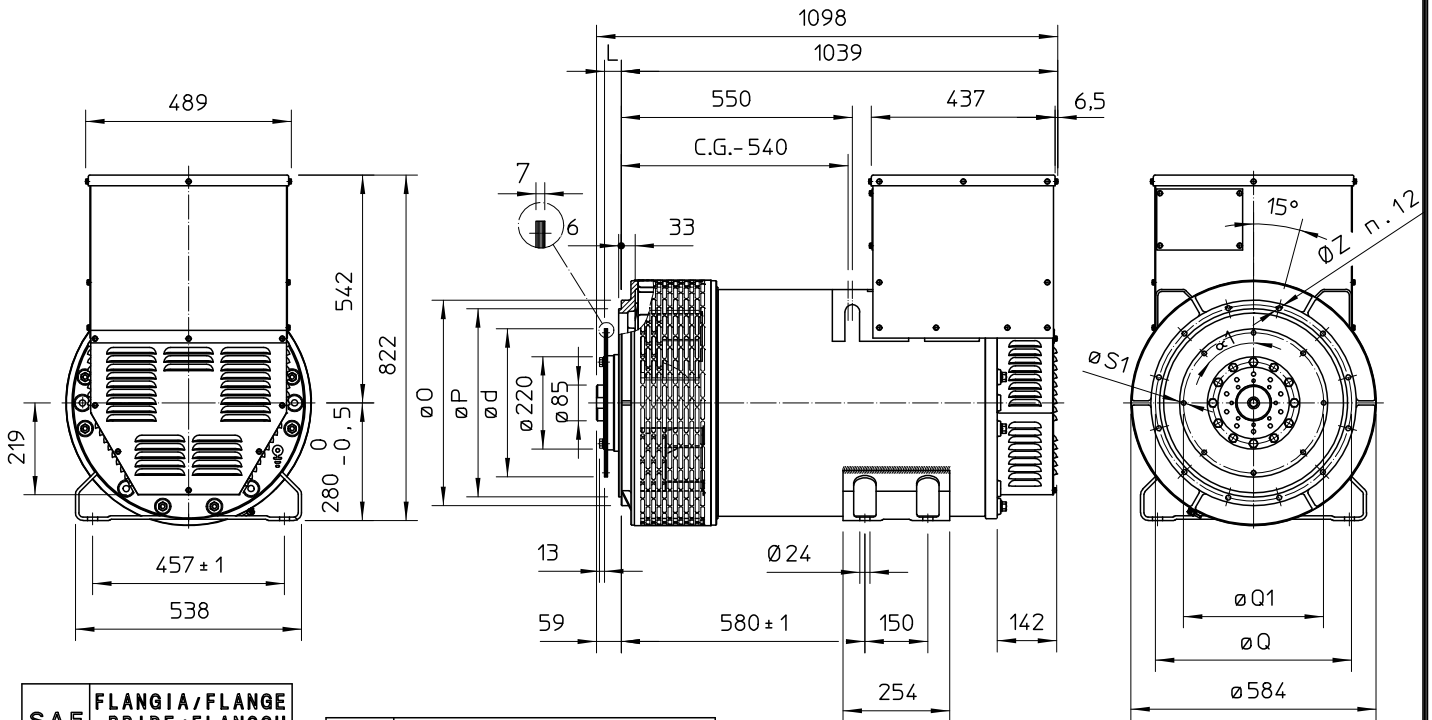

SAE N.	FLANGIA/FLANGE BRIDE/FLANSCH		
	O	P	Q
3	451	409,6	428,6
2	489	447,7	466,7
1	552	511,2	530,2
1/2	648	584,2	619,1

SAE N.	GIUNTI A DISCHI DISC COUPLING DISQUE DE MONOPALIER SCHEIBENKUPPLUNG					
	L	d	Q1	n _{fori}	S1	α 1
11 1/2	39,6	352,42	333,37	8	11	45°
14	25,4	466,72	438,15	8	14	45°



C.G.= GRAVITY CENTER

Electrical Characteristics										
Frequency	Hz	50				60				
Voltage (series star)	V	380	400	415	440	415	440	460	480	
Rated power class H	kVA	125	125	125	105	130	140	150	150	
	kW	100	100	100	84	104	112	120	120	
Rated power class F	kVA	113	113	113	95	116	125	136	136	
	kW	90,4	90,4	90,4	76	92,8	100	109	109	
Regulation with UVR6		±1% with any power factor and speed variations between -5% +30%								
Insulation class		H								
Execution		Brushless								
Stator winding		12 ends								
Rotor		with damping cage								
Efficiencies class H	4/4	%	92,7	92,8	92,5	92,3	93,8	94,3	94,4	94,5
(see graph. for details)	3/4	%	92,9	93,2	93,1	92,8	94,4	94,6	94,7	94,9
	2/4	%	91,3	91,4	91,4	91,2	92,8	92,9	93	93,1
	1/4	%	88,2	88	87,8	87,8	89,2	89,2	89,2	89
Reactances (f. l.cl. F)	Xd	%	227,1	205	190,4	142,3	237,7	227,7	223,2	205
	Xd'	%	18,3	16,5	15,3	11,5	19,1	18,3	18,0	16,5
	Xd''	%	7,2	6,5	6,0	4,5	7,5	7,2	7,1	6,5
	Xq	%	156,7	141,4	131,4	98,2	163,9	157,1	154,0	141,4
	Xq'	%	156,7	141,4	131,4	98,2	163,9	157,1	154,0	141,4
	Xq''	%	31,8	28,7	26,7	19,9	33,3	31,9	31,2	28,7
	X ₂	%	19,6	17,7	16,4	12,3	20,5	19,7	19,3	17,7
	X ₀	%	3,1	2,8	2,6	1,9	3,2	3,1	3,0	2,8
Short Circuit Ratio	Kcc		0,41	0,51	0,63	0,98	0,32	0,37	0,41	0,51
Time Constants	Td'	sec.	0,0372							
	Td''	sec.	0,0076							
	Tdo'	sec.	1,80							
	Tα	sec.	0,0163							
Short Circuit Current Capacity		%	>300				>350			
Excitation at no load	Amp.		0,5	0,55	0,6	0,8	0,2	0,3	0,4	0,5
Excitation at full load	Amp.		2,2	2,3	2,4	2,6	2	2,2	2,3	2,4
Overload (long-term)		%	1 hour in a 6 hours period 110% rated load							
Overload per 20 sec.		%	300							
Stator Winding Resistance (20°C)	Ω		0,018							
Rotor Winding Resistance (20°C)	Ω		3,165							
Exciter Resistance (20 °C)	Ω		Rotor : 0,410				Stator : 15,28			
Heat dissipation at f.l.cl.H	W		7875	7759	8108	7008	6874	6770	7119	6984
Telephone Interference			FHT < 2%				TIF < 40			
Radio interference			EN50081-1; EN50082-1; VDE0875K. For others standards apply to factory							
Waveform Distors.(THD) at f. load	LL/LN %		1,8 / 1,9							
Waveform Distors.(THD) at no load	LL/LN %		2,4 / 2,5							
Mechanical characteristics										
Protection			IP 21 (other protection on request)							
DE bearing			6314.2RS							
NDE bearing			6311.2RS							
Weight of wound stator assembly	kg		142							
Weight of wound rotor assembly	kg		90							
Weight of complete generator	kg		431							
Maximun overspeed	rpm		2250							
Unbalanced magnetic pull at f.l.cl.F	kN/mm		5,4							
Cooling air requirement	m ³ /min		19,3				23			
Inertia Constant (H)	sec.		0,102				0,122			
Noise level at 1m/7m	dB(A)		79 / 65				83 / 69			

This document is a propriety of Mecc Alte S.p.a..All rights reserved.

50 Hz

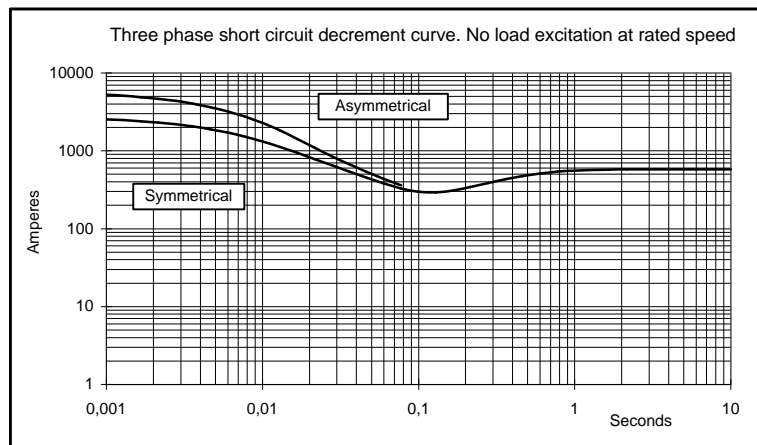
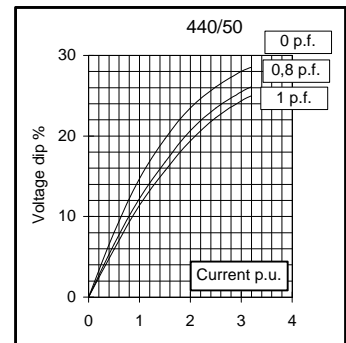
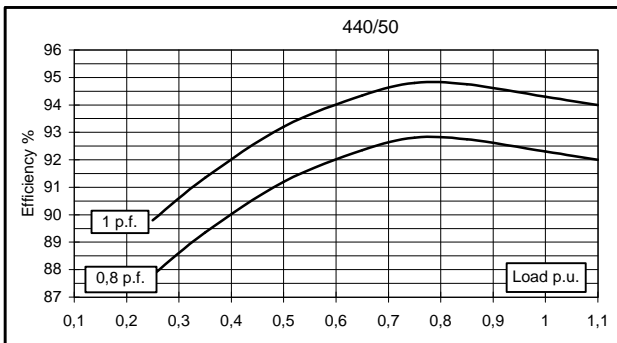
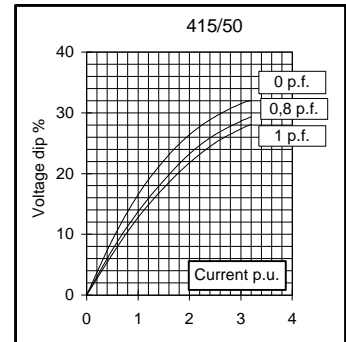
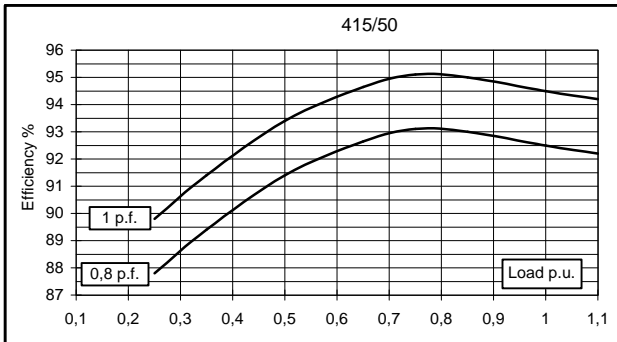
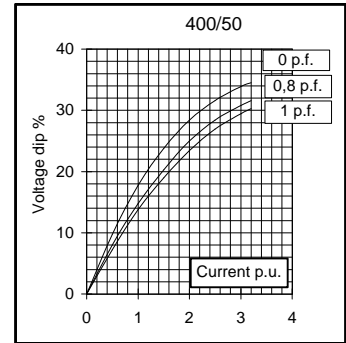
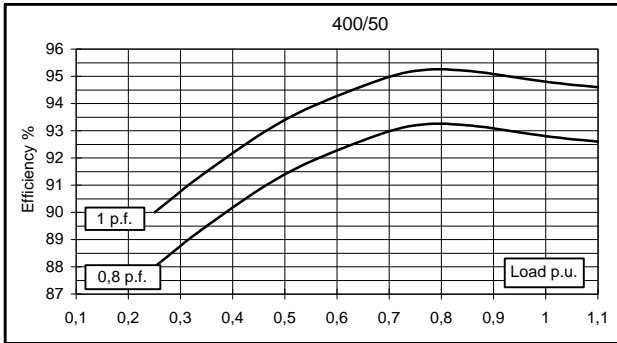
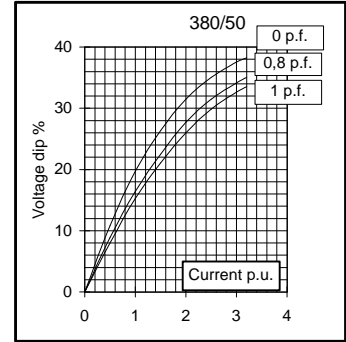
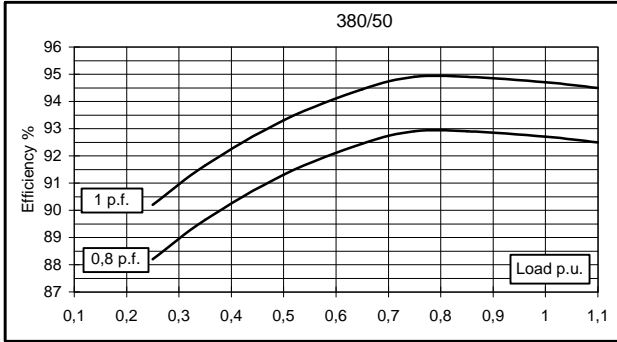

This document is a propriety of Mecc Alte S.p.a.. All rights reserved.

60 Hz

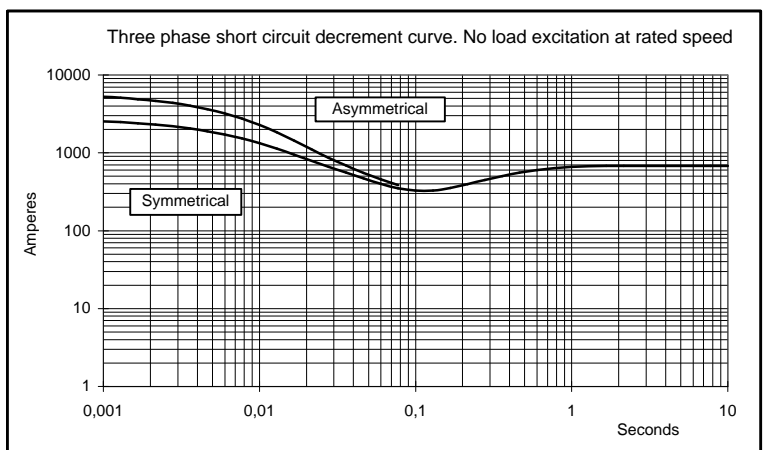
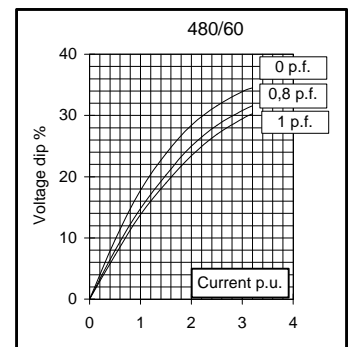
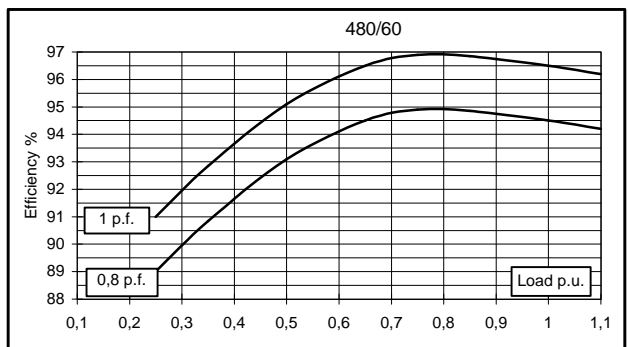
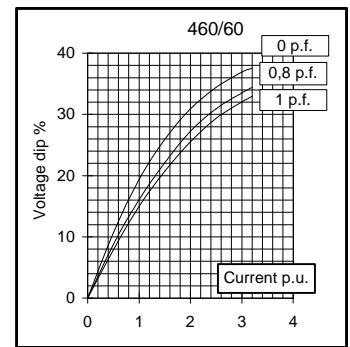
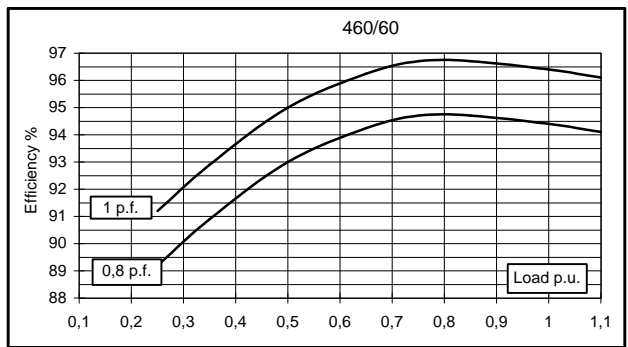
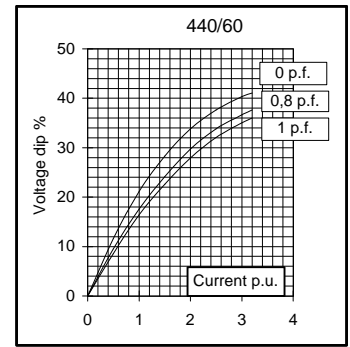
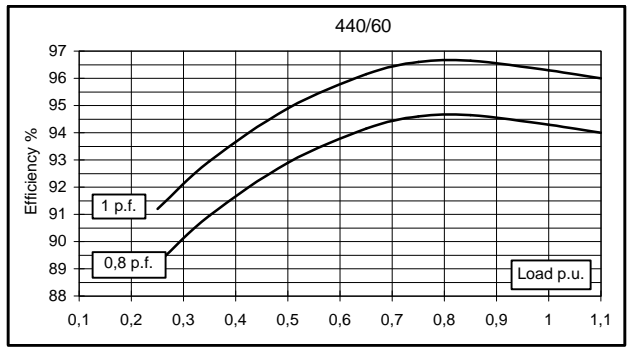
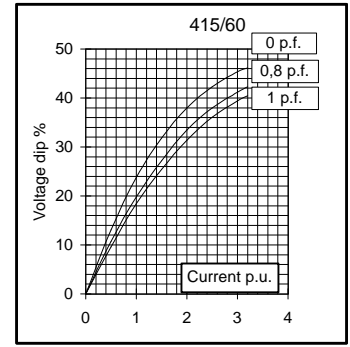
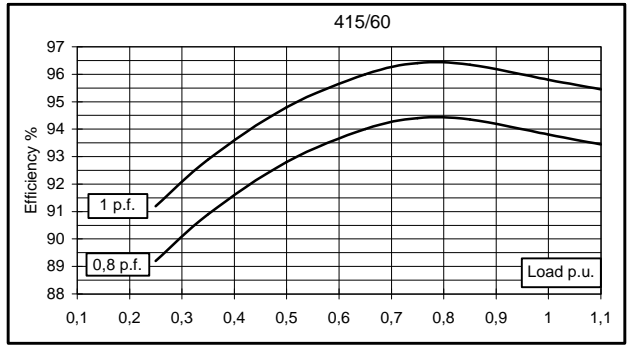

This document is a propriety of Mecc Alte S.p.a.. All rights reserved.

TWO BEARING MOMENTS OF INERTIA

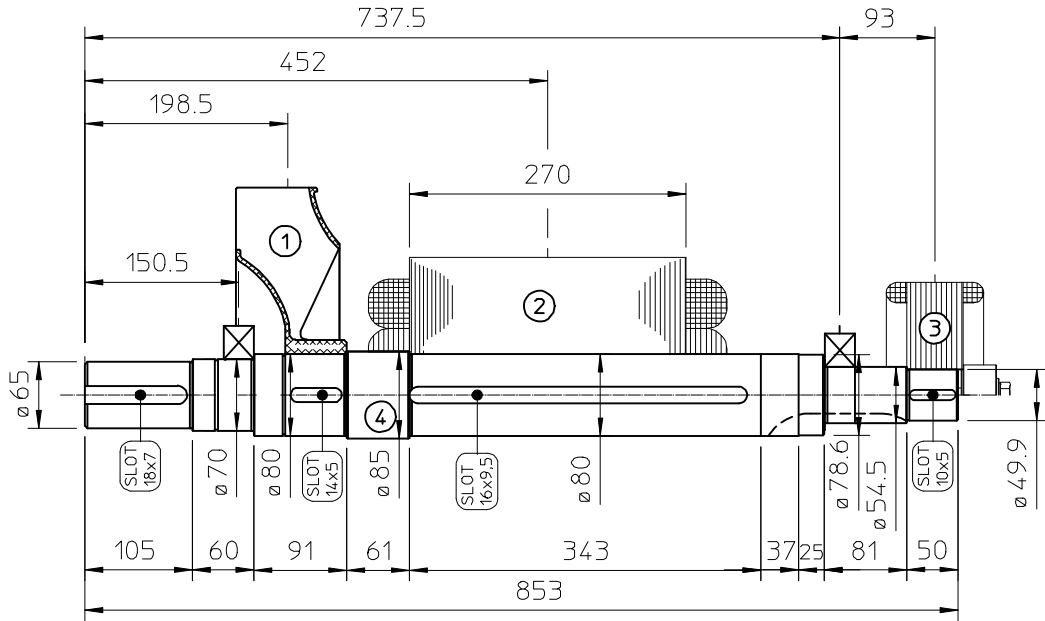

COMPONENT	WEIGHT kg	J kgm ²
1 FAN	3,3	0,0451
2 MAIN ROTOR	90	0.8772
3 EX. ROTOR	14,5	0,0874
4 SHAFT	28,1	0.0211
TOTAL	135,9	1.0308

FAMCO
هایپرمنت

TWO BEARING DIMENSIONS

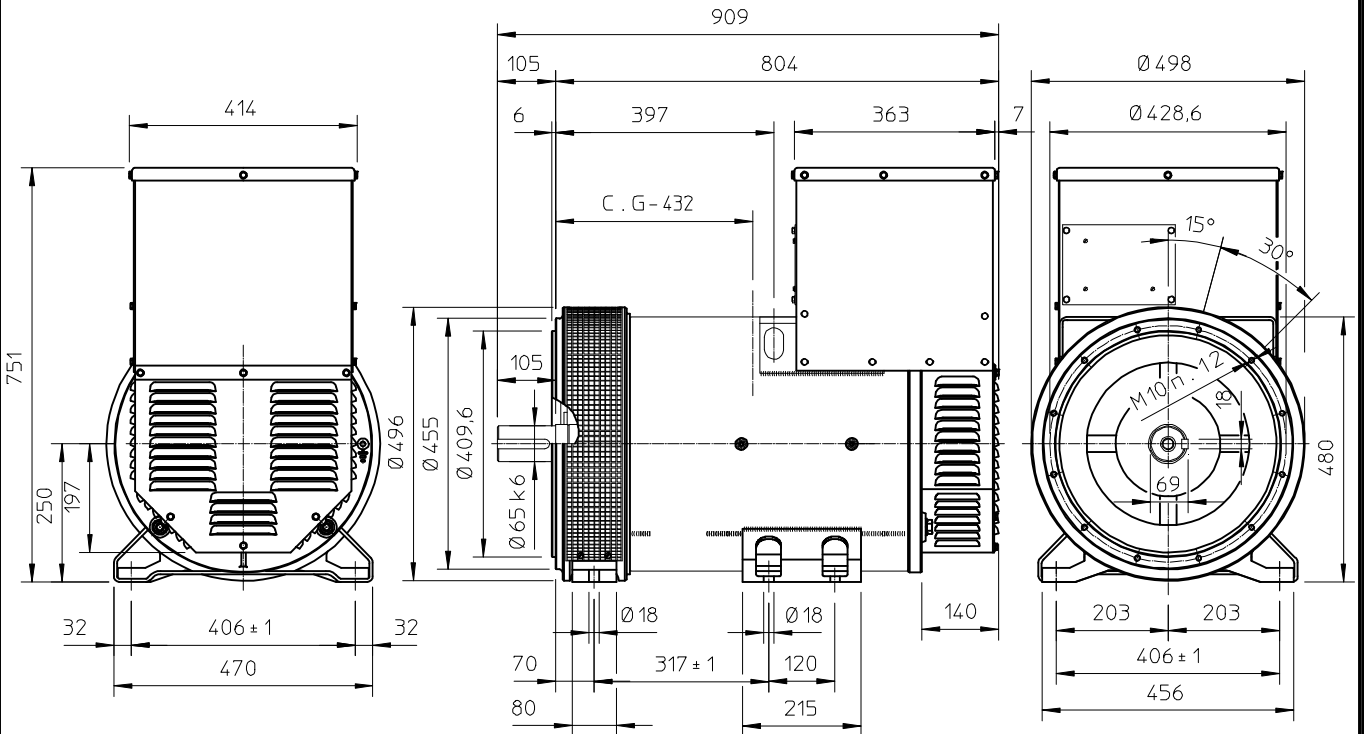

C G = GRAVITY CENTER

SINGLE BEARING MOMENTS OF INERTIA

FAMCO
هایپرمنت

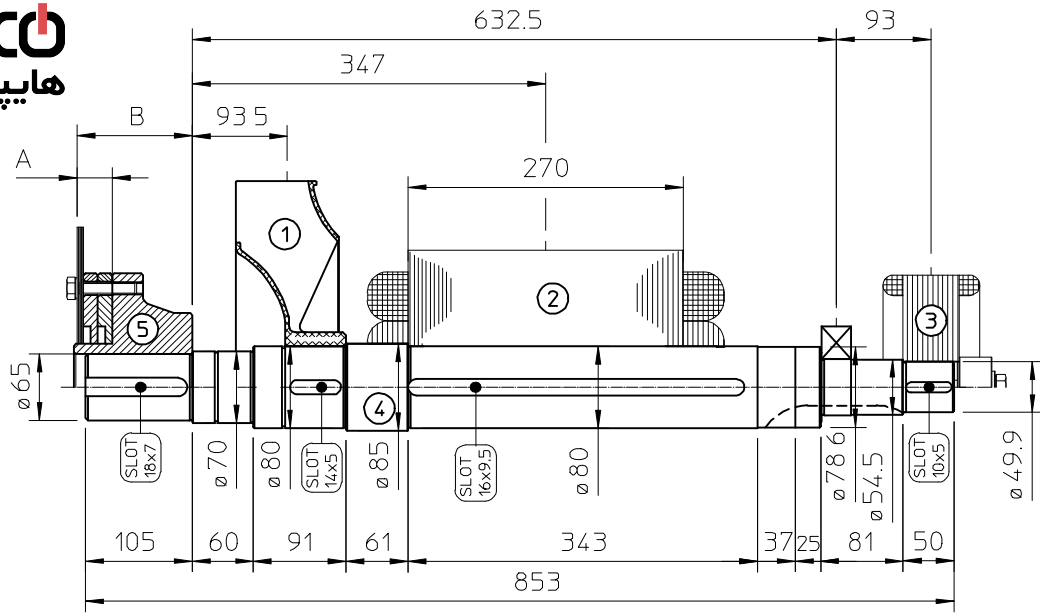

COMPONENT	WEIGHT kg	J kgm ²
1 FAN	3,3	0,0451
2 MAIN ROTOR	90	0,8772
3 EX. ROTOR	14,5	0,0874
4 SHAFT	28,1	0,0211
TOTAL	135,9	1,0308

SAE No	SHAFTS COUPLING FLEX PLATE			
	A	B	WEIGHT kg	J kgm ²
10	46,5	112,8	20,5	0,1342
11,5	37,3	98,6	19,3	0,1512
14	27,4	84,4	21,1	0,2752

SINGLE BEARING DIMENSIONS

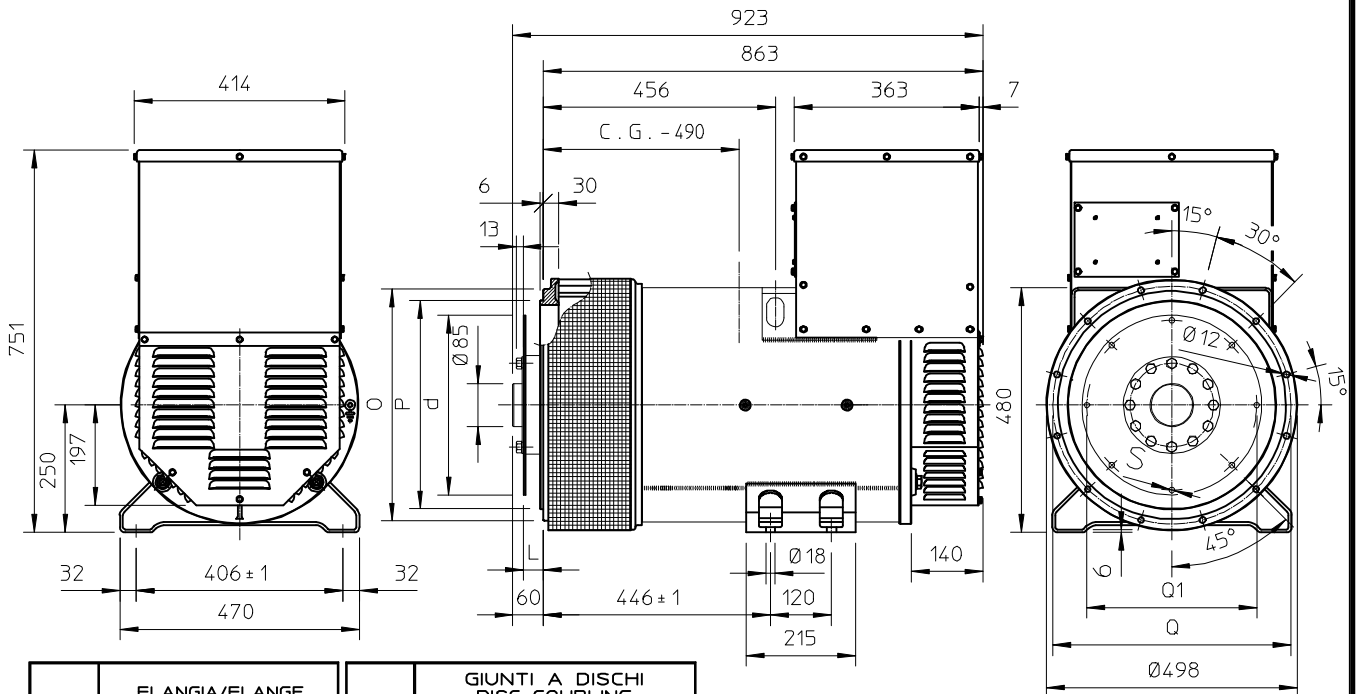

SAE N.	FLANGIA/FLANGE BRIDE/FLANSCH				SAE N.	GIUNTI A DISCHI DISC COUPLING DISQUE DE MONOPALIER SCHEIBENKUPPLUNG				
	O	P	Q	N. f.ori		L	d	Q1	N. f.ori	S
3	451	409,6	428,6	12	10	53,8	314,32	295,27	8	11
2	489	447,7	466,7	12	11 1/2	39,6	352,42	333,37	8	11
1	552	511,2	530,2	12	14	25,4	466,72	438,15	8	14

CG = GRAVITY CENTER

Electrical Characteristics										
Frequency	Hz	50				60				
Voltage (series star)	V	380	400	415	440	415	440	460	480	
Rated power class H	kVA	150	150	150	125	150	170	180	180	
	kW	120	120	120	100	120	136	144	144	
Rated power class F	kVA	136	136	136	113	132	150	163	163	
	kW	109	109	109	90,4	106	120	130	130	
Regulation with UVR6		±1% with any power factor and speed variations between -5% +30%								
Insulation class		H								
Execution		Brushless								
Stator winding		12 ends								
Rotor		with damping cage								
Efficiencies class H	4/4	%	93,1	93,2	92,9	92,7	94,3	94,8	94,9	95
(see graph. for details)	3/4	%	93,2	93,5	93,4	93,1	94,7	94,9	95	95,2
	2/4	%	91,9	92	92	91,8	93,5	93,6	93,7	93,8
	1/4	%	89,2	89	88,8	88,8	90,2	90,2	90,2	90
Reactances (f. l.cl. F)	Xd	%	265,9	240	223,0	165,3	267,6	269,8	261,3	240
	Xd'	%	16,4	14,8	13,7	10,2	16,5	16,6	16,1	14,8
	Xd''	%	6,9	6,2	5,8	4,3	6,9	7,0	6,8	6,2
	Xq	%	135,3	122,1	113,4	84,1	136,1	137,2	132,9	122,1
	Xq'	%	135,3	122,1	113,4	84,1	136,1	137,2	132,9	122,1
	Xq''	%	29,4	26,5	24,6	18,3	29,5	29,8	28,9	26,5
	X ₂	%	18,3	16,5	15,3	11,4	18,4	18,5	18,0	16,5
	X ₀	%	2,8	2,5	2,3	1,7	2,8	2,8	2,7	2,5
Short Circuit Ratio	Kcc		0,40	0,48	0,55	0,91	0,30	0,35	0,40	0,48
Time Constants	Td'	sec.	0,0401							
	Td''	sec.	0,0095							
	Tdo'	sec.	1,90							
	Tα	sec.	0,017							
Short Circuit Current Capacity		%	>300				>350			
Excitation at no load	Amp.		0,3	0,4	0,5	0,7	0,2	0,3	0,4	0,5
Excitation at full load	Amp.		2,3	2,4	2,5	2,7	2,1	2,3	2,4	2,6
Overload (long-term)		%	1 hour in a 6 hours period 110% rated load							
Overload per 20 sec.		%	300							
Stator Winding Resistance (20°C)	Ω		0,015							
Rotor Winding Resistance (20°C)	Ω		3,577							
Exciter Resistance (20 °C)	Ω		Rotor : 0,410				Stator : 15,28			
Heat dissipation at f.l.cl.H	W		8894	8755	9171	7875	7253	7460	7739	7579
Telephone Interference			FHT < 2%				TIF < 40			
Radio interference			EN50081-1; EN50082-1; VDE0875K. For others standards apply to factory							
Waveform Distors.(THD) at f. load	LL/LN %		1,7 / 1,8							
Waveform Distors.(THD) at no load	LL/LN %		2,3 / 2,4							
Mechanical characteristics										
Protection			IP 21 (other protection on request)							
DE bearing			6314.2RS							
NDE bearing			6311.2RS							
Weight of wound stator assembly	kg		168							
Weight of wound rotor assembly	kg		106							
Weight of complete generator	kg		465							
Maximun overspeed	rpm		2250							
Unbalanced magnetic pull at f.l.cl.F	kN/mm		5,6							
Cooling air requirement	m ³ /min		19,3				23			
Inertia Constant (H)	sec.		0,098				0,117			
Noise level at 1m/7m	dB(A)		79 / 65				83 / 69			

This document is a propriety of Mecc Alte S.p.a..All rights reserved.

50 Hz

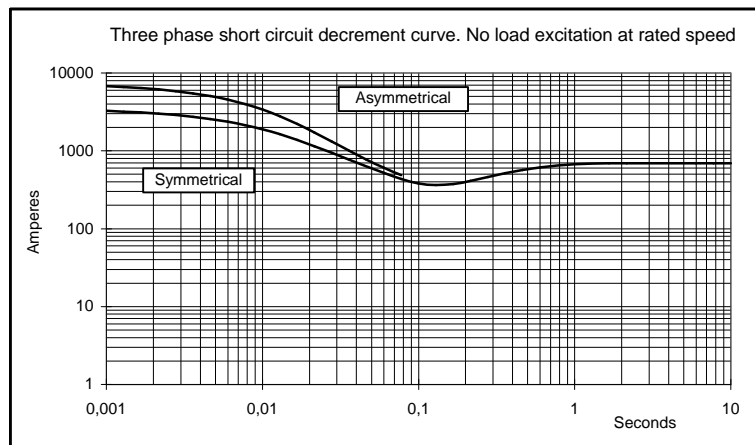
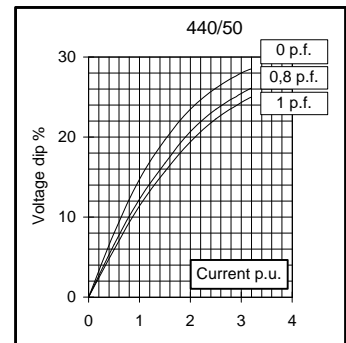
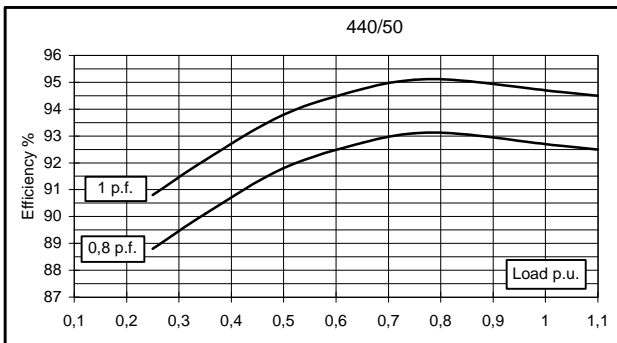
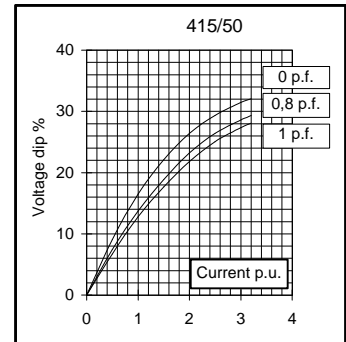
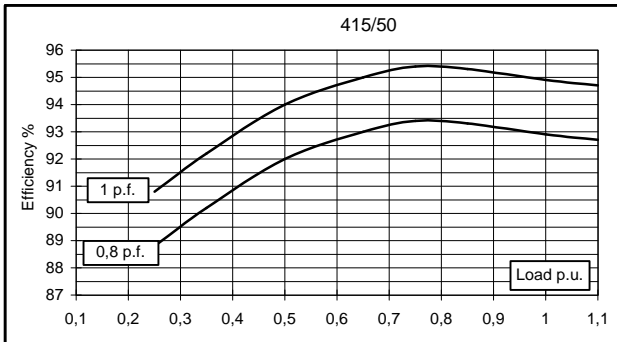
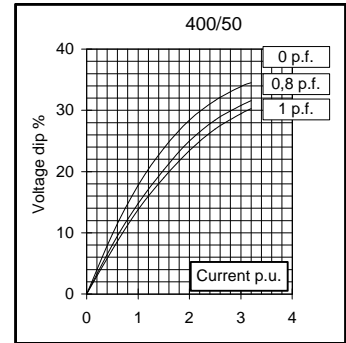
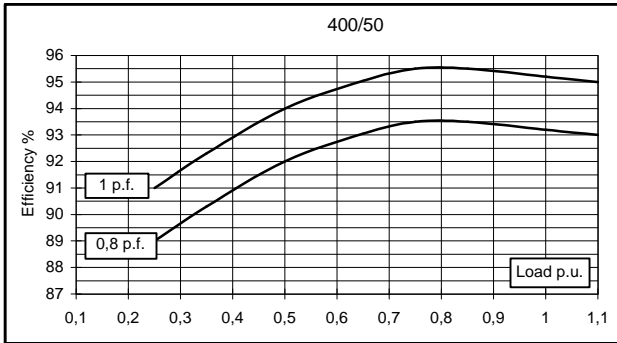
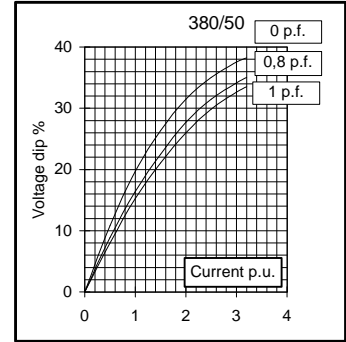
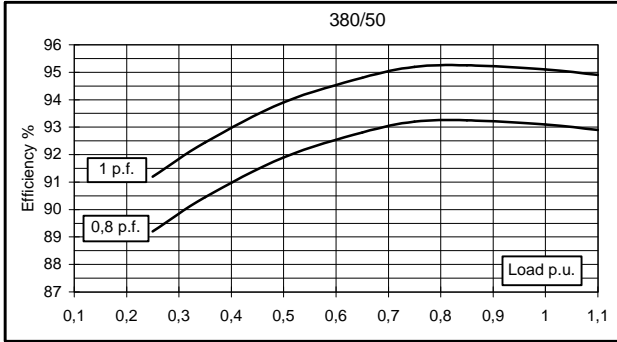

This document is a propriety of Mecc Alte S.p.a.. All rights reserved.

60 Hz

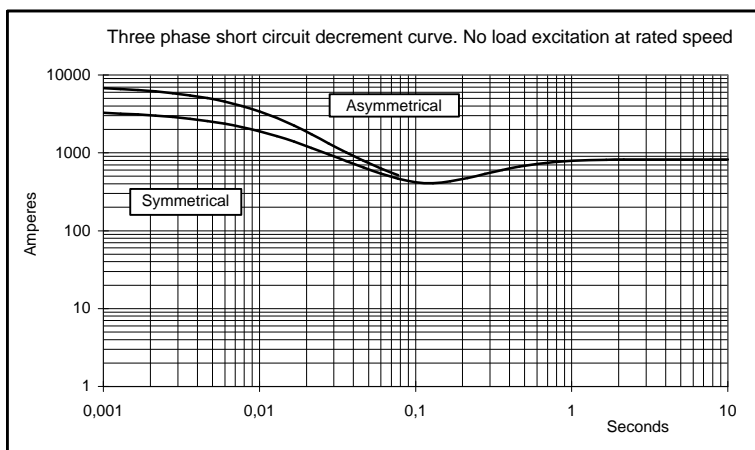
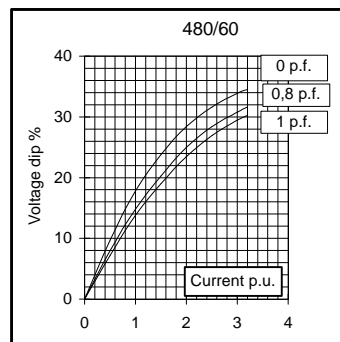
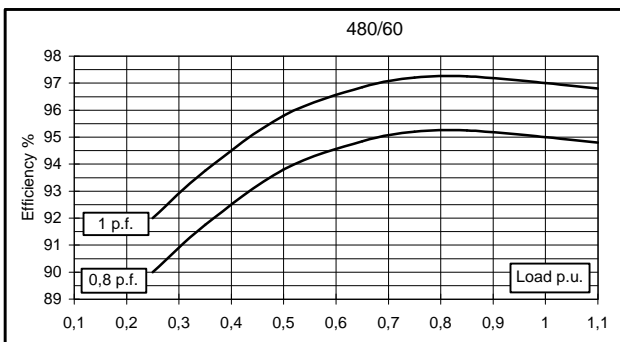
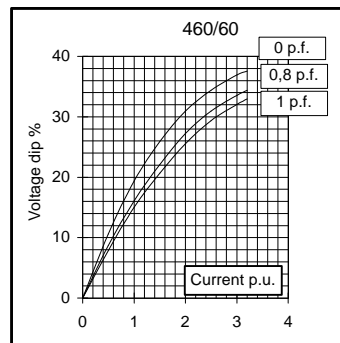
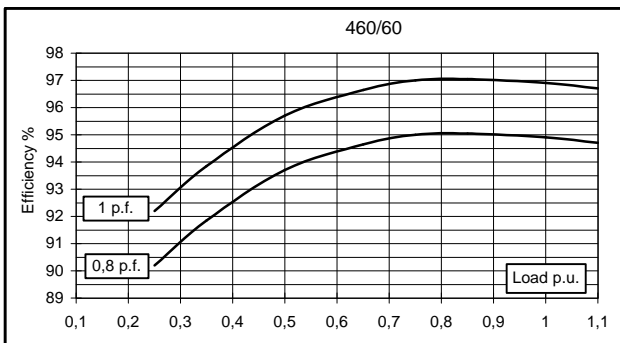
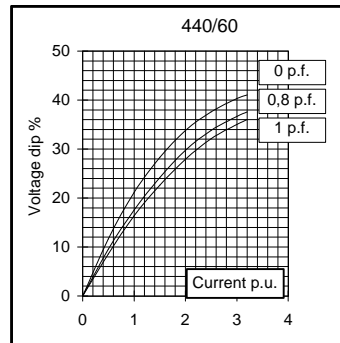
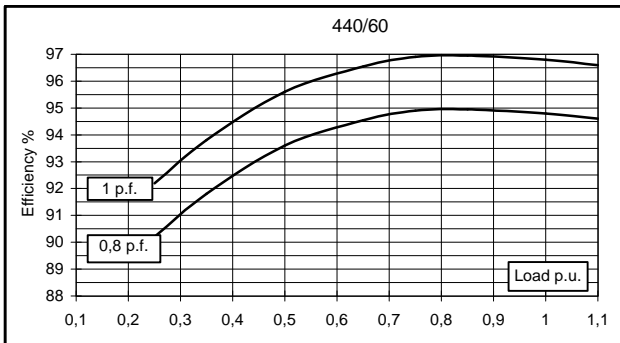
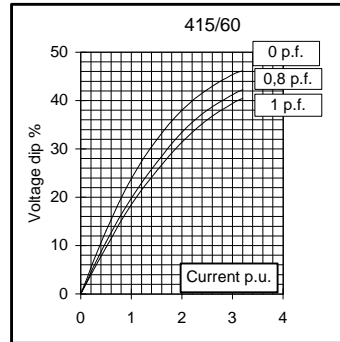
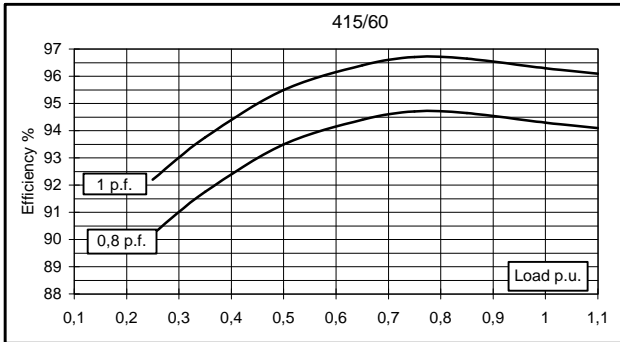

This document is a propriety of Mecc Alte S.p.a.. All rights reserved.

TWO BEARING MOMENTS OF INERTIA

FAMCO
هایپر صنعت

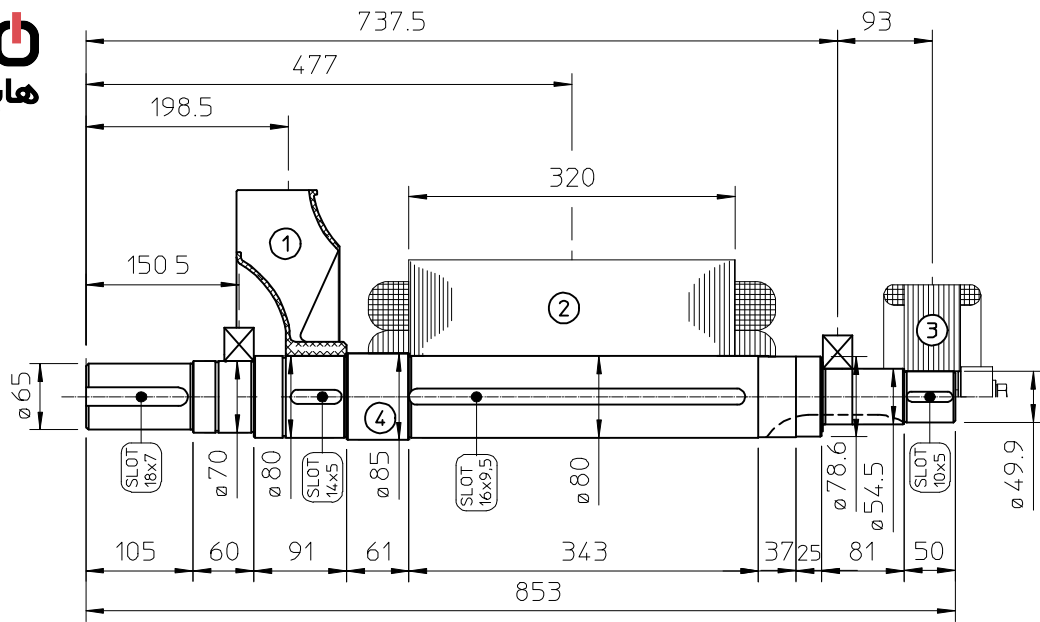

COMPONENT	WEIGHT kg	J kgm ²
1 FAN	3,3	0,0451
2 MAIN ROTOR	106	1.0320
3 EX. ROTOR	14,5	0,0874
4 SHAFT	28.1	0.0211
TOTAL	151.9	1.1856

TWO BEARING DIMENSIONS

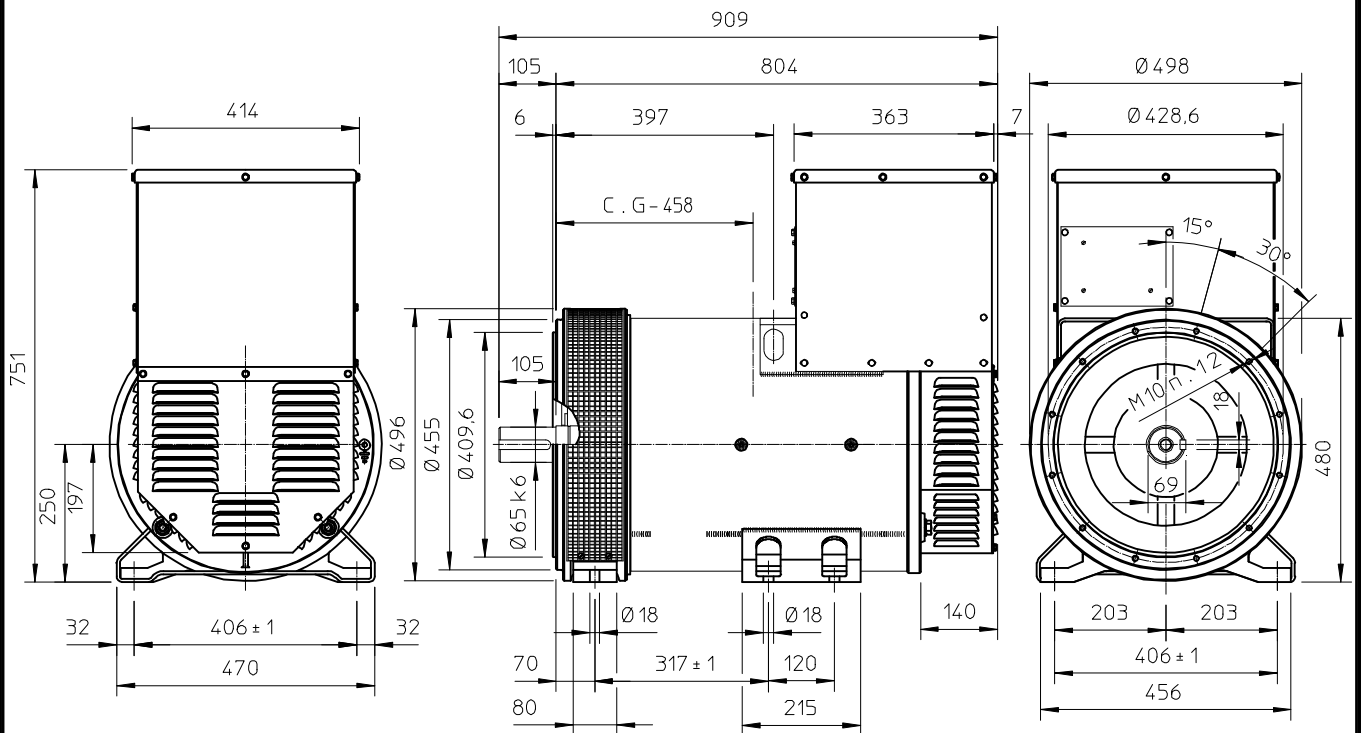

C.G. = GRAVITY CENTER

SINGLE BEARING MOMENTS OF INERTIA

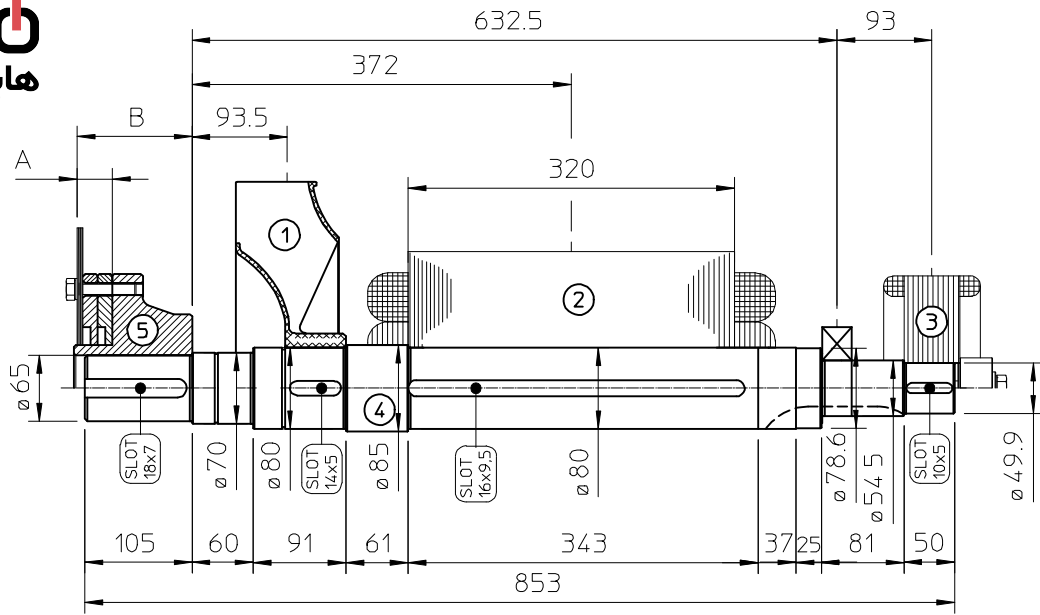

COMPONENT	WEIGHT kg	J kgm ²
1 FAN	3,3	0,0451
2 MAIN ROTOR	106	1,0320
3 EX ROTOR	14,5	0,0874
4 SHAFT	28,1	0,0211
TOTAL	151,9	1,1856

SAE No	SHAFTS COUPLING FLEX PLATE			
	A	B	WEIGHT kg	J kgm ²
10	46,5	112,8	20,5	0,1342
11,5	37,3	98,6	19,3	0,1512
14	27,4	84,4	21,1	0,2752

SINGLE BEARING DIMENSIONS

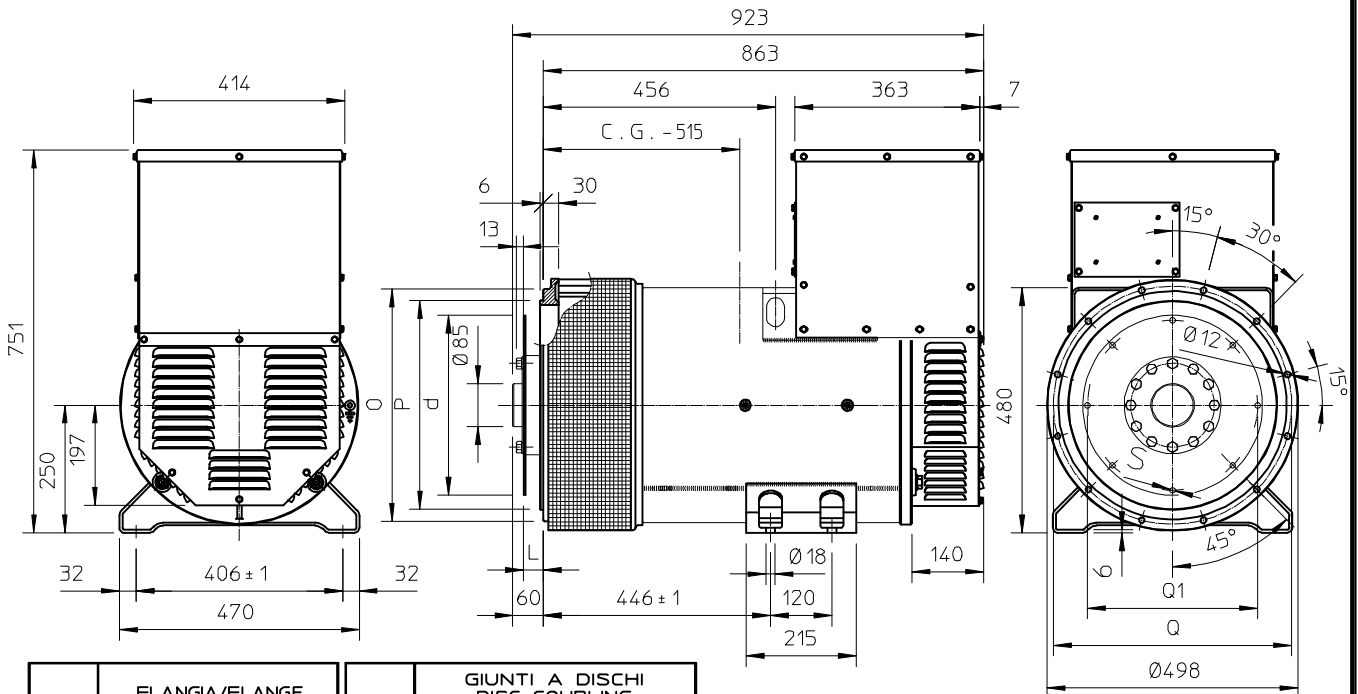

SAE N.	FLANGIA/FLANGE BRIDE/FLANSCH				SAE N.	GIUNTI A DISCHI DISC COUPLING DISQUE DE MONOPALIER SCHEIBENKUPPLUNG				
	O	P	Q	N. fori		L	d	Q1	N. fori	S
3	451	409,6	428,6	12	10	53,8	314,32	295,27	8	11
2	489	447,7	466,7	12	11 1/2	39,6	352,42	333,37	8	11
1	552	511,2	530,2	12	14	25,4	466,72	438,15	8	14

CG = GRAVITY CENTER

Electrical Characteristics										
Frequency	Hz	50				60				
Voltage (series star)	V	380	400	415	440	415	440	460	480	
Rated power class H	kVA	180	180	180	165	210	220	220	220	
	kW	144	144	144	132	168	176	176	176	
Rated power class F	kVA	170	170	170	155	195	205	205	205	
	kW	136	136	136	124	156	164	164	164	
Regulation with UVR6		±1 % with any power factor and speed variations between -5% +30%								
Insulation class		H								
Execution		Brushless								
Stator winding		12 ends								
Rotor		with damping cage								
Efficiencies class H	4/4	%	92,4	92,5	92,2	92	92,8	93,3	93,4	93,5
(see graph. for details)	3/4	%	92,4	92,7	92,6	92,3	93,1	93,3	93,5	93,7
	2/4	%	91,3	91,4	91,4	91,2	92,1	92,2	92,3	92,4
	1/4	%	89,2	89	88,8	88,6	90,2	90,2	90,2	90
Reactances (f. l.cl. F)	Xd	%	229,4	207	192,3	156,8	264,3	246,3	225,4	207
	Xd'	%	11,3	10,2	9,5	7,7	13,0	12,1	11,1	10,2
	Xd''	%	6,4	5,8	5,4	4,4	7,4	6,9	6,3	5,8
	Xq	%	113,0	102	94,8	77,3	130,3	121,4	111,1	102
	Xq'	%	113,0	102	94,8	77,3	130,3	121,4	111,1	102
	Xq''	%	22,9	20,7	19,2	15,7	26,4	24,6	22,5	20,7
	X ₂	%	15,0	13,5	12,5	10,2	17,2	16,1	14,7	13,5
	X ₀	%	3,1	2,8	2,6	2,1	3,6	3,3	3,0	2,8
Short Circuit Ratio	Kcc		0,39	0,42	0,60	0,97	0,28	0,35	0,39	0,42
Time Constants	Td'	sec.	0,075							
	Td''	sec.	0,012							
	Tdo'	sec.	0,80							
	Tα	sec.	0,016							
Short Circuit Current Capacity		%	>300				>350			
Excitation at no load	Amp.		0,65	0,7	0,8	1,1	0,35	0,5	0,6	0,65
Excitation at full load	Amp.		2,9	3,1	3,4	3,5	2,5	2,7	2,8	3
Overload (long-term)		%	1 hour in a 6 hours period 110% rated load							
Overload per 20 sec.		%	300							
Stator Winding Resistance (20°C)	Ω		0,0134							
Rotor Winding Resistance (20°C)	Ω		4,510							
Exciter Resistance (20 °C)	Ω		Rotor : 0,685				Stator : 15,28			
Heat dissipation at f.l.cl.H	W		11844	11676	12182	11478	13034	12639	12437	12235
Telephone Interference			FHT < 2%				TIF < 40			
Radio interference			EN50081-1, EN50082-1, VDE0875K. For others standards apply to factory							
Waveform Distors.(THD) at f. load	LL/LN %		2,8 / 2,7							
Waveform Distors.(THD) at no load	LL/LN %		3,1 / 3							
Mechanical characteristics										
Protection			IP 21 (other protection on request)							
DE bearing			6318.2RS							
NDE bearing			6314.2RS							
Weight of wound stator assembly	kg		177							
Weight of wound rotor assembly	kg		109							
Weight of complete generator	kg		525							
Maximun overspeed	rpm		2250							
Unbalanced magnetic pull at f.l.cl.F	kN/mm		4,4							
Cooling air requirement	m ³ /min		32				39			
Inertia Constant (H)	sec.		0,122				0,144			
Noise level at 1m/7m	dB(A)		82 / 69				86 / 73			

All technical data are to be considered as a reference and they can be modified without any notice

This document is a propriety of Mecc Alte S.p.a..All rights reserved.

50 Hz

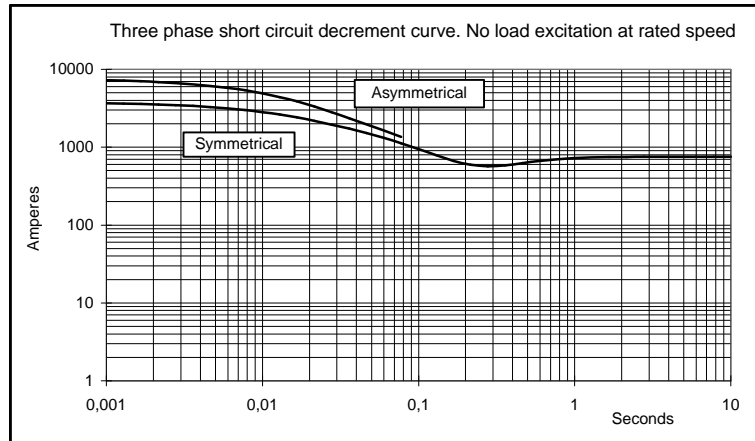
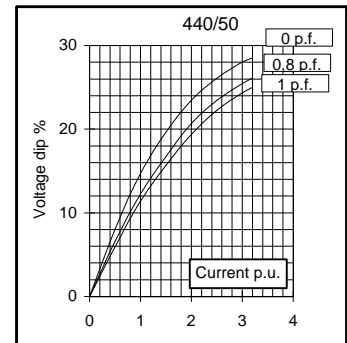
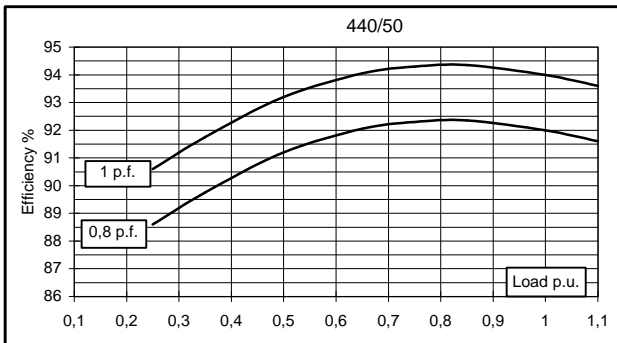
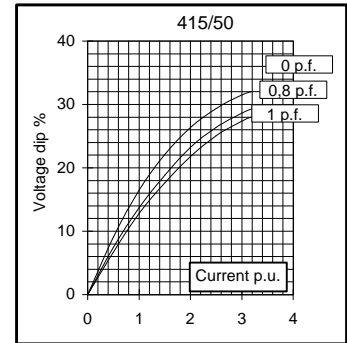
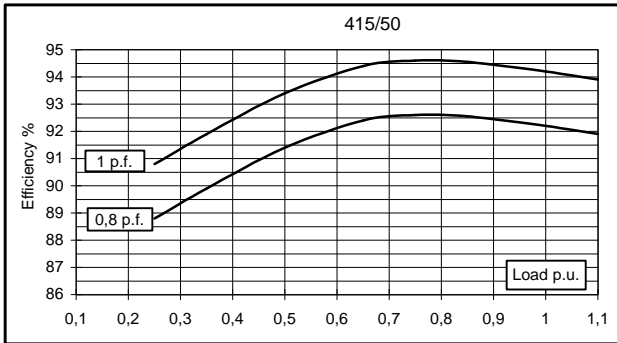
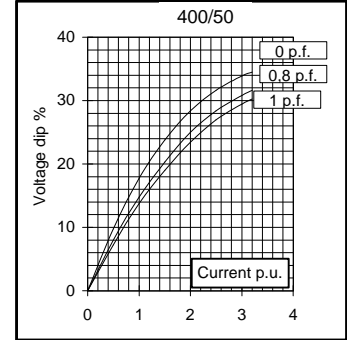
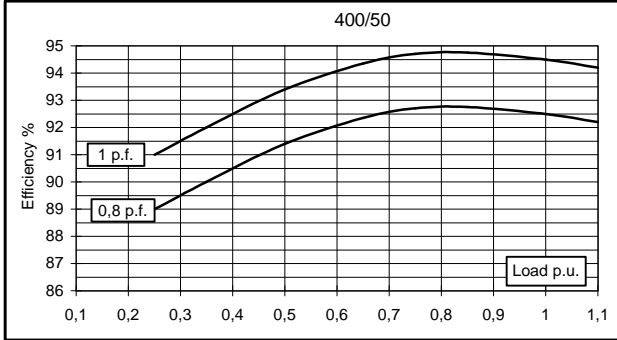
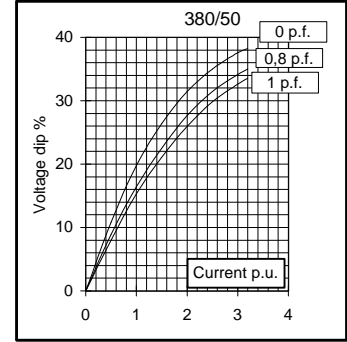
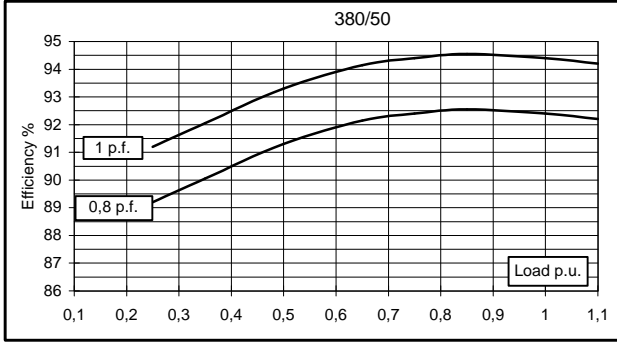

This document is a propriety of Mecc Alte S.p.a.. All rights reserved.

60 Hz

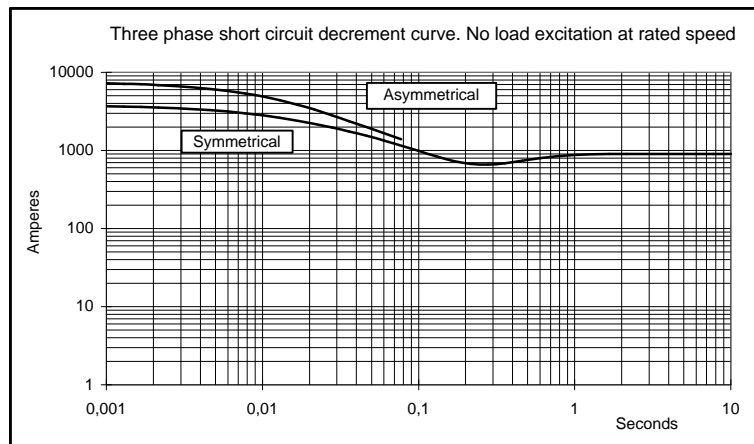
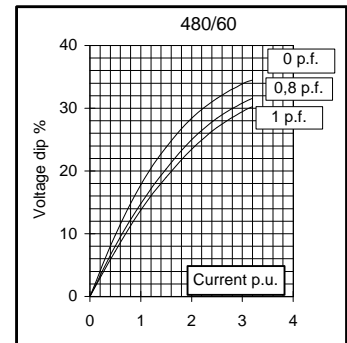
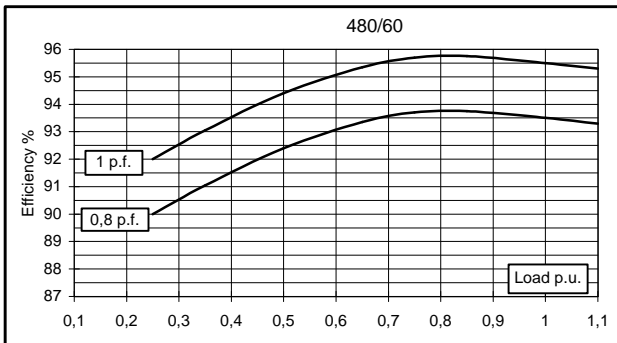
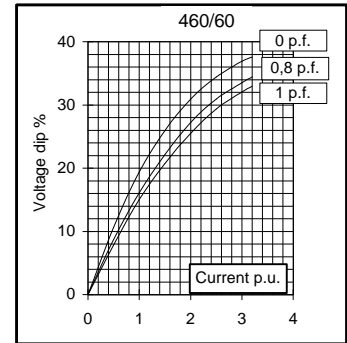
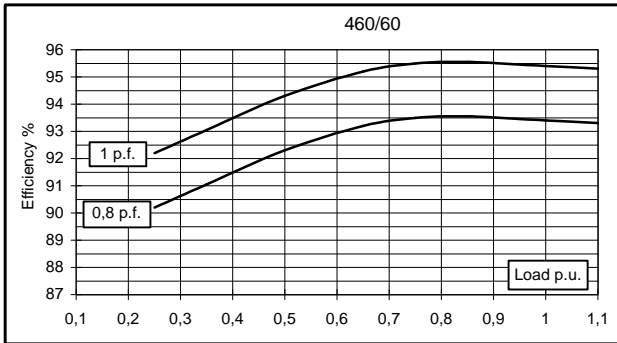
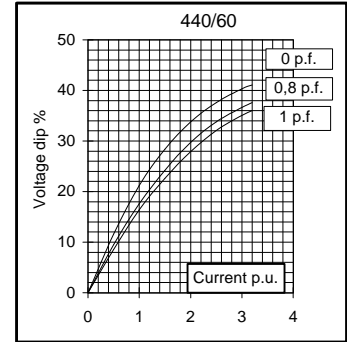
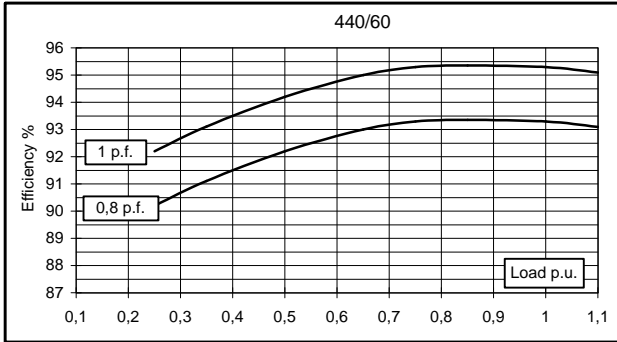
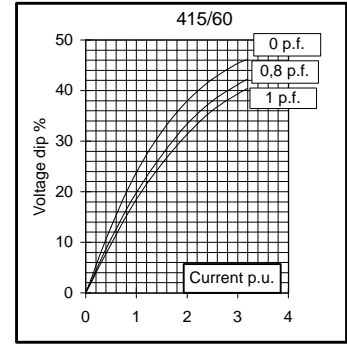
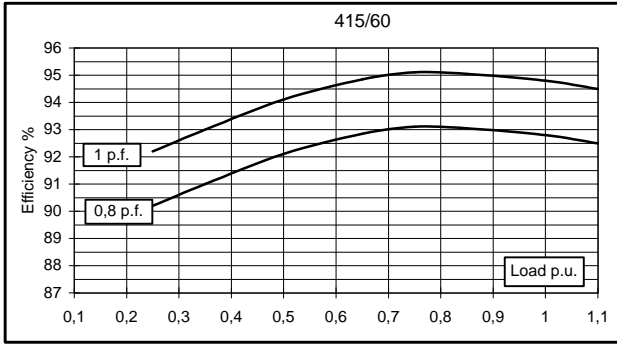

This document is a propriety of Mecc Alte S.p.a.. All rights reserved.

FAMCO
هایپر صنعت

TWO BEARING MOMENTS OF INERTIA

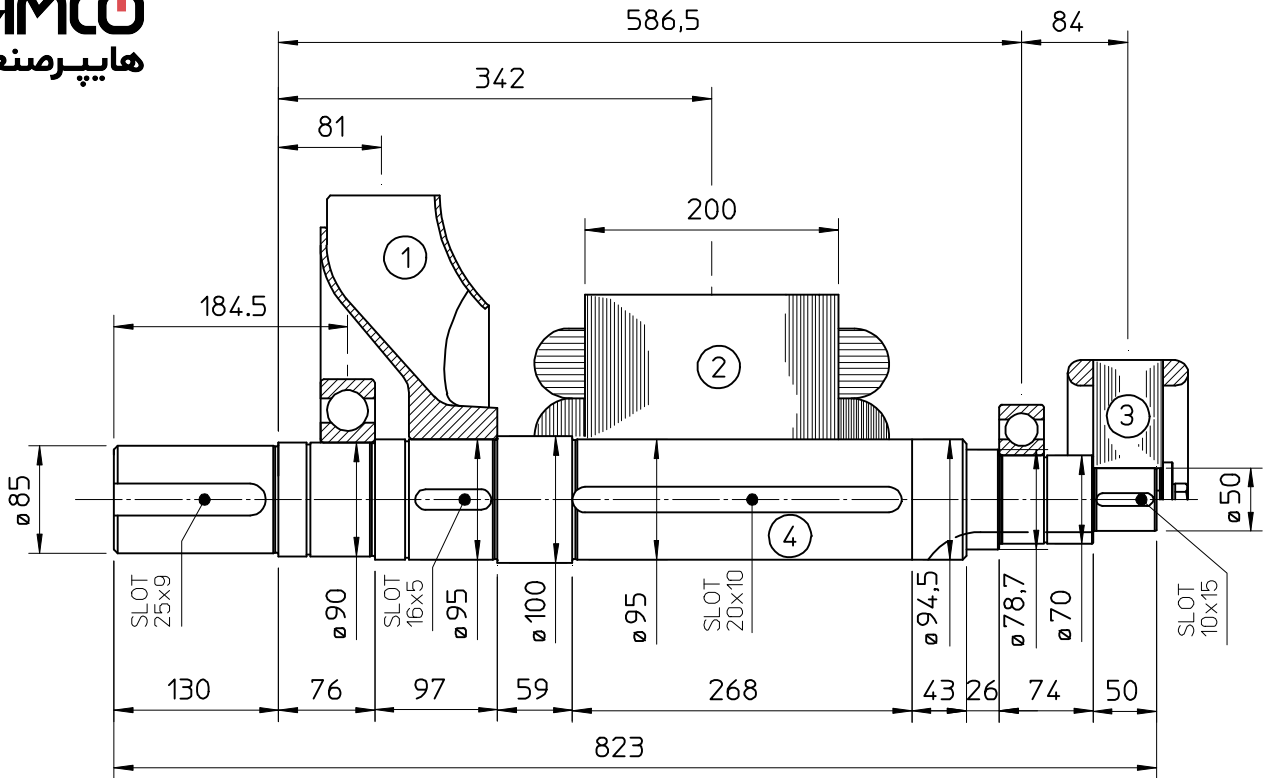

COMPONENT	WEIGHT kg	J kgm ²
1 FAN	6,1	0,1887
2 MAIN ROTOR	109	1,4587
3 EX. ROTOR	14,5	0,0874
4 SHAFT	38,5	0,0397
TOTAL	168,1	1,7745

TWO BEARING DIMENSIONS

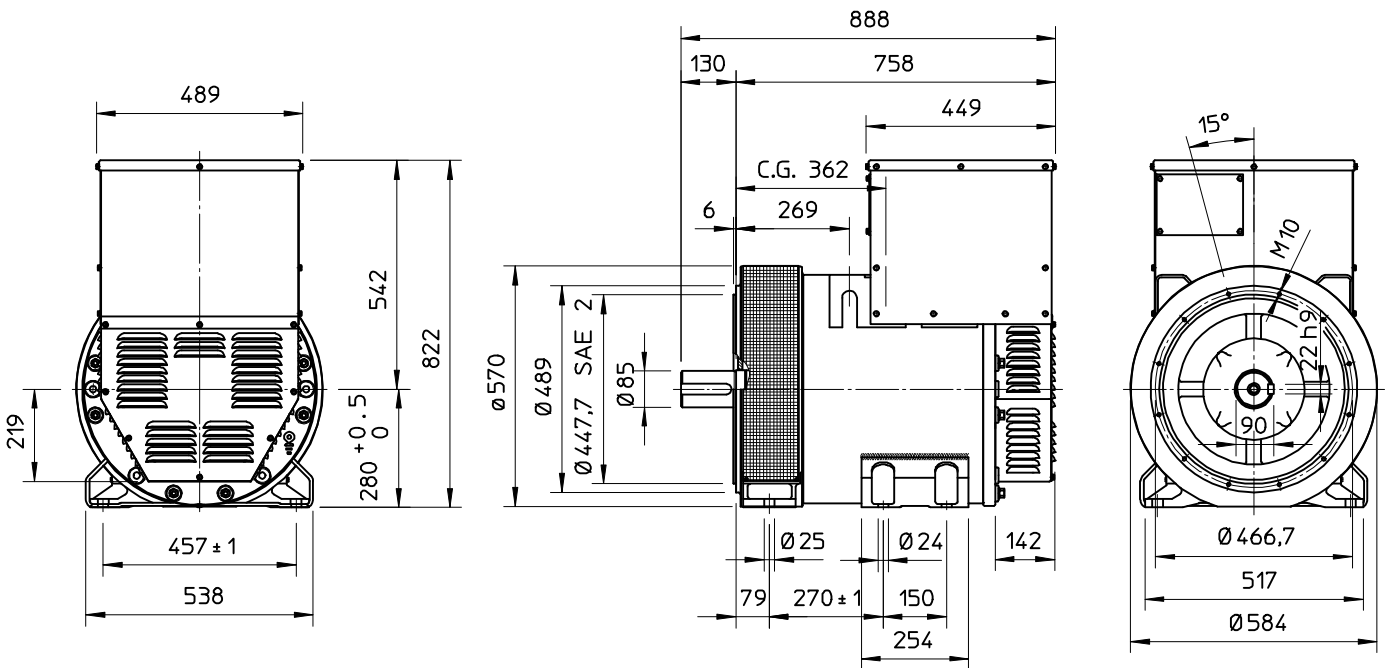

C.G = GRAVITY CENTER

SINGLE BEARING MOMENTS OF INERTIA

FAMCO
هاپیرمنعت

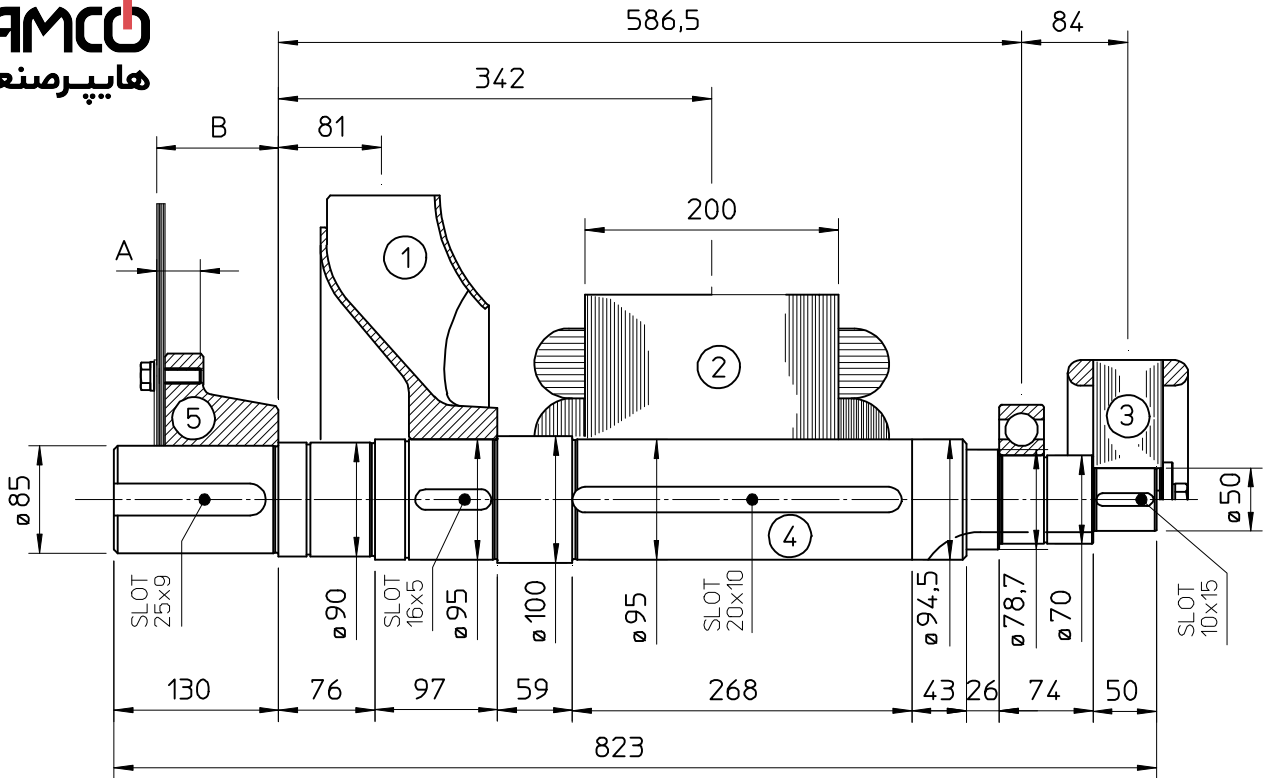

COMPONENT	WEIGHT kg	J kgm ²
1 FAN	6,1	0,1887
2 MAIN ROTOR	109	1,4587
3 EX. ROTOR	14,5	0,0874
4 SHAFT	38,5	0,0397
TOTAL	168,1	1,7745

SAE No	SHAFTS COUPLING FLEX PLATE			
	A	B	WEIGHT kg	J kgm ²
5				
11.5	41.1	110.4	22,7	0,306
14	34.7	96.4	22,7	0,306

SINGLE BEARING DIMENSIONS

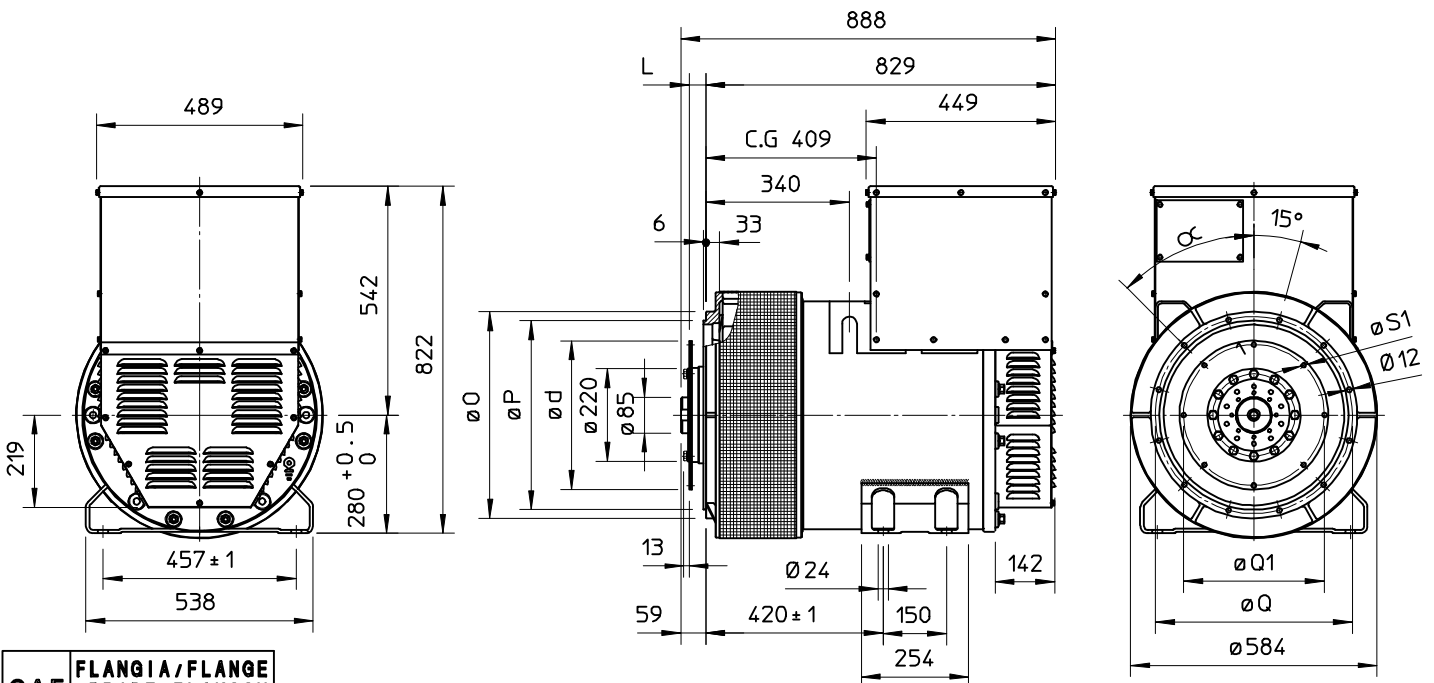

SAE N.	FLANGIA/FLANGE BRIDE/FLANSCH		
	O	P	Q
3	451	409,6	428,6
2	489	447,7	466,7
1	552	511,2	530,2
1/2	648	584,2	619,1

SAE N.	GIUNTI A DISCHI DISC COUPLING DISQUE DE MONOPALIER SCHEIBENKUPPLUNG					
	L	d	Q1	n. fori	S1	α
11 1/2	39,6	352,42	333,37	8	11	45°
14	25,4	466,72	438,15	8	14	45°

C.G = GRAVITY CENTER

Electrical Characteristics										
Frequency	Hz	50				60				
Voltage (series star)	V	380	400	415	440	415	440	460	480	
Rated power class H	kVA	200	200	200	190	230	240	240	240	
	kW	160	160	160	152	184	192	192	192	
Rated power class F	kVA	185	185	185	175	210	220	220	220	
	kW	148	148	148	140	168	176	176	176	
Regulation with UVR6		±1 % with any power factor and speed variations between -5% +30%								
Insulation class		H								
Execution		Brushless								
Stator winding		12 ends								
Rotor		with damping cage								
Efficiencies class H	4/4	%	92,7	92,8	92,5	92,3	93,2	93,7	93,8	93,9
(see graph. for details)	3/4	%	92,7	93	92,9	92,6	93,5	93,7	93,9	94,1
	2/4	%	91,7	91,8	91,8	91,6	92,6	92,7	92,8	92,9
	1/4	%	90,2	90	89,8	89,6	90,7	90,7	90,7	90,5
Reactances (f. l.cl. F)	Xd	%	232,7	210	195,1	164,9	269,2	249,9	228,7	210
	Xd'	%	12,7	11,5	10,7	9,0	14,7	13,7	12,5	11,5
	Xd''	%	6,9	6,2	5,8	4,9	7,9	7,4	6,8	6,2
	Xq	%	127,4	115	106,8	90,3	147,4	136,9	125,2	115
	Xq'	%	127,4	115	106,8	90,3	147,4	136,9	125,2	115
	Xq''	%	24,9	22,5	20,9	17,7	28,8	26,8	24,5	22,5
	X ₂	%	16,6	15,0	13,9	11,8	19,2	17,9	16,3	15,0
	X ₀	%	2,9	2,6	2,4	2,0	3,3	3,1	2,8	2,6
Short Circuit Ratio	Kcc		0,41	0,44	0,62	1,00	0,30	0,37	0,41	0,44
Time Constants	Td'	sec.	0,080							
	Td''	sec.	0,013							
	Tdo'	sec.	0,95							
	Tα	sec.	0,017							
Short Circuit Current Capacity		%	>300				>350			
Excitation at no load	Amp.		0,5	0,7	0,9	1,2	0,3	0,35	0,45	0,65
Excitation at full load	Amp.		2,9	3	3,2	3,4	2,4	2,6	2,8	2,9
Overload (long-term)		%	1 hour in a 6 hours period 110% rated load							
Overload per 20 sec.		%	300							
Stator Winding Resistance (20°C)	Ω		0,0108							
Rotor Winding Resistance (20°C)	Ω		4,485							
Exciter Resistance (20 °C)	Ω		Rotor : 0,685				Stator : 15,28			
Heat dissipation at f.l.cl.H	W		12600	12414	12973	12680	13425	12909	12691	12473
Telephone Interference			FHT < 2%				TIF < 40			
Radio interference			EN50081-1, EN50082-1, VDE0875K. For others standards apply to factory							
Waveform Distors.(THD) at f. load	LL/LN %		2,7 / 2,6							
Waveform Distors.(THD) at no load	LL/LN %		3 / 2,9							
Mechanical characteristics										
Protection			IP 21 (other protection on request)							
DE bearing			6318.2RS							
NDE bearing			6314.2RS							
Weight of wound stator assembly	kg		182							
Weight of wound rotor assembly	kg		118							
Weight of complete generator	kg		573							
Maximun overspeed	rpm		2250							
Unbalanced magnetic pull at f.l.cl.F	kN/mm		5,2							
Cooling air requirement	m ³ /min		32				39			
Inertia Constant (H)	sec.		0,118				0,141			
Noise level at 1m/7m	dB(A)		82 / 69				86 / 73			

All technical data are to be considered as a reference and they can be modified without any notice

This document is a propriety of Mecc Alte S.p.a..All rights reserved.

50 Hz

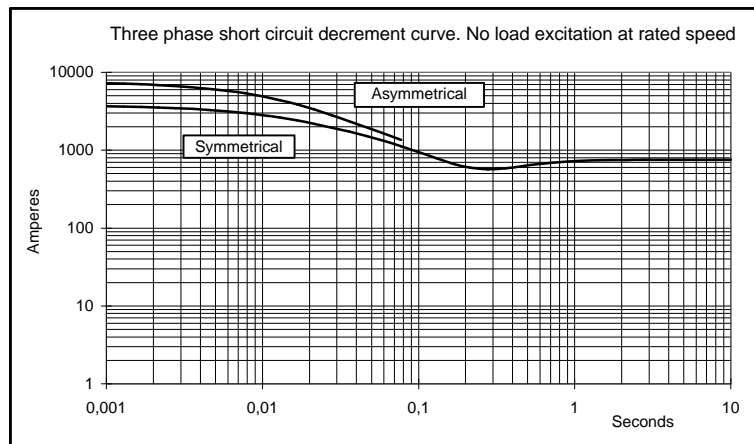
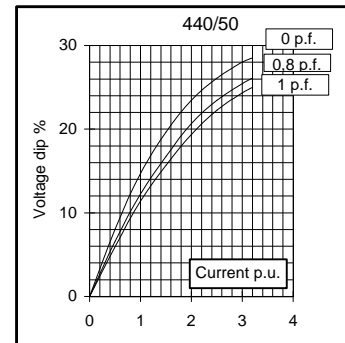
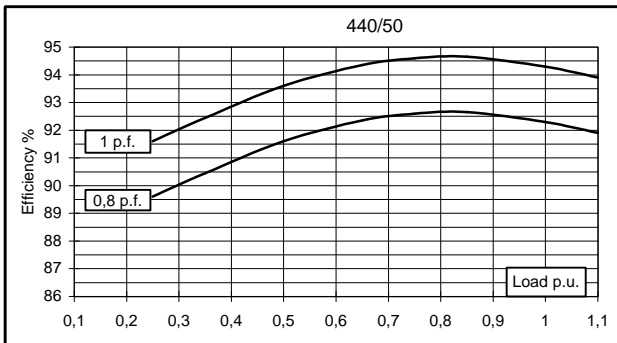
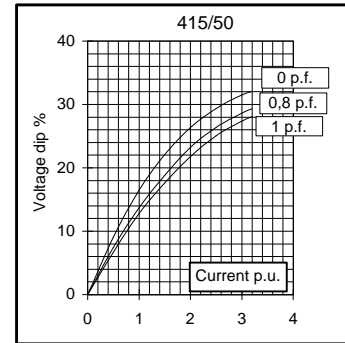
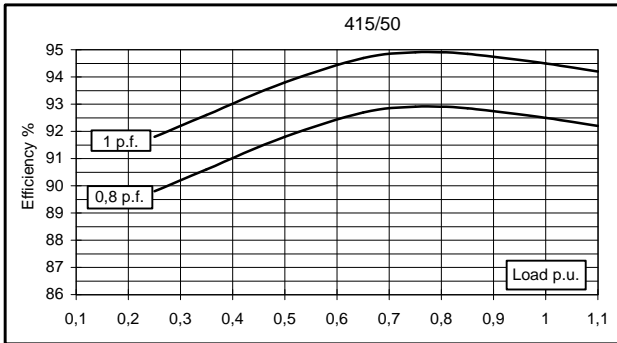
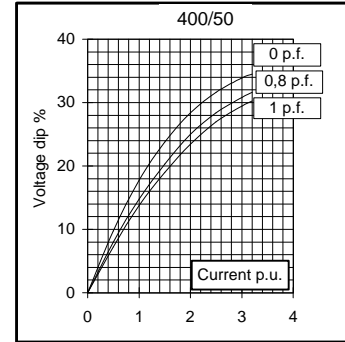
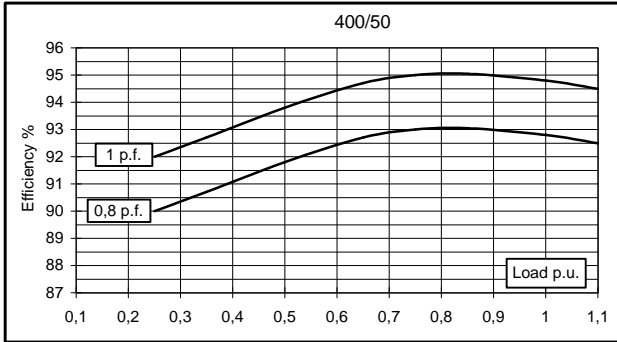
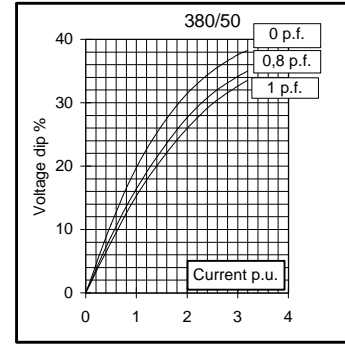
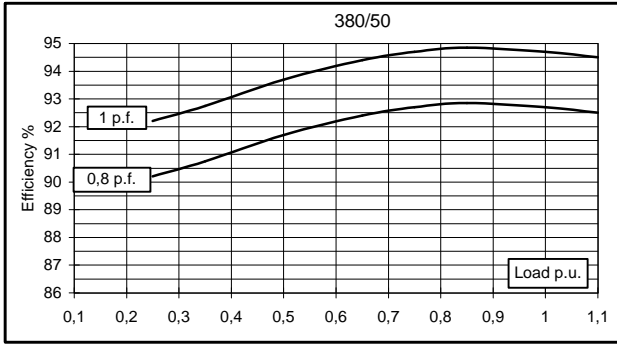

This document is a propriety of Mecc Alte S.p.a.. All rights reserved.

60 Hz

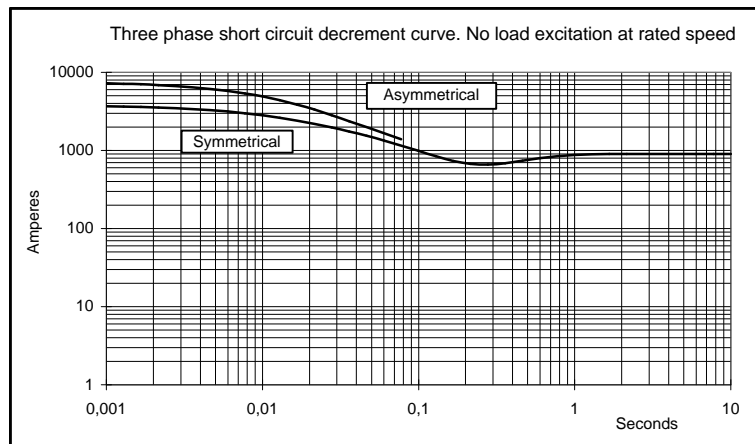
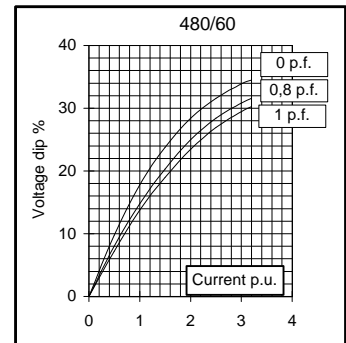
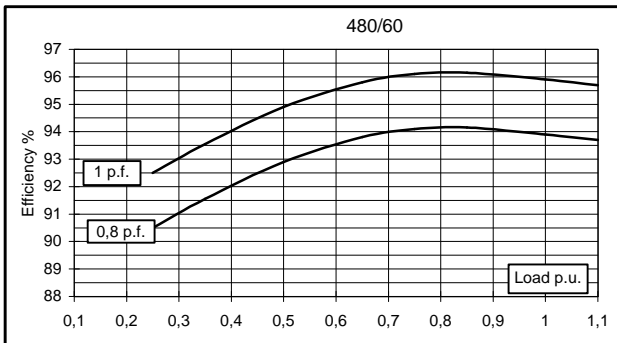
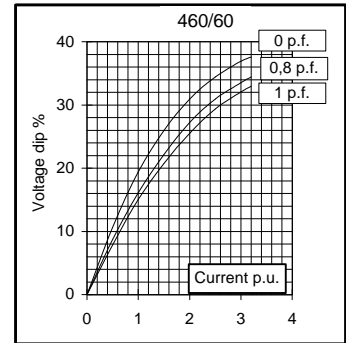
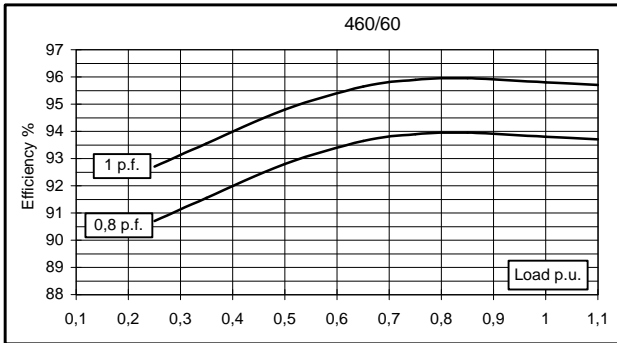
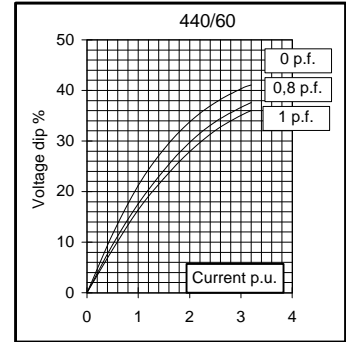
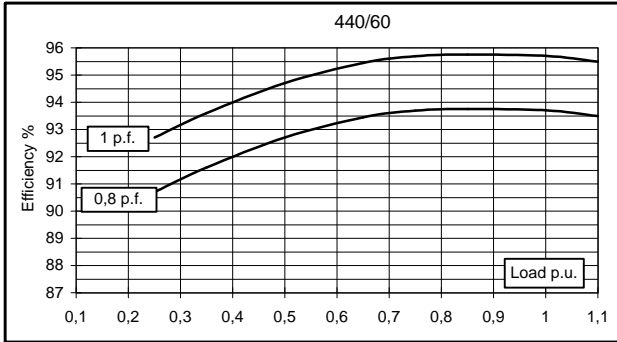
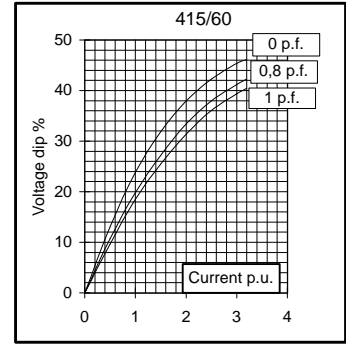
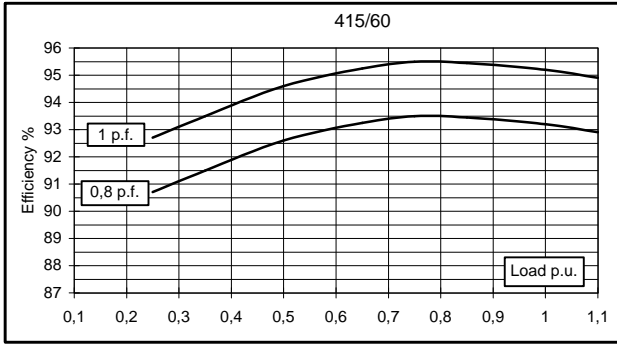

This document is a propriety of Mecc Alte S.p.a.. All rights reserved.

TWO BEARING MOMENTS OF INERTIA

FAMCO
هایپرمنت

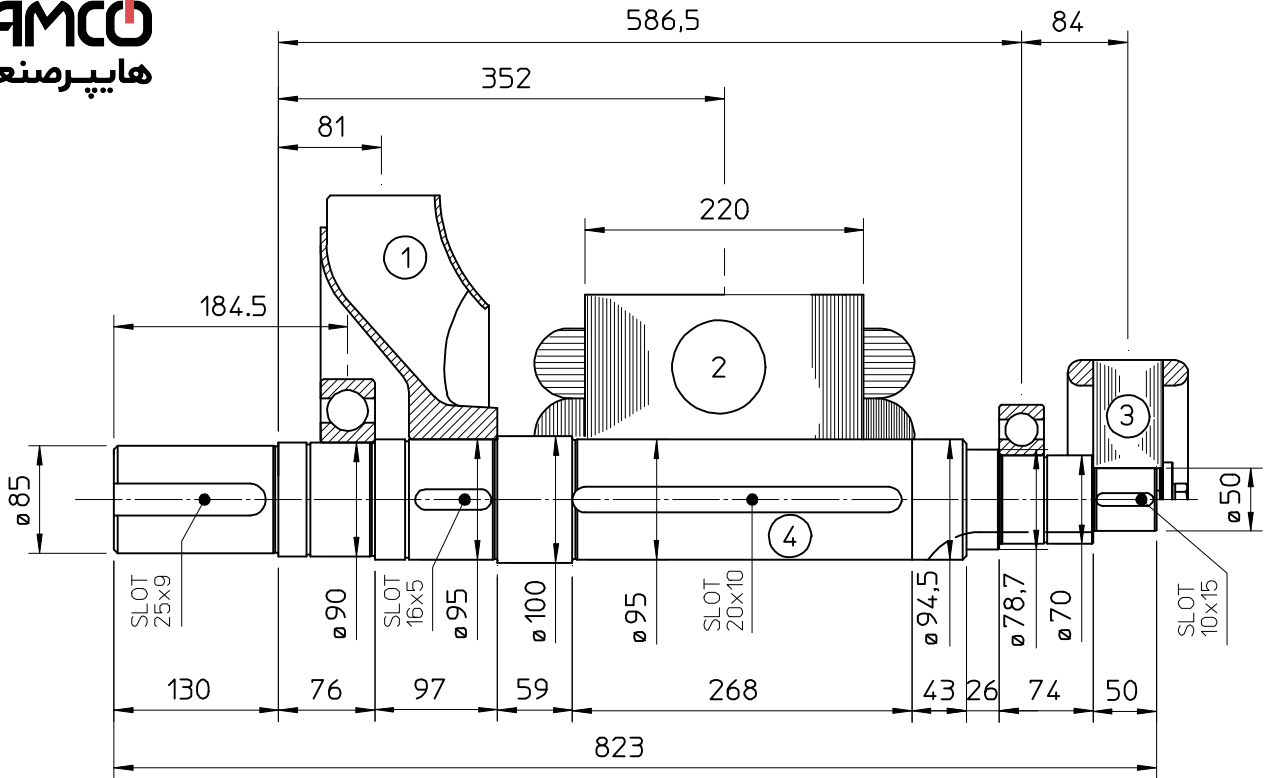

COMPONENT	WEIGHT kg	J kgm ²
1 FAN	6,1	0,1887
2 MAIN ROTOR	118	1,5878
3 EX. ROTOR	14,5	0,0874
4 SHAFT	38,5	0,0397
TOTAL	177,1	1,9036

FAMCO
هایپرمنت

TWO BEARING DIMENSIONS

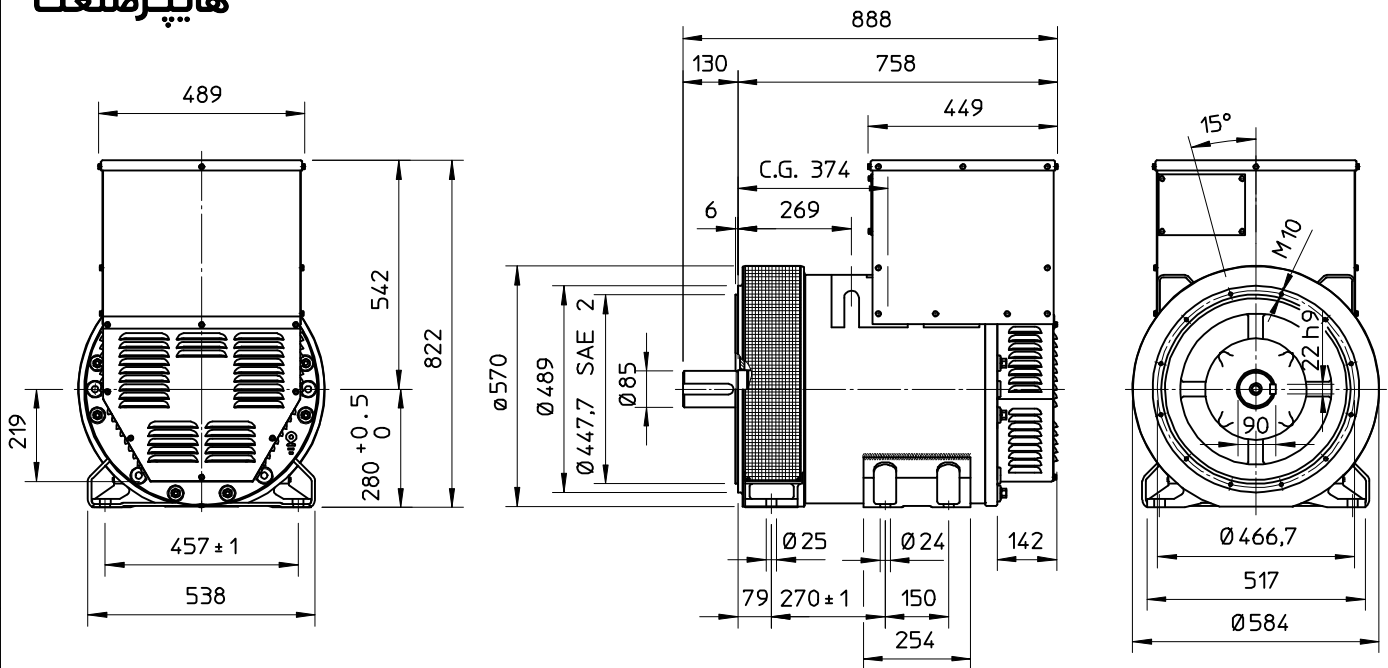

C. G = GRAVITY CENTER

SINGLE BEARING MOMENTS OF INERTIA

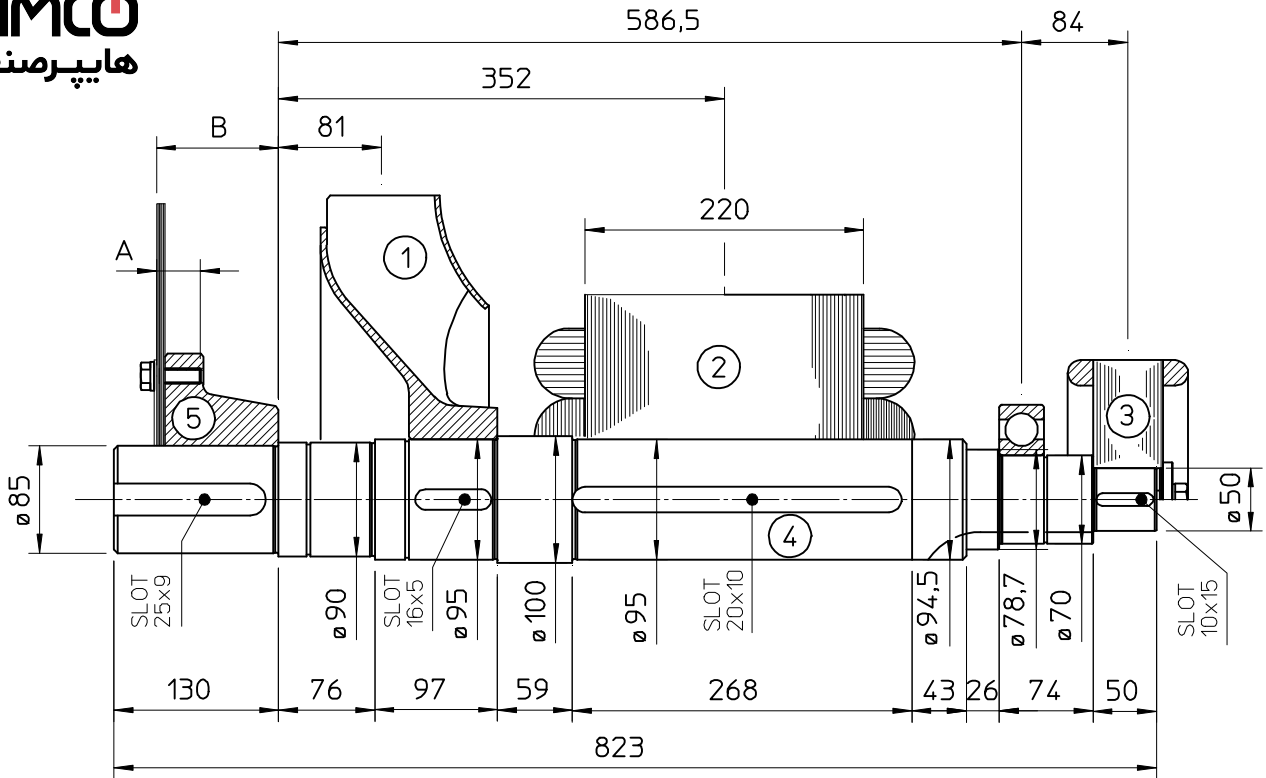

COMPONENT	WEIGHT kg	J kgm ²
1 FAN	6,1	0,1887
2 MAIN ROTOR	118	1,5878
3 EX. ROTOR	14,5	0,0874
4 SHAFT	38,5	0,0397
TOTAL	177,1	1,9036

SAE No	SHAFTS COUPLING FLEX PLATE			
	A	B	WEIGHT kg	J kgm ²
5				
11.5	41.1	110.4	22,7	0,306
14	34.7	96.4	22,7	0,306



SINGLE BEARING DIMENSIONS

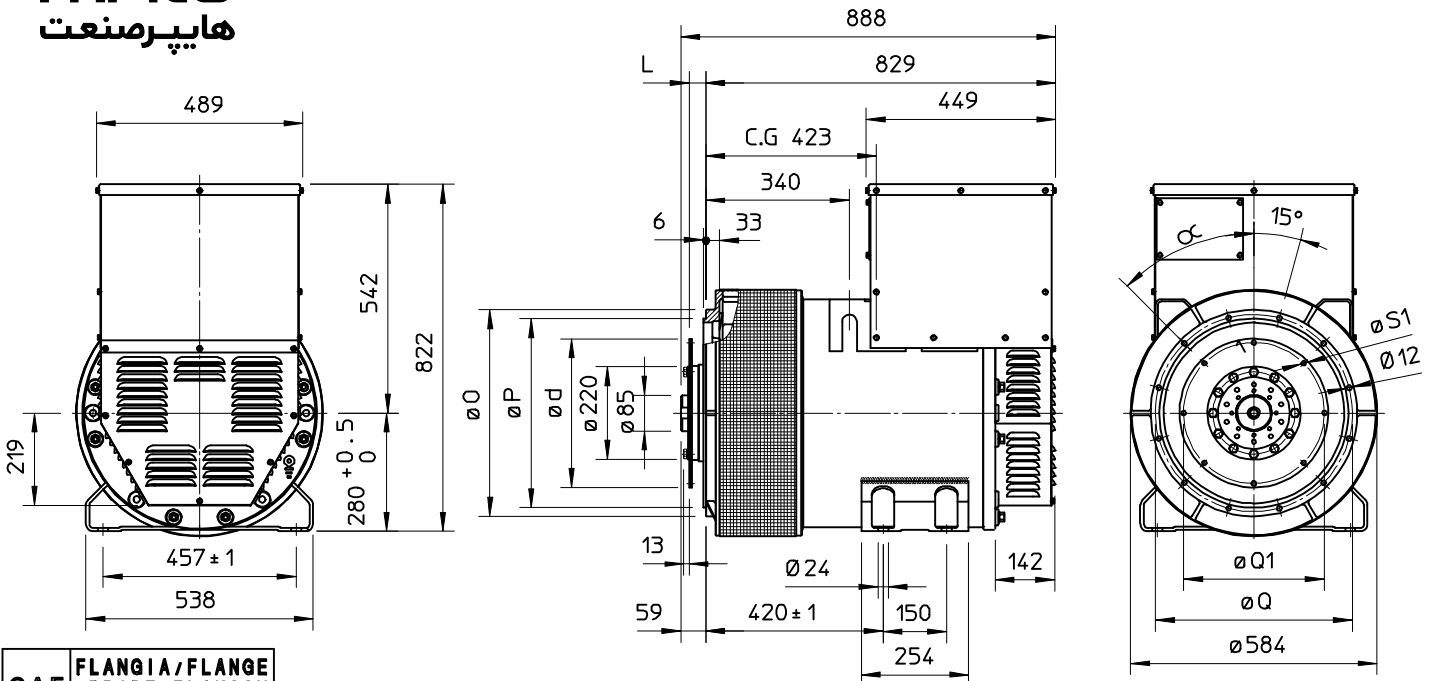

SAE N.	FLANGIA/FLANGE BRIDE/FLANSCH		
	O	P	Q
3	451	409,6	428,6
2	489	447,7	466,7
1	552	511,2	530,2
1/2	648	584,2	619,1

SAE N.	GIUNTI A DISCHI DISC COUPLING DISQUE DE MONOPALIER SCHEIBENKUPPLUNG					
	L	d	Q1	n. fori	S1	α1
11 1/2	39,6	352,42	333,37	8	11	45°
14	25,4	466,72	438,15	8	14	45°

C.G = GRAVITY CENTER

Electrical Characteristics										
Frequency	Hz	50				60				
Voltage (series star)	V	380	400	415	440	415	440	460	480	
Rated power class H	kVA	225	225	225	210	260	270	270	270	
	kW	180	180	180	168	208	216	216	216	
Rated power class F	kVA	207	207	207	190	240	250	250	250	
	kW	166	166	166	152	192	200	200	200	
Regulation with UVR6		±1 % with any power factor and speed variations between -5% +30%								
Insulation class		H								
Execution		Brushless								
Stator winding		12 ends								
Rotor		with damping cage								
Efficiencies class H	4/4	%	93	93,1	92,8	92,6	93,6	94,1	94,2	94,3
(see graph. for details)	3/4	%	93,1	93,4	93,3	93	94	94,2	94,4	94,6
	2/4	%	92	92,1	92,1	91,9	93,2	93,3	93,4	93,5
	1/4	%	89,7	89,5	89,3	89,1	90,7	90,7	90,7	90,5
Reactances (f. l.cl. F)	Xd	%	221,6	200	185,8	154,3	257,6	238,0	217,8	200
	Xd'	%	14,2	12,8	11,9	9,9	16,5	15,2	13,9	12,8
	Xd''	%	7,5	6,8	6,3	5,2	8,8	8,1	7,4	6,8
	Xq	%	121,9	110	102,2	84,8	141,7	130,9	119,8	110
	Xq'	%	121,9	110	102,2	84,8	141,7	130,9	119,8	110
	Xq''	%	25,6	23,1	21,5	17,8	29,8	27,5	25,2	23,1
	X ₂	%	17,7	16,0	14,9	12,3	20,6	19,0	17,4	16,0
	X ₀	%	3,0	2,7	2,5	2,1	3,5	3,2	2,9	2,7
Short Circuit Ratio	Kcc		0,40	0,43	0,65	1,10	0,30	0,35	0,40	0,43
Time Constants	Td'	sec.	0,085							
	Td''	sec.	0,0135							
	Tdo'	sec.	1,20							
	Tα	sec.	0,0185							
Short Circuit Current Capacity		%	>300				>350			
Excitation at no load	Amp.		0,55	0,67	0,8	1,1	0,3	0,4	0,5	0,65
Excitation at full load	Amp.		2,7	2,9	3,1	3,2	2,3	2,4	2,6	2,8
Overload (long-term)		%	1 hour in a 6 hours period 110% rated load							
Overload per 20 sec.		%	300							
Stator Winding Resistance (20°C)	Ω		0,0089							
Rotor Winding Resistance (20°C)	Ω		4,992							
Exciter Resistance (20 °C)	Ω		Rotor : 0,685				Stator : 15,28			
Heat dissipation at f.l.cl.H	W		13548	13340	13966	13425	14222	13543	13299	13056
Telephone Interference			FHT < 2%				TIF < 40			
Radio interference			EN50081-1, EN50082-1, VDE0875K. For others standards apply to factory							
Waveform Distors.(THD) at f. load	LL/LN %		2,8 / 2,9							
Waveform Distors.(THD) at no load	LL/LN %		2,6 / 2,8							
Mechanical characteristics										
Protection			IP 21 (other protection on request)							
DE bearing			6318.2RS							
NDE bearing			6314.2RS							
Weight of wound stator assembly	kg		201							
Weight of wound rotor assembly	kg		132,8							
Weight of complete generator	kg		602							
Maximun overspeed	rpm		2250							
Unbalanced magnetic pull at f.l.cl.F	kN/mm		5,7							
Cooling air requirement	m ³ /min		32				39			
Inertia Constant (H)	sec.		0,115				0,138			
Noise level at 1m/7m	dB(A)		82 / 69				86 / 73			

All technical data are to be considered as a reference and they can be modified without any notice

This document is a propriety of Mecc Alte S.p.a..All rights reserved.

50 Hz

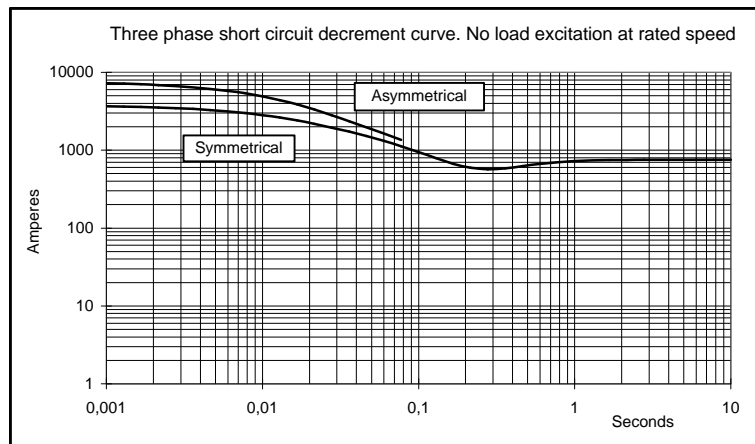
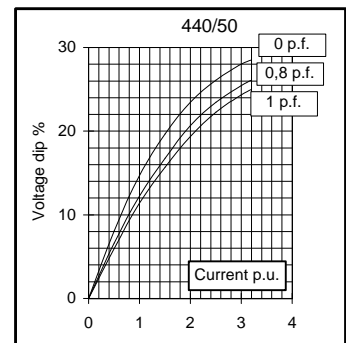
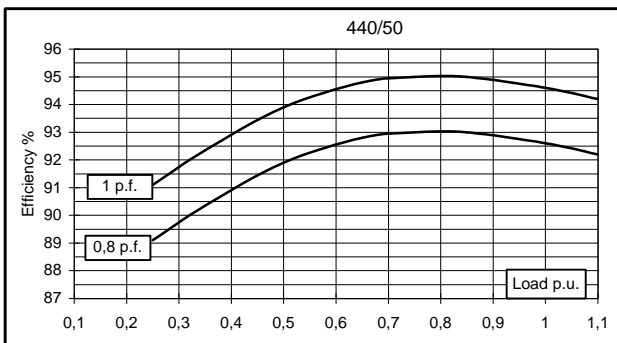
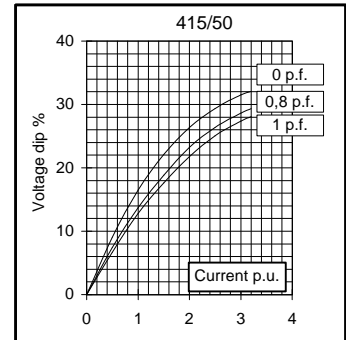
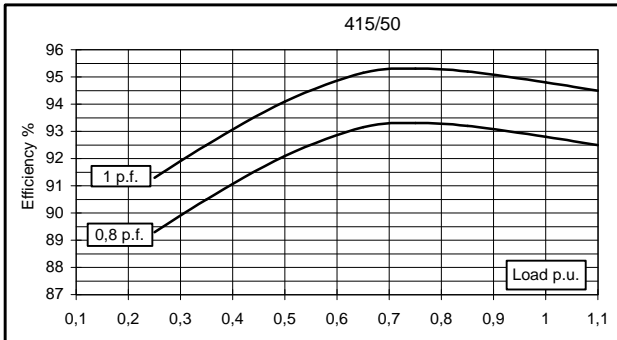
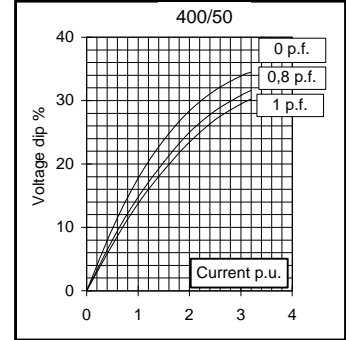
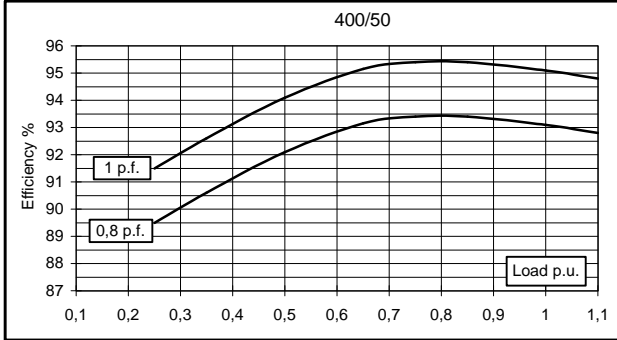
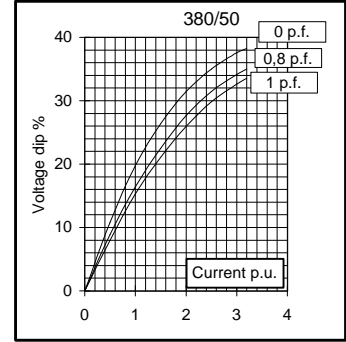
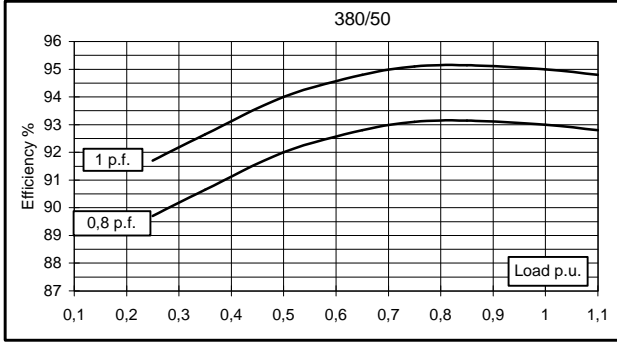

This document is a propriety of Mecc Alte S.p.a.. All rights reserved.

60 Hz

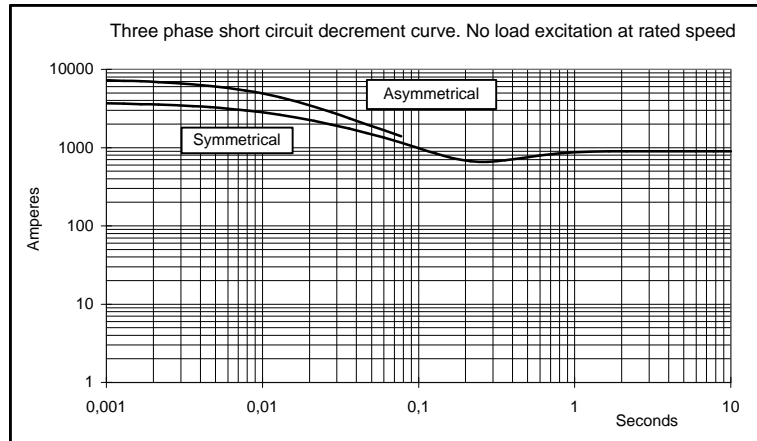
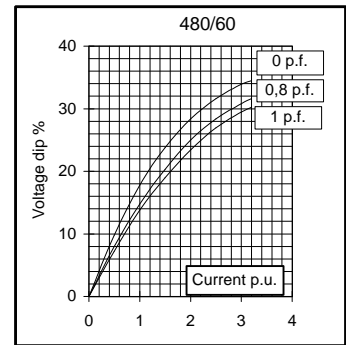
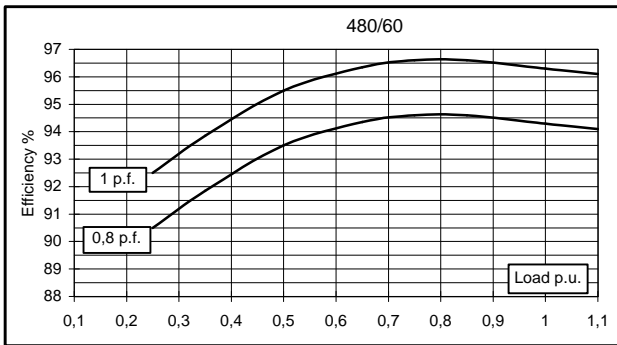
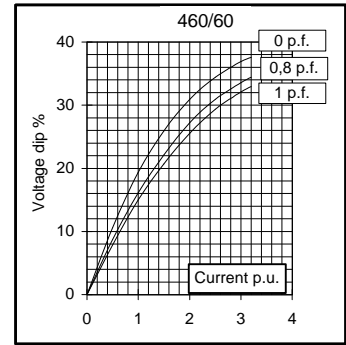
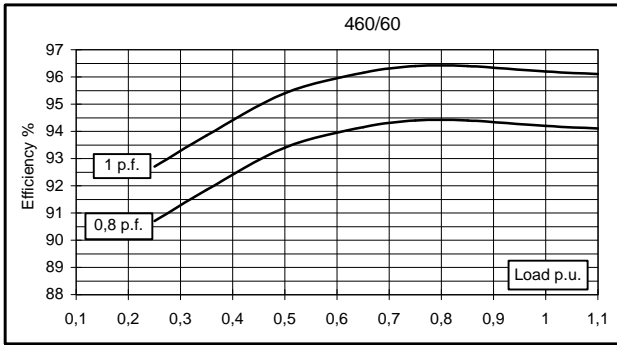
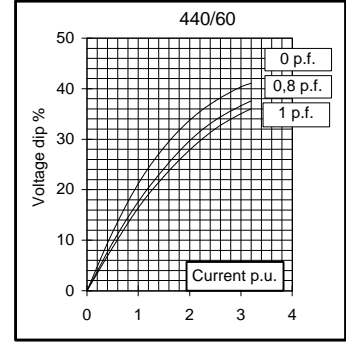
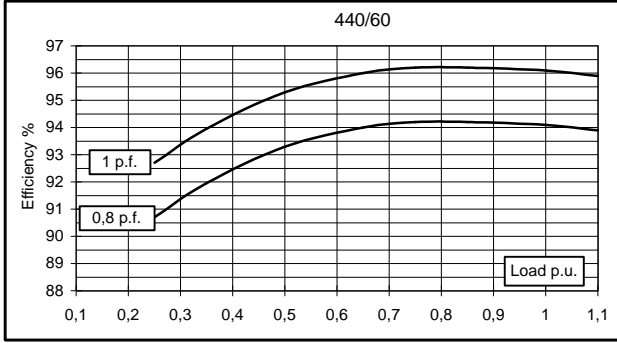
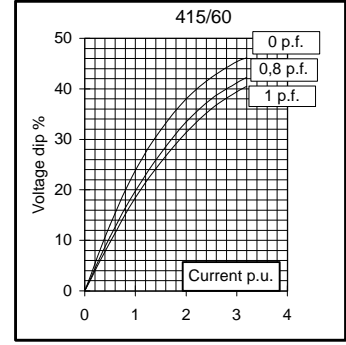
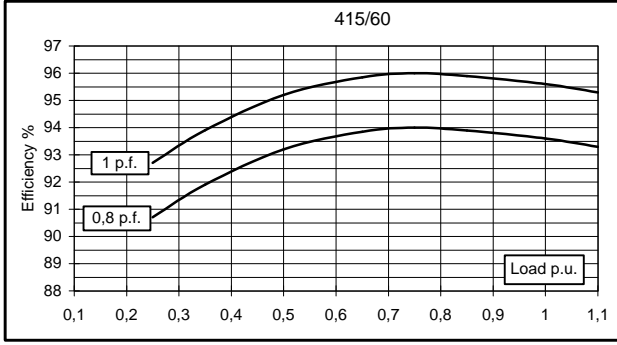

This document is a propriety of Mecc Alte S.p.a.. All rights reserved.

Electrical Characteristics										
Frequency	Hz	50				60				
Voltage (series star)	V	380	400	415	440	415	440	460	480	
Rated power class H	kVA	250	250	250	230	290	300	300	300	
	kW	200	200	200	184	232	240	240	240	
Rated power class F	kVA	230	230	230	215	270	280	280	280	
	kW	184	184	184	172	216	224	224	224	
Regulation with UVR6		±1 % with any power factor and speed variations between -5% +30%								
Insulation class		H								
Execution		Brushless								
Stator winding		12 ends								
Rotor		with damping cage								
Efficiencies class H	4/4	%	93,4	93,5	93,2	93	93,9	94,4	94,5	94,6
(see graph. for details)	3/4	%	93,5	93,8	93,7	93,4	94,4	94,6	94,8	95
	2/4	%	92,4	92,5	92,5	92,3	93,5	93,6	93,7	93,8
	1/4	%	90,2	90	89,8	89,6	90,7	90,7	90,7	90,5
Reactances (f. l.cl. F)	Xd	%	238,2	215	199,7	163,5	278,0	255,9	234,1	215
	Xd'	%	16,1	14,5	13,5	11,0	18,8	17,3	15,8	14,5
	Xd''	%	8,3	7,5	7,0	5,7	9,7	8,9	8,2	7,5
	Xq	%	134,1	121	112,4	92,0	156,5	144,0	131,8	121
	Xq'	%	134,1	121	112,4	92,0	156,5	144,0	131,8	121
	Xq''	%	25,3	22,8	21,2	17,3	29,5	27,1	24,8	22,8
	X ₂	%	18,4	16,6	15,4	12,6	21,5	19,8	18,1	16,6
	X ₀	%	2,8	2,5	2,3	1,9	3,2	3,0	2,7	2,5
Short Circuit Ratio	Kcc		0,40	0,43	0,67	1,10	0,31	0,37	0,40	0,43
Time Constants	Td'	sec.	0,088							
	Td''	sec.	0,014							
	Tdo'	sec.	1,40							
	Tα	sec.	0,0175							
Short Circuit Current Capacity		%	>300				>350			
Excitation at no load	Amp.		0,6	0,71	0,8	0,95	0,4	0,5	0,58	0,7
Excitation at full load	Amp.		2,6	2,7	2,9	3,1	2,2	2,4	2,5	2,6
Overload (long-term)		%	1 hour in a 6 hours period 110% rated load							
Overload per 20 sec.		%	300							
Stator Winding Resistance (20°C)	Ω		0,0068							
Rotor Winding Resistance (20°C)	Ω		5,489							
Exciter Resistance (20 °C)	Ω		Rotor : 0,685				Stator : 15,28			
Heat dissipation at f.l.cl.H	W		14133	13904	14592	13849	15071	14237	13968	13700
Telephone Interference			FHT < 2%				TIF < 40			
Radio interference			EN50081-1, EN50082-1, VDE0875K. For others standards apply to factory							
Waveform Distors.(THD) at f. load	LL/LN %		2 / 2,1							
Waveform Distors.(THD) at no load	LL/LN %		2,9 / 3,1							
Mechanical characteristics										
Protection			IP 21 (other protection on request)							
DE bearing			6318.2RS							
NDE bearing			6314.2RS							
Weight of wound stator assembly	kg		239							
Weight of wound rotor assembly	kg		152							
Weight of complete generator	kg		692							
Maximun overspeed	rpm		2250							
Unbalanced magnetic pull at f.l.cl.F	kN/mm		5,1							
Cooling air requirement	m ³ /min		32				39			
Inertia Constant (H)	sec.		0,117				0,141			
Noise level at 1m/7m	dB(A)		82 / 69				86 / 73			

50 Hz

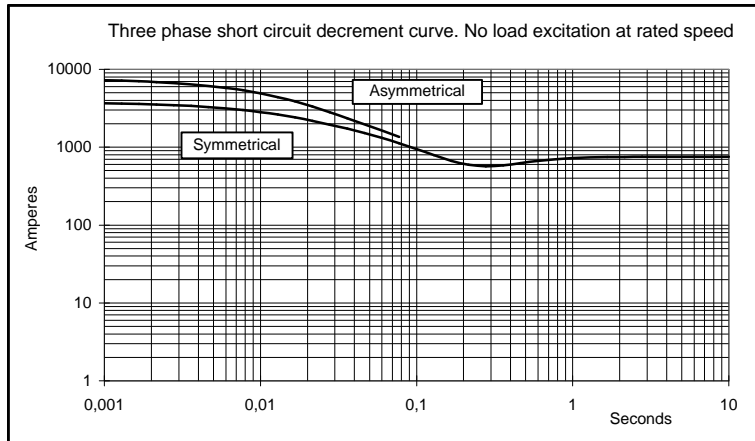
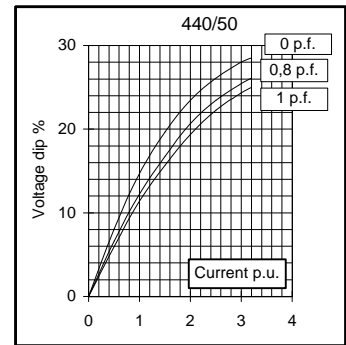
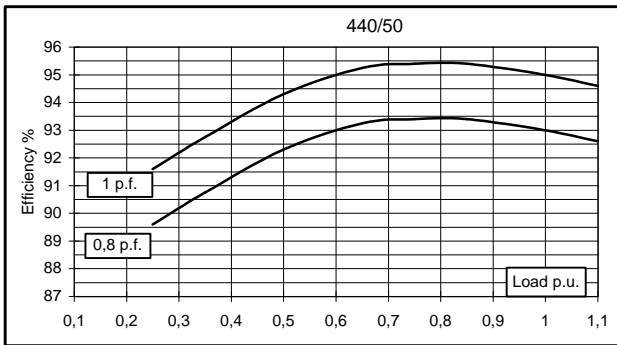
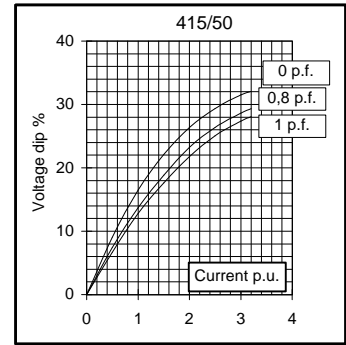
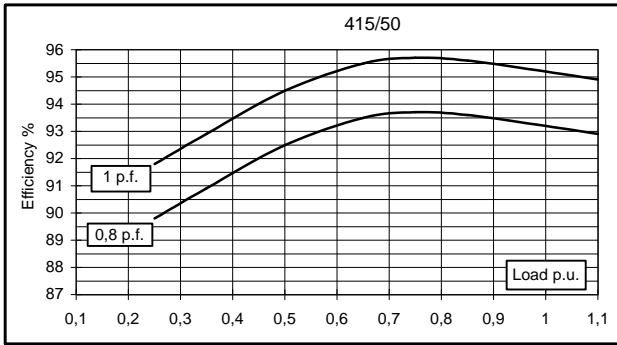
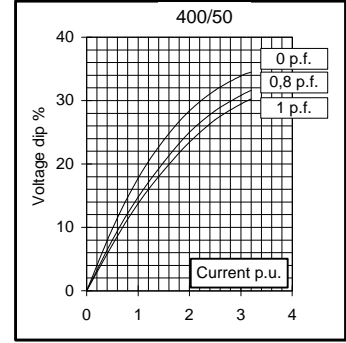
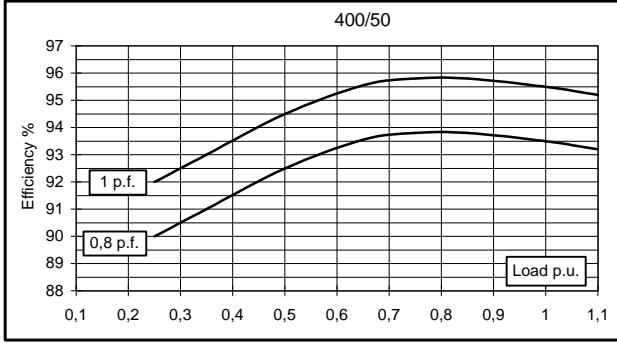
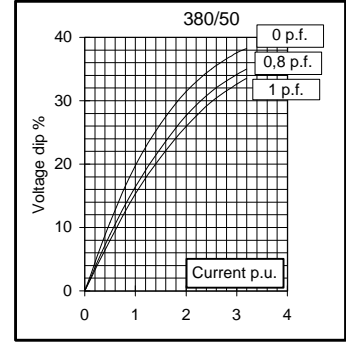
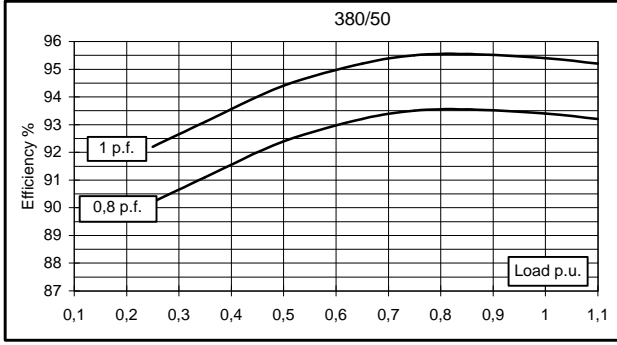

This document is a propriety of Mecc Alte S.p.a.. All rights reserved.

60 Hz

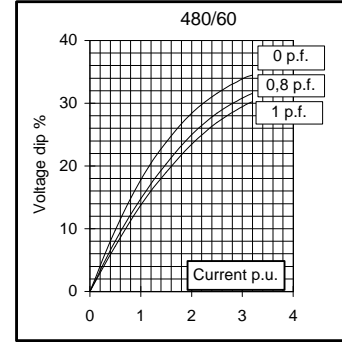
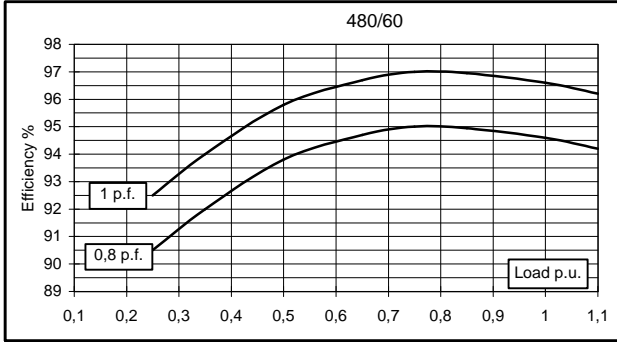
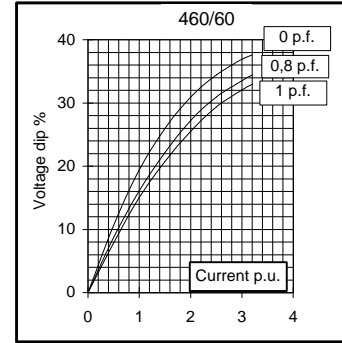
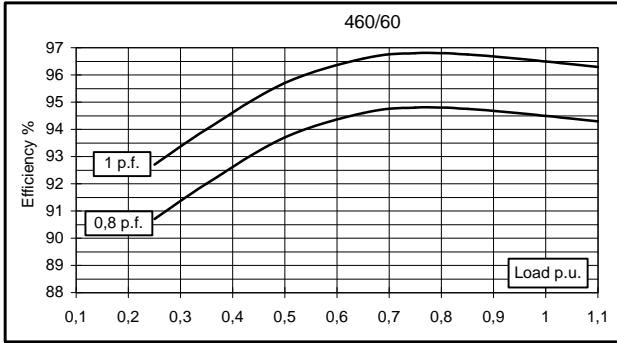
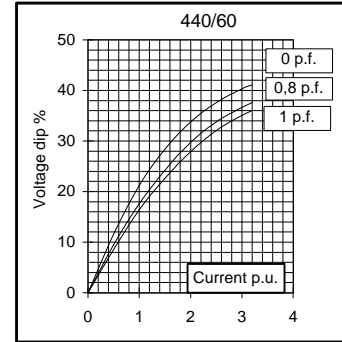
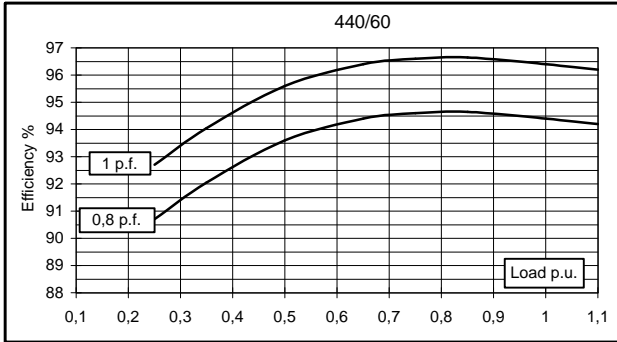
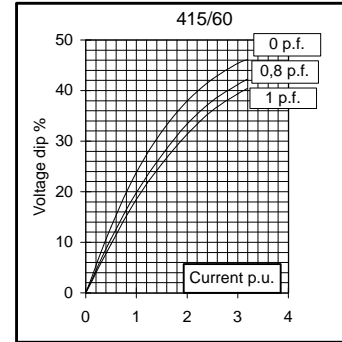
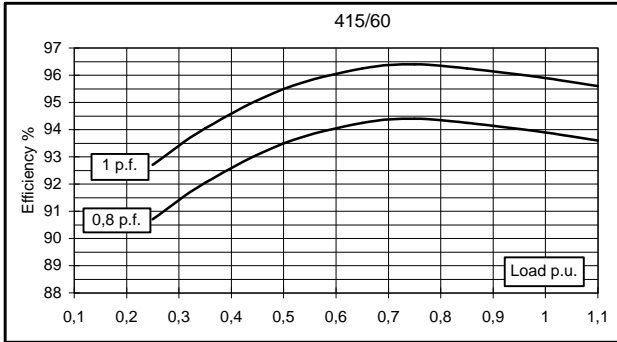

This document is a propriety of Mecc Alte S.p.a.. All rights reserved.

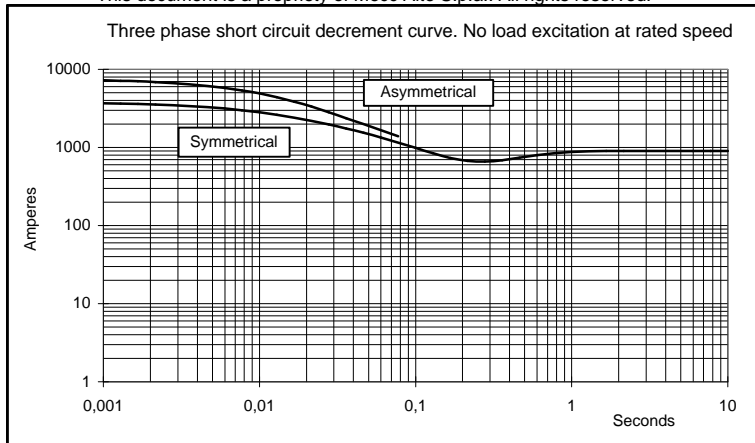

TWO BEARING MOMENTS OF INERTIA

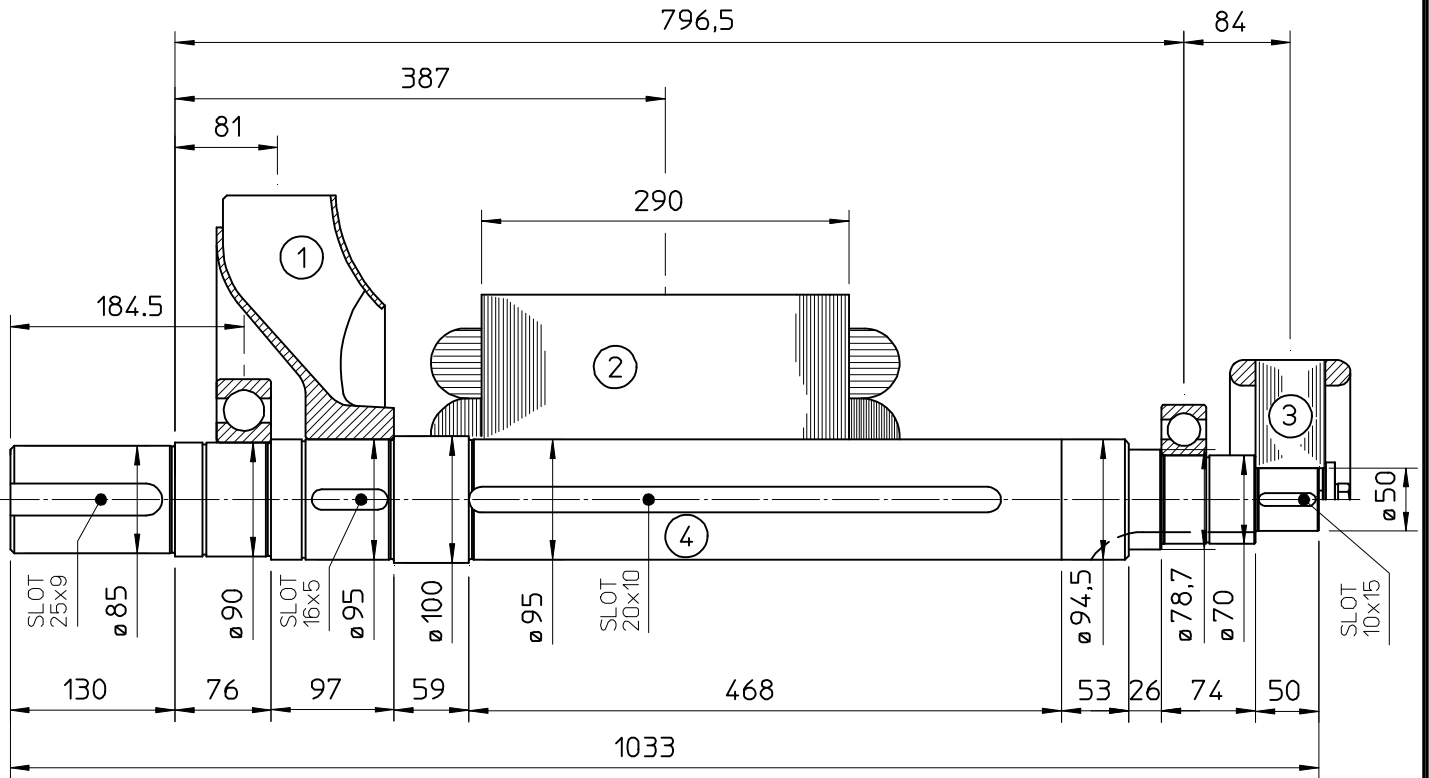

COMPONENT	WEIGHT kg	J kgm ²
1 FAN	6,1	0,1887
2 MAIN ROTOR	152	2,0397
3 EX. ROTOR	14,5	0,0874
4 SHAFT	49,9	0,0525
TOTAL	222,5	2,3683



TWO BEARING DIMENSIONS

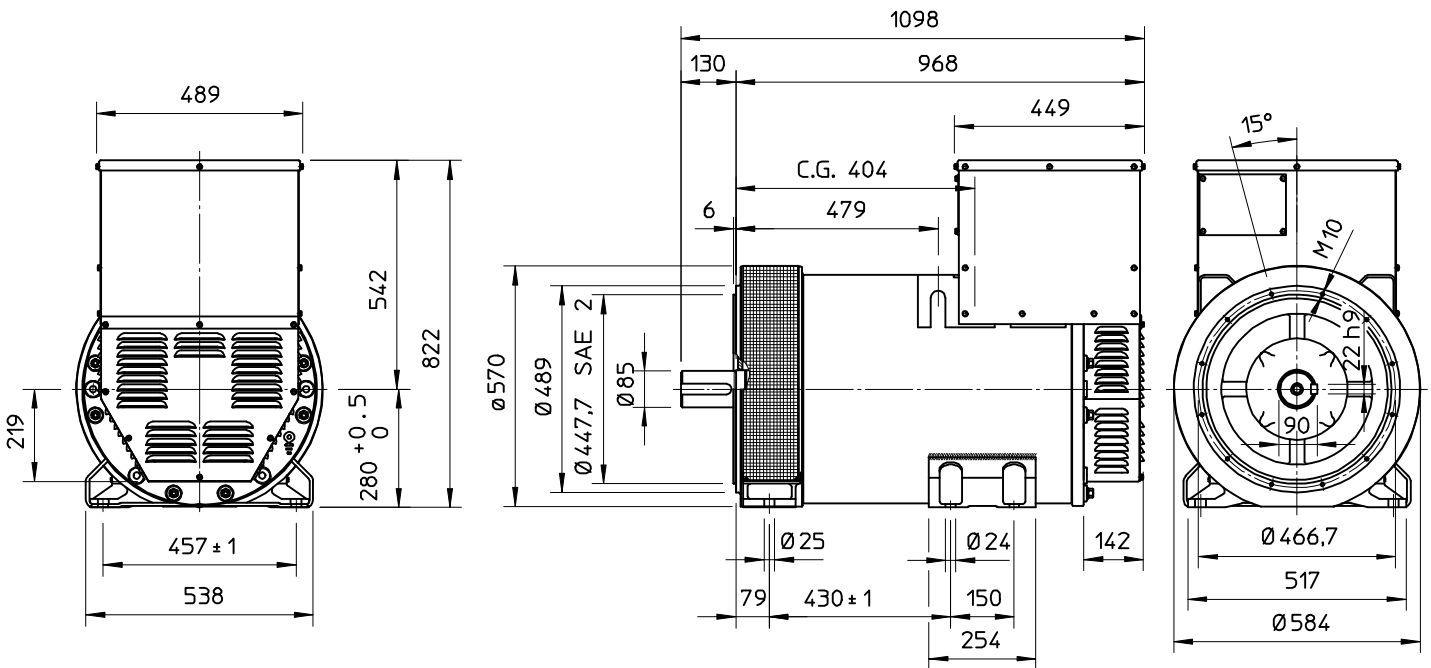

C.G = GRAVITY CENTER

SINGLE BEARING MOMENTS OF INERTIA

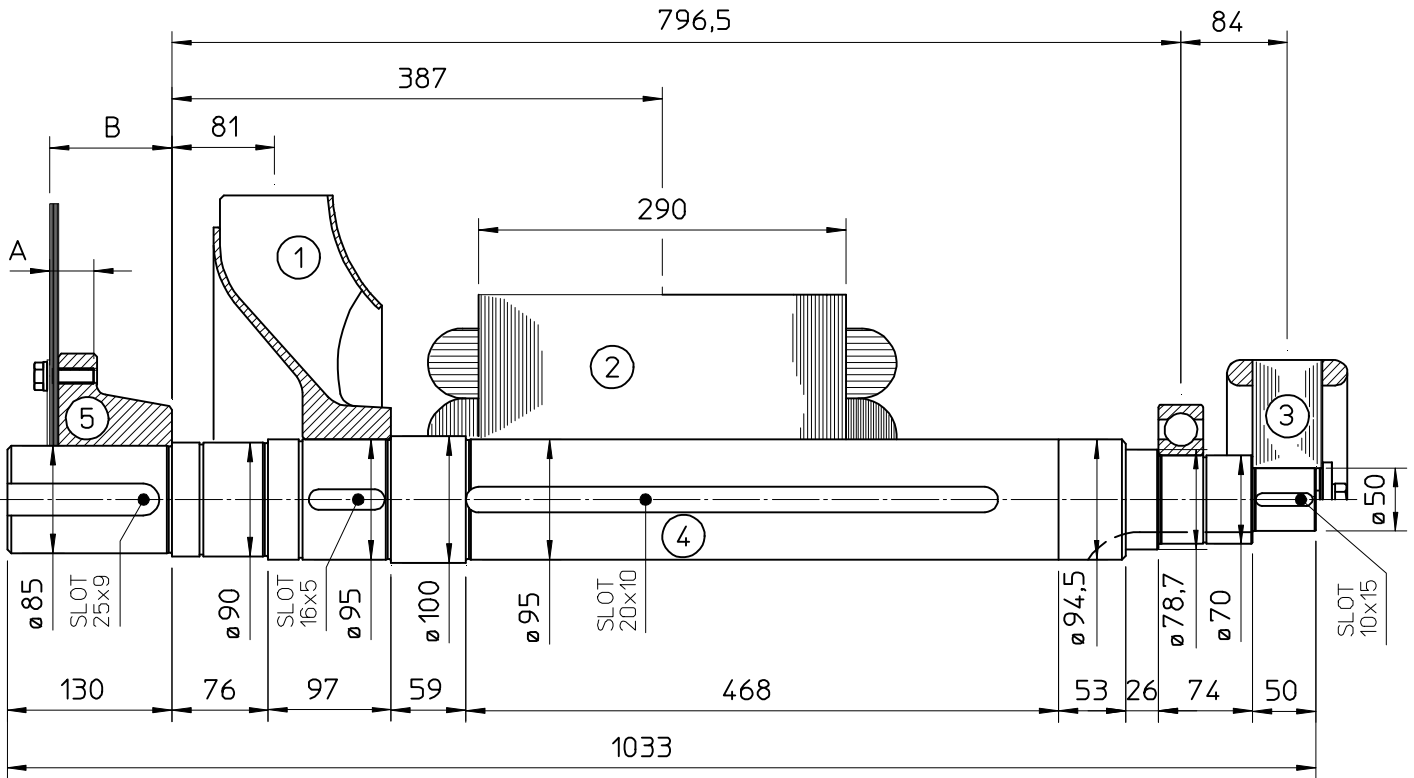

	COMPONENT	WEIGHT kg	J kgm ²
1	FAN	6,1	0,1887
2	MAIN ROTOR	152	2,0397
3	EX. ROTOR	14,5	0,0874
4	SHAFT	49,9	0,0525
	TOTAL	222,5	2,3683

SAE No	SHAFTS COUPLING FLEX PLATE			
	A	B	WEIGHT kg	J kgm ²
5				
11.5	41.1	110.4	22,7	0,306
14	34.7	96.4	22,7	0,306

FAMCO
هایپر صنعت

SINGLE BEARING DIMENSIONS

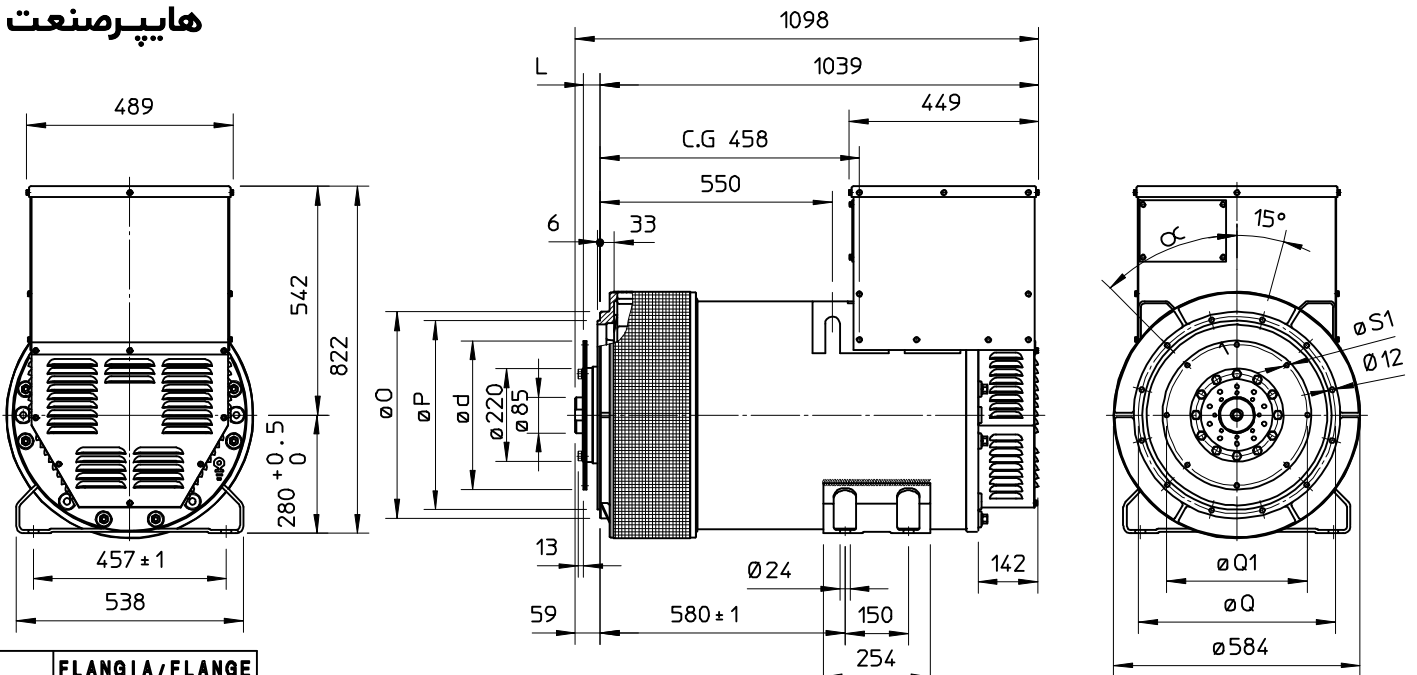

SAE N.	FLANGIA/FLANGE BRIDE/FLANSCH		
	O	P	Q
3	451	409,6	428,6
2	489	447,7	466,7
1	552	511,2	530,2
1/2	648	584,2	619,1

SAE N.	GIUNTI A DISCHI DISC COUPLING DISQUE DE MONOPALIER SCHEIBENKUPPLUNG					
	L	d	Q1	n. fori	S1	α1
11 1/2	39,6	352,42	333,37	8	11	45°
14	25,4	466,72	438,15	8	14	45°

C.G = GRAVITY CENTER

Electrical Characteristics										
Frequency	Hz	50				60				
Voltage (series star)	V	380	400	415	440	415	440	460	480	
Rated power class H	kVA	290	300	300	290	325	340	360	360	
	kW	232	240	240	232	260	272	288	288	
Rated power class F	kVA	265	275	275	265	300	310	330	330	
	kW	212	220	220	212	240	248	264	264	
Regulation with UVR6		±1 % with any power factor and speed variations between -5% +30%								
Insulation class		H								
Execution		Brushless								
Stator winding		12 ends								
Rotor		with damping cage								
Efficiencies class H	4/4	%	93,7	93,8	93,5	93,3	94,1	94,6	94,7	94,8
(see graph. for details)	3/4	%	93,8	94,1	94	93,7	94,6	94,8	95	95,2
	2/4	%	92,7	92,8	92,8	92,6	93,7	93,8	93,9	94
	1/4	%	90,2	90	89,8	89,6	90,7	90,7	90,7	90,5
Reactances (f. l.cl. F)	Xd	%	235,6	220	204,4	175,8	265,7	247,3	239,5	220
	Xd'	%	17,4	16,2	15,1	12,9	19,6	18,2	17,6	16,2
	Xd''	%	9,2	8,6	8,0	6,9	10,4	9,7	9,4	8,6
	Xq	%	136,0	127	118,0	101,5	153,4	142,7	138,3	127
	Xq'	%	136,0	127	118,0	101,5	153,4	142,7	138,3	127
	Xq''	%	23,6	22	20,4	17,6	26,6	24,7	24,0	22
	X ₂	%	18,2	17,0	15,8	13,6	20,5	19,1	18,5	17,0
	X ₀	%	2,6	2,4	2,2	1,9	2,9	2,7	2,6	2,4
Short Circuit Ratio	Kcc		0,38	0,41	0,60	0,95	0,30	0,36	0,38	0,41
Time Constants	Td'	sec.	0,093							
	Td''	sec.	0,0136							
	Tdo'	sec.	1,50							
	Tα	sec.	0,0165							
Short Circuit Current Capacity		%	>300				>350			
Excitation at no load	Amp.		0,6	0,7	0,9	1,2	0,35	0,43	0,55	0,65
Excitation at full load	Amp.		3,6	3,8	3,9	4,1	3,1	3,5	3,5	3,7
Overload (long-term)		%	1 hour in a 6 hours period 110% rated load							
Overload per 20 sec.		%	300							
Stator Winding Resistance (20°C)	Ω		0,0058							
Rotor Winding Resistance (20°C)	Ω		7,739							
Exciter Resistance (20 °C)	Ω		Rotor : 0,685				Stator : 15,28			
Heat dissipation at f.l.cl.H	W		15599	15864	16684	16660	16302	15526	16118	15797
Telephone Interference			FHT < 2%				TIF < 40			
Radio interference			EN50081-1, EN50082-1, VDE0875K. For others standards apply to factory							
Waveform Distors.(THD) at f. load	LL/LN %		3 / 2,9							
Waveform Distors.(THD) at no load	LL/LN %		2,6 / 2,8							
Mechanical characteristics										
Protection			IP 21 (other protection on request)							
DE bearing			6318.2RS							
NDE bearing			6314.2RS							
Weight of wound stator assembly	kg		273							
Weight of wound rotor assembly	kg		190							
Weight of complete generator	kg		790							
Maximun overspeed	rpm		2250							
Unbalanced magnetic pull at f.l.cl.F	kN/mm		5,9							
Cooling air requirement	m ³ /min		32				39			
Inertia Constant (H)	sec.		0,119				0,143			
Noise level at 1m/7m	dB(A)		82 / 69				86 / 73			

50 Hz

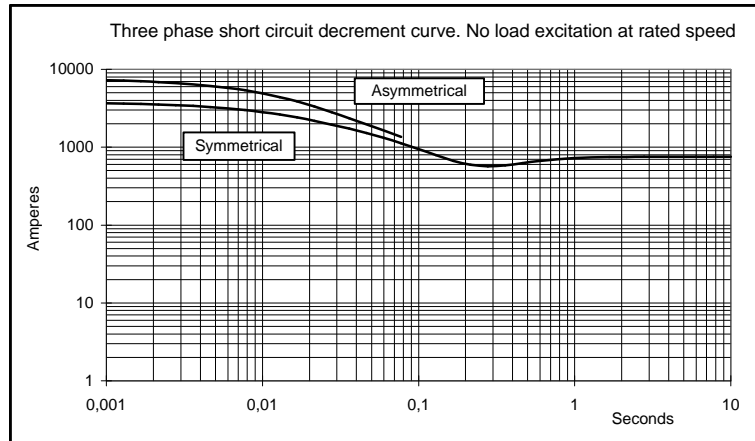
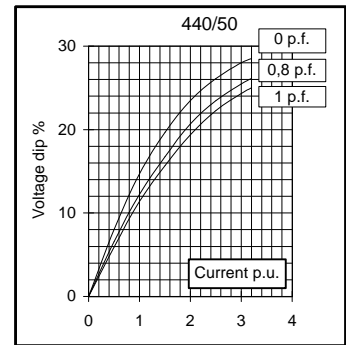
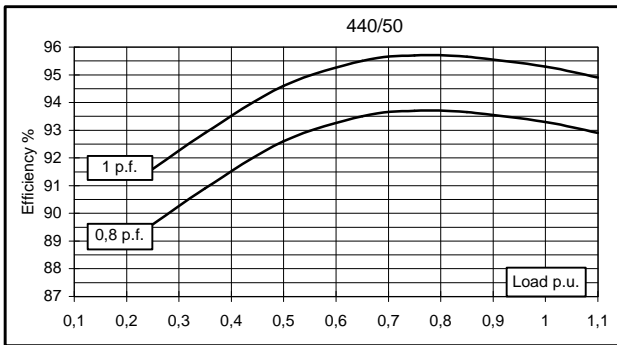
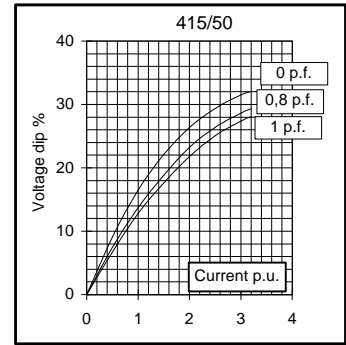
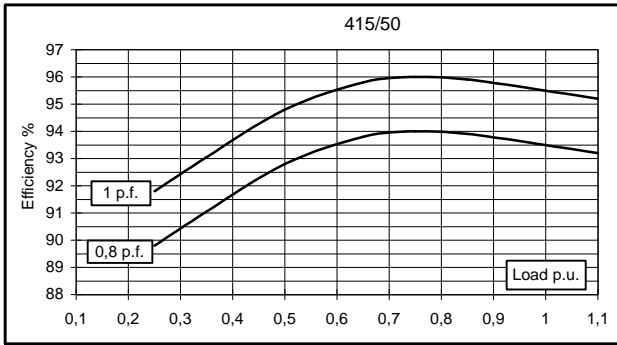
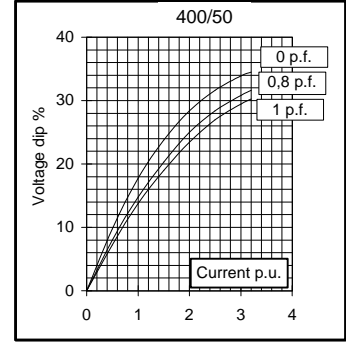
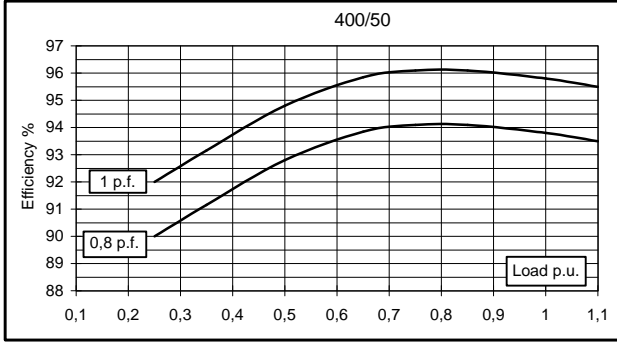
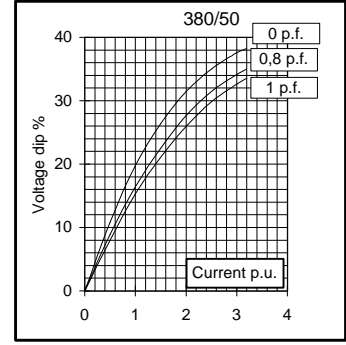
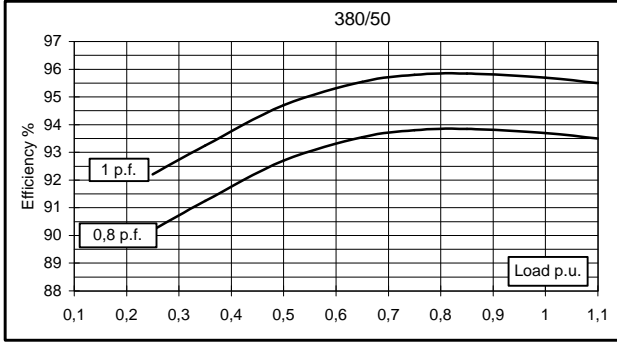

This document is a propriety of Mecc Alte S.p.a.. All rights reserved.

60 Hz

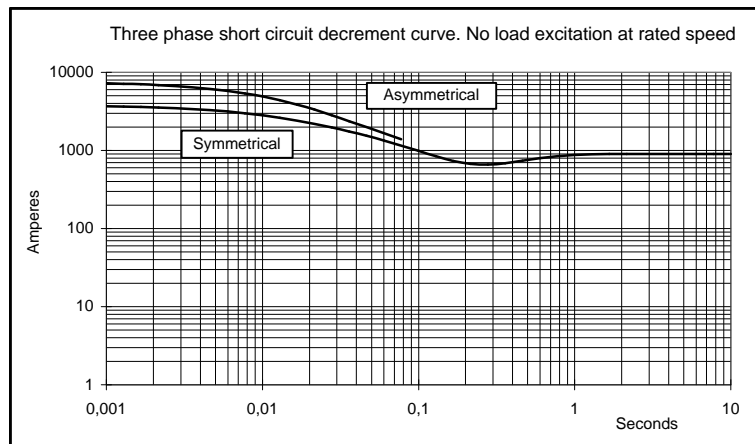
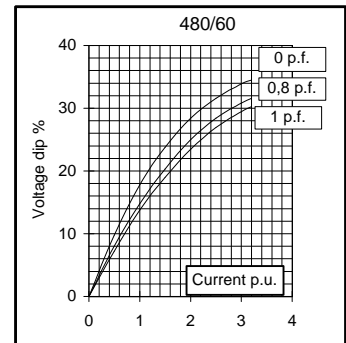
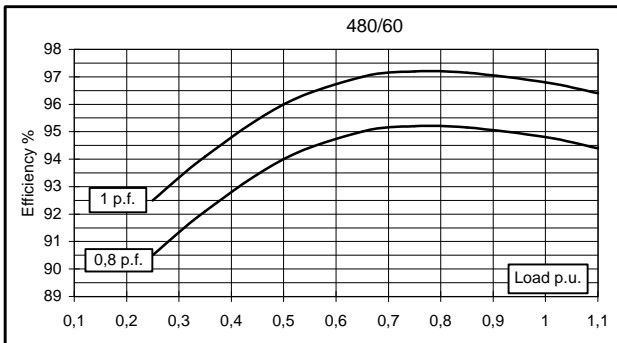
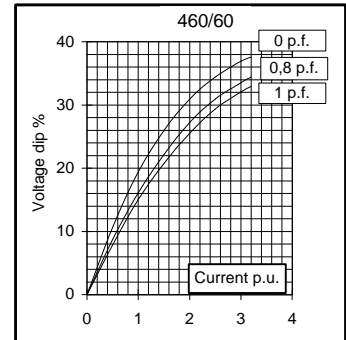
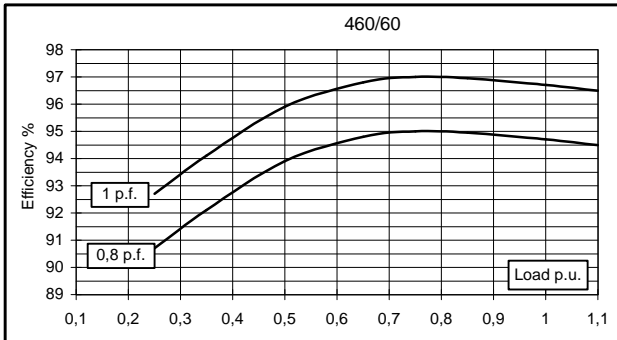
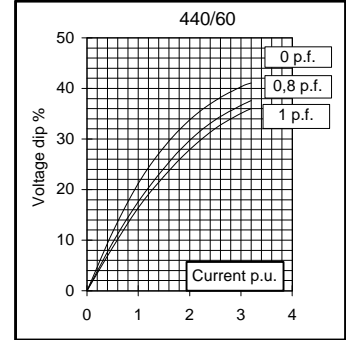
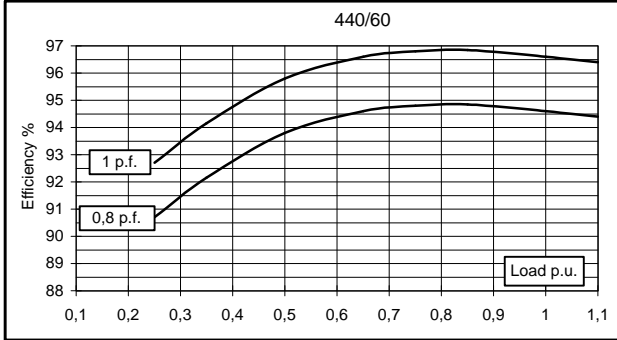
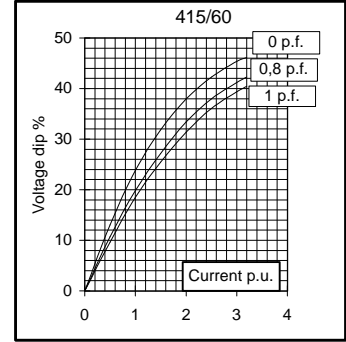
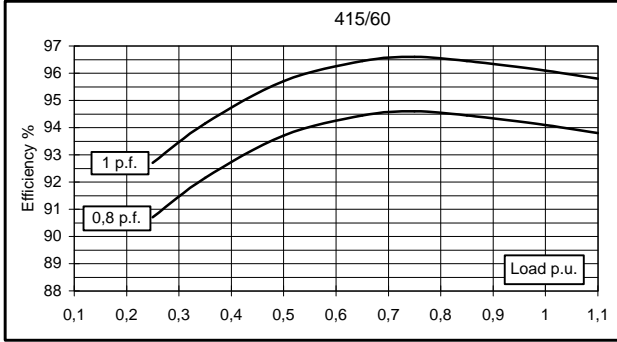

This document is a propriety of Mecc Alte S.p.a.. All rights reserved.

TWO BEARING MOMENTS OF INERTIA

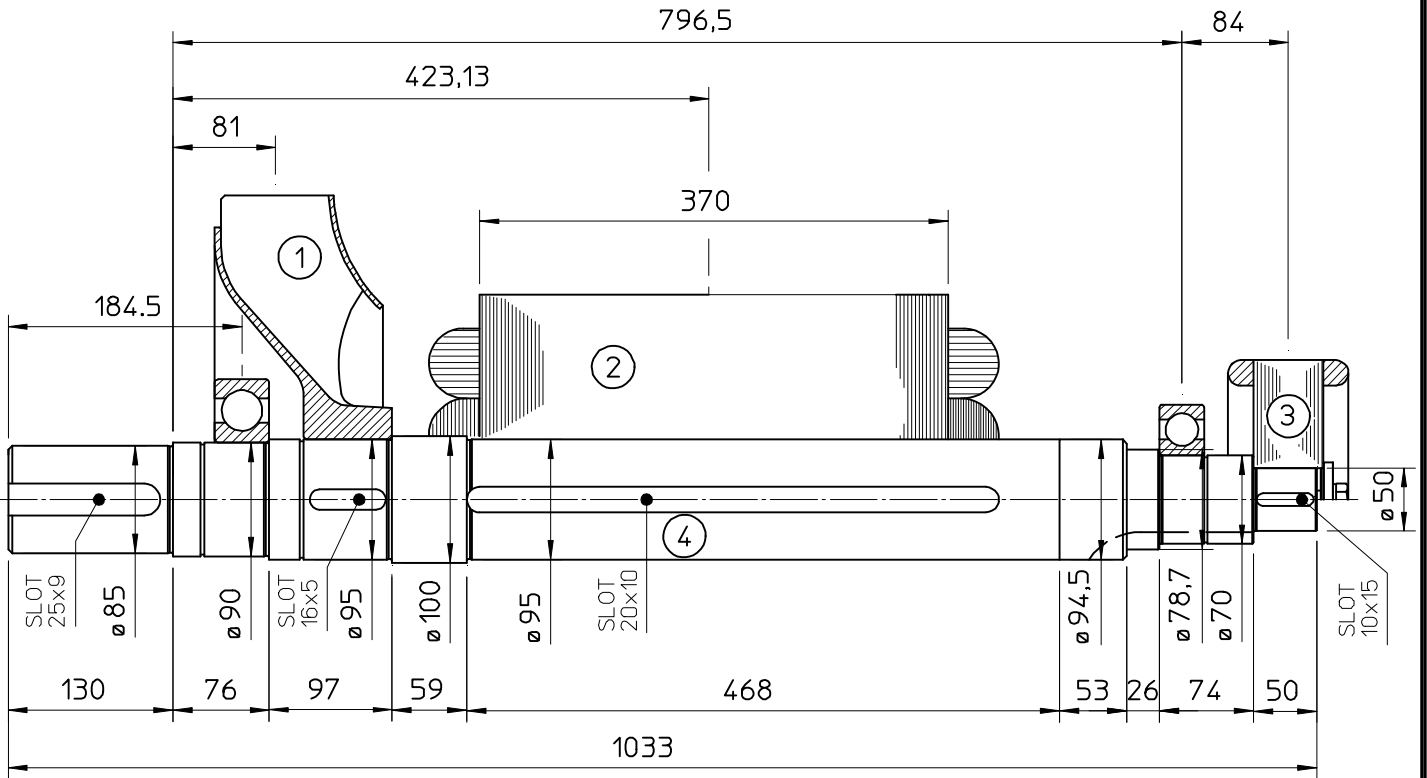

COMPONENT	WEIGHT kg	J kgm ²
1 FAN	6,1	0,1887
2 MAIN ROTOR	190	2,5561
3 EX. ROTOR	14,5	0,0874
4 SHAFT	49,9	0,0525
TOTAL	260,5	2,8847

FAMCO
هایپر صنعت

FAMCO
هایپر صنعت

TWO BEARING DIMENSIONS

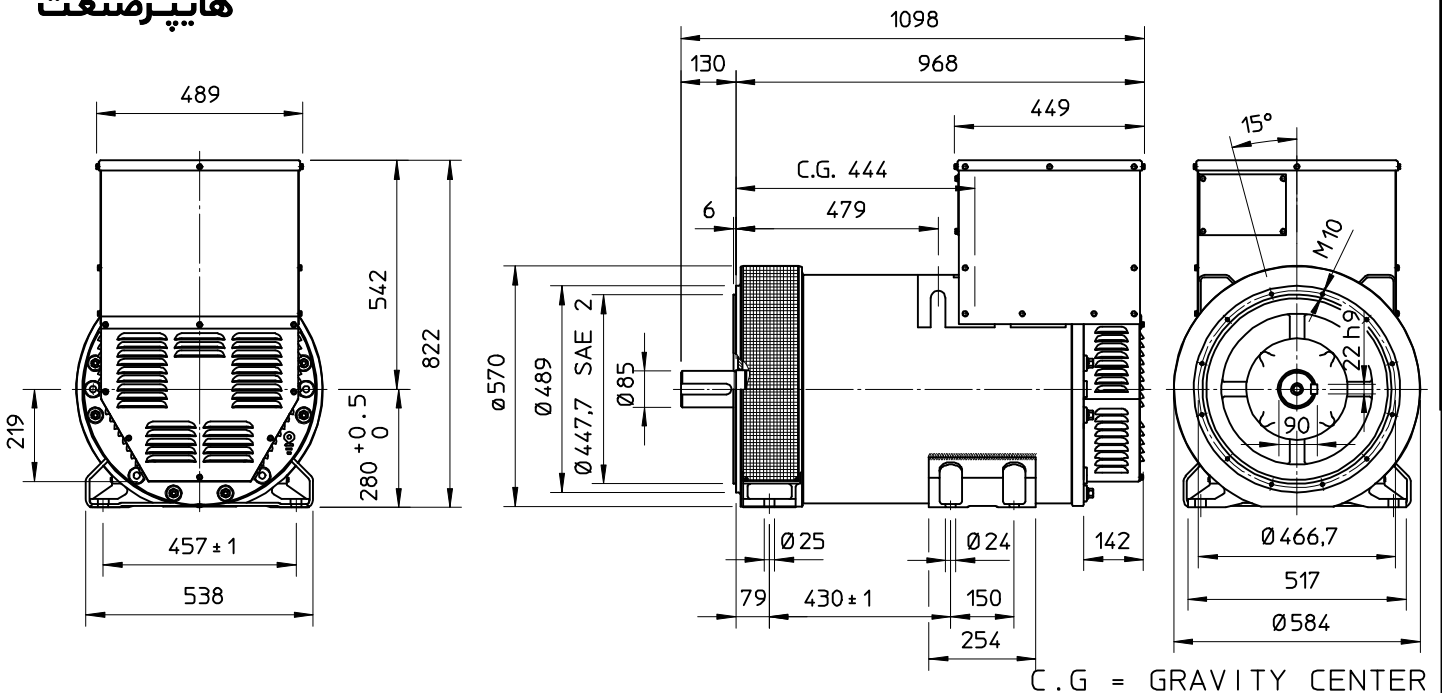

C.G. = GRAVITY CENTER

FAMCO
هایپر صنعت

SINGLE BEARING MOMENTS OF INERTIA

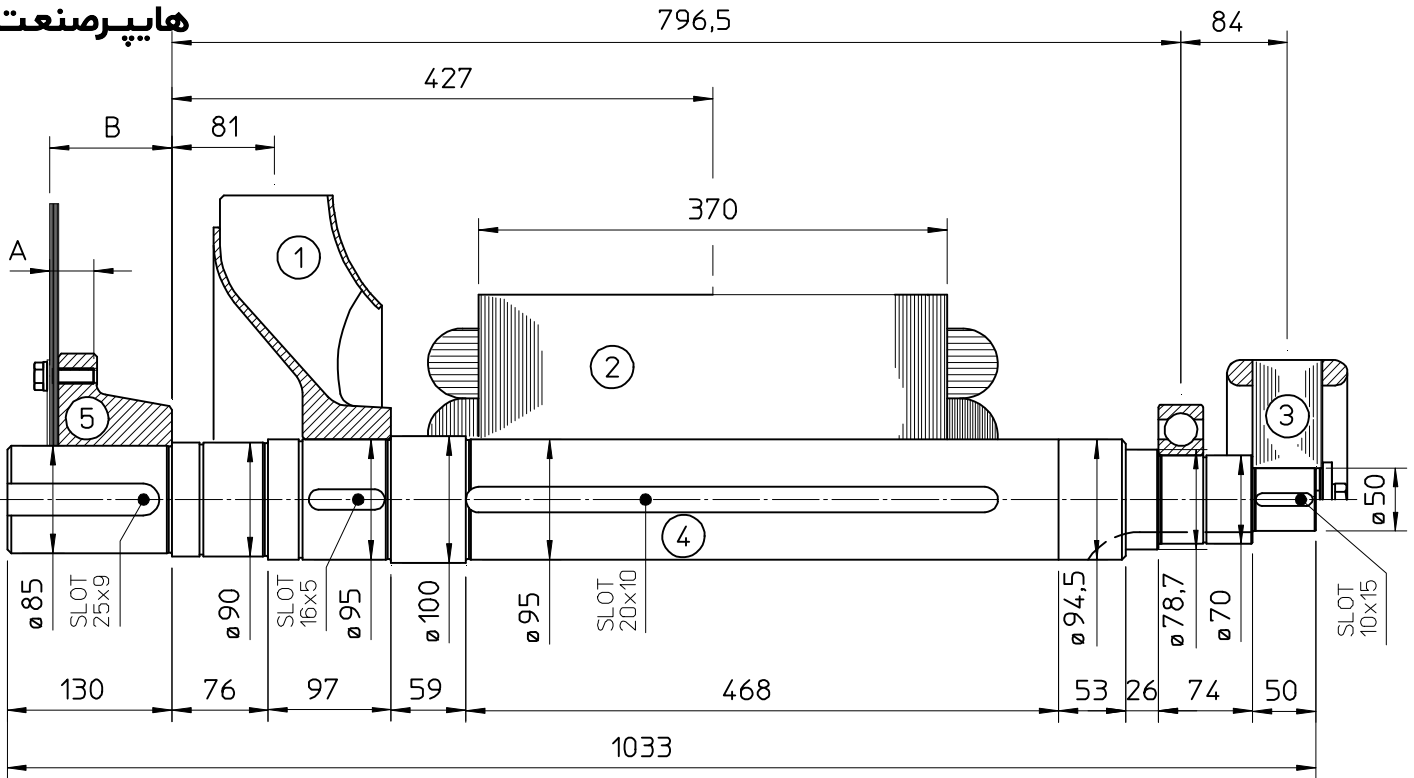

COMPONENT	WEIGHT kg	J kgm ²
1 FAN	6,1	0,1887
2 MAIN ROTOR	190	2,5561
3 EX. ROTOR	14,5	0,0874
4 SHAFT	49,9	0,0525
TOTAL	260,5	2,8847

SAE No	SHAFTS COUPLING FLEX PLATE			
	A	B	WEIGHT kg	J kgm ²
5				
11.5	41.1	110.4	22,7	0,306
14	34.7	96.4	22,7	0,306

FAMCO
هایپر صنعت

SINGLE BEARING DIMENSIONS

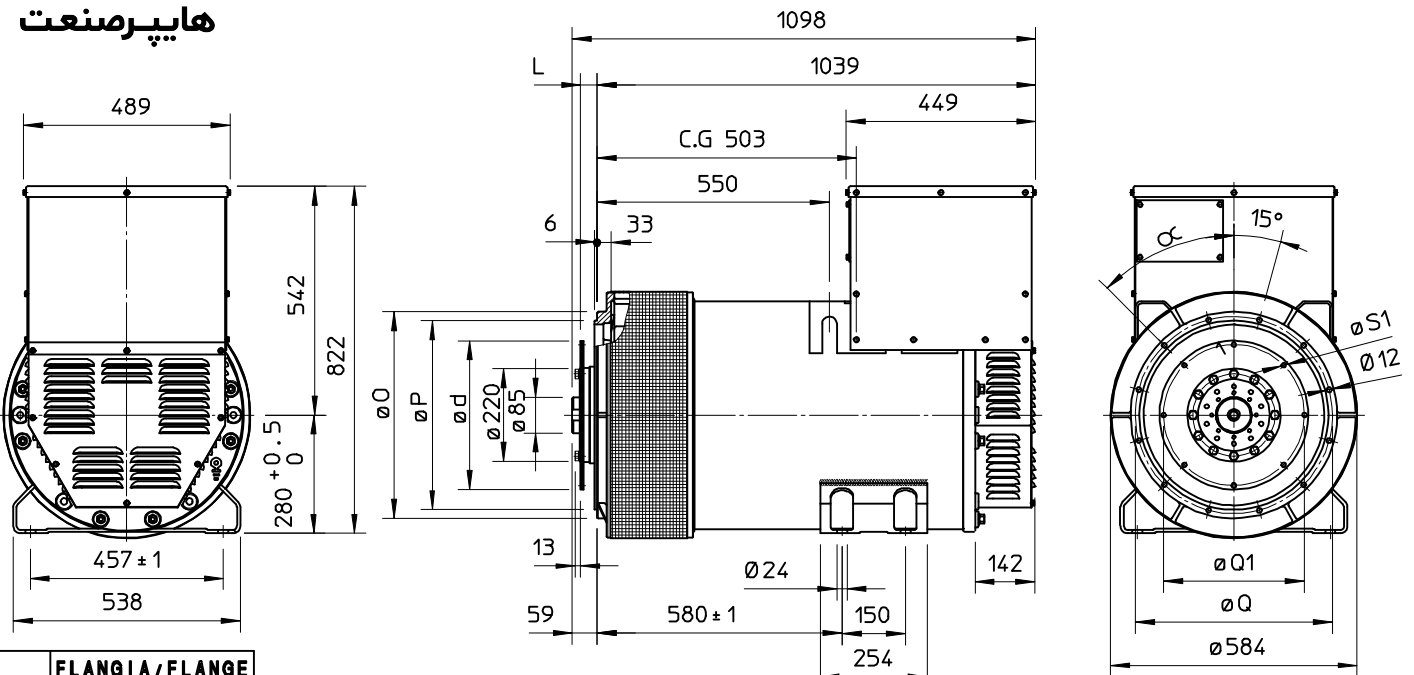

SAE N.	FLANGIA/FLANGE BRIDE/FLANSCH		
	O	P	Q
3	451	409,6	428,6
2	489	447,7	466,7
1	552	511,2	530,2
1/2	648	584,2	619,1

SAE N.	GIUNTI A DISCHI DISC COUPLING DISQUE DE MONOPALIER SCHEIBENKUPPLUNG					
	L	d	Q1	n. fori	S1	α1
11 1/2	39,6	352,42	333,37	8	11	45°
14	25,4	466,72	438,15	8	14	45°

C.G = GRAVITY CENTER

Electrical Characteristics										
Frequency	Hz	50				60				
Voltage (series star)	V	380	400	415	440	415	440	460	480	
Rated power class H	kVA	350	350	350	340	380	420	420	420	
	kW	280	280	280	272	304	336	336	336	
Rated power class F	kVA	320	320	320	310	350	385	385	385	
	kW	256	256	256	248	280	308	308	308	
Regulation with UVR6		±1 % with any power factor and speed variations between -5% +30%								
Insulation class		H								
Execution		Brushless								
Stator winding		12 ends								
Rotor		with damping cage								
Efficiencies class H	4/4	%	93,5	93,6	93,3	93,1	93,7	94,2	94,3	94,4
(see graph. for details)	3/4	%	93,5	93,8	93,7	93,4	94	94,2	94,4	94,6
	2/4	%	92,6	92,7	92,7	92,5	93,1	93,2	93,3	93,4
	1/4	%	90,2	90	89,8	89,6	90,7	90,7	90,7	90,5
Reactances (f. l.cl. F)	Xd	%	282,5	255	236,9	204,7	308,6	303,5	277,7	255
	Xd'	%	19,9	18,0	16,7	14,5	21,8	21,4	19,6	18,0
	Xd''	%	10,9	9,8	9,1	7,9	11,9	11,7	10,7	9,8
	Xq	%	146,3	132	122,6	106,0	159,8	157,1	143,7	132
	Xq'	%	146,3	132	122,6	106,0	159,8	157,1	143,7	132
	Xq''	%	23,3	21	19,5	16,9	25,4	25,0	22,9	21
	X ₂	%	18,2	16,4	15,2	13,2	19,9	19,5	17,9	16,4
	X ₀	%	2,5	2,3	2,1	1,8	2,8	2,7	2,5	2,3
Short Circuit Ratio	Kcc		0,35	0,40	0,55	0,90	0,22	0,30	0,35	0,40
Time Constants	Td'	sec.	0,102							
	Td''	sec.	0,0138							
	Tdo'	sec.	1,60							
	Tα	sec.	0,015							
Short Circuit Current Capacity		%	>300				>350			
Excitation at no load	Amp.		0,5	0,7	0,9	1,2	0,3	0,35	0,47	0,65
Excitation at full load	Amp.		3	3,2	3,4	3,5	2,4	2,6	2,8	3
Overload (long-term)		%	1 hour in a 6 hours period 110% rated load							
Overload per 20 sec.		%	300							
Stator Winding Resistance (20°C)	Ω		0,0044							
Rotor Winding Resistance (20°C)	Ω		7,739							
Exciter Resistance (20 °C)	Ω		Rotor : 0,685				Stator : 15,28			
Heat dissipation at f.l.cl.H	W		19465	19145	20107	20159	20440	20688	20310	19932
Telephone Interference			FHT < 2%				TIF < 40			
Radio interference			EN50081-1, EN50082-1, VDE0875K. For others standards apply to factory							
Waveform Distors.(THD) at f. load	LL/LN %		3,1 / 2,9							
Waveform Distors.(THD) at no load	LL/LN %		2,7 / 2,7							
Mechanical characteristics										
Protection			IP 21 (other protection on request)							
DE bearing			6318.2RS							
NDE bearing			6314.2RS							
Weight of wound stator assembly	kg		363							
Weight of wound rotor assembly	kg		240							
Weight of complete generator	kg		930							
Maximun overspeed	rpm		2250							
Unbalanced magnetic pull at f.l.cl.F	kN/mm		6,2							
Cooling air requirement	m ³ /min		32				39			
Inertia Constant (H)	sec.		0,125				0,150			
Noise level at 1m/7m	dB(A)		82 / 69				86 / 73			

50 Hz

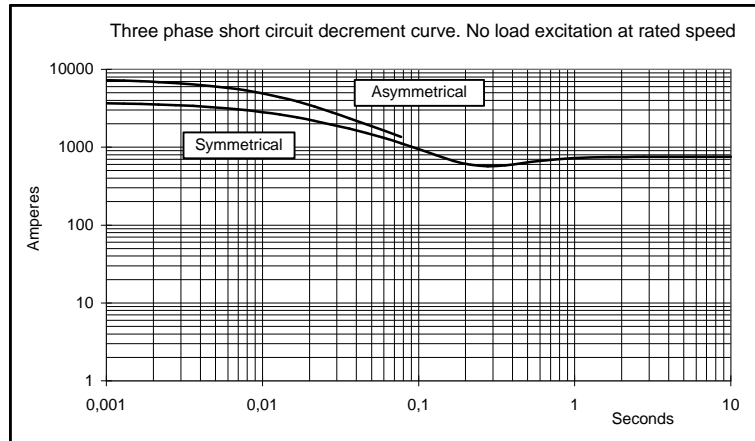
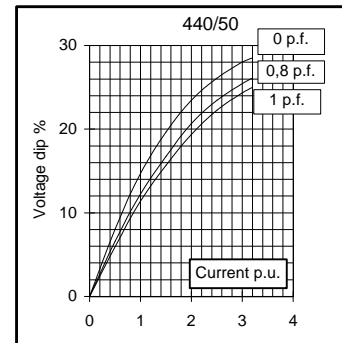
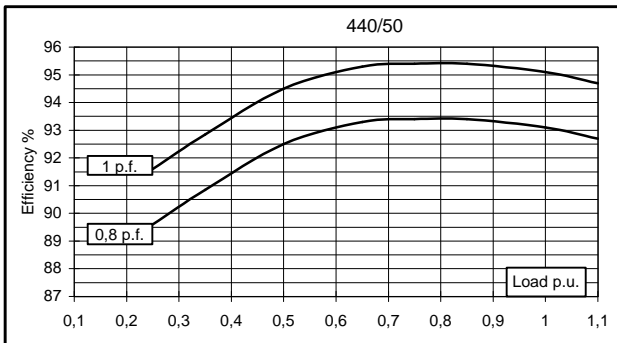
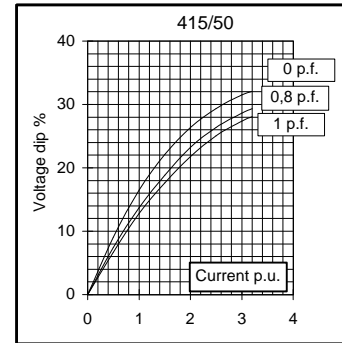
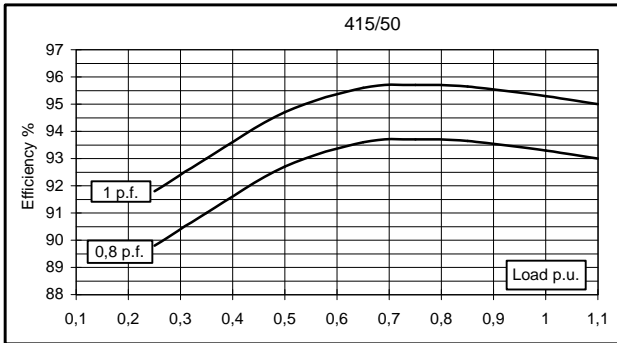
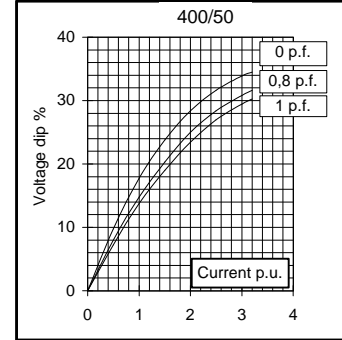
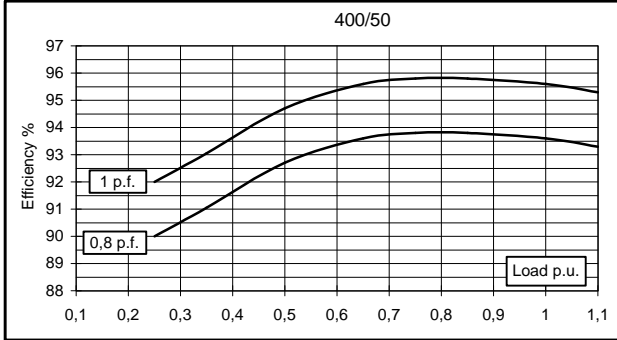
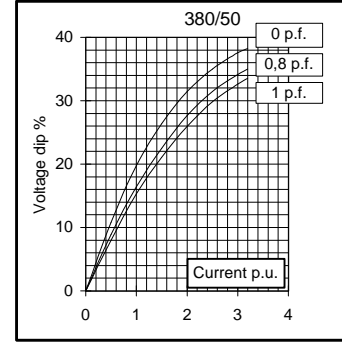
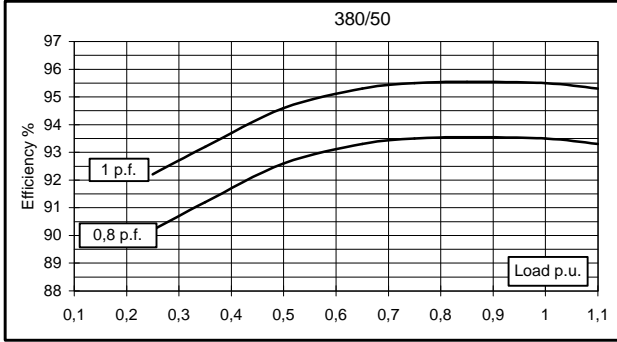

This document is a propriety of Mecc Alte S.p.a.. All rights reserved.

60 Hz

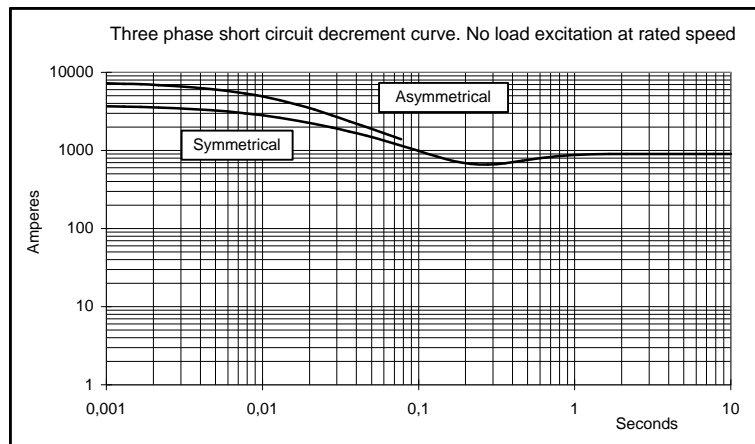
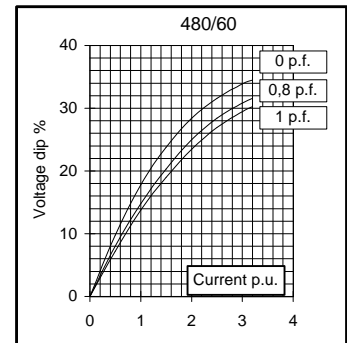
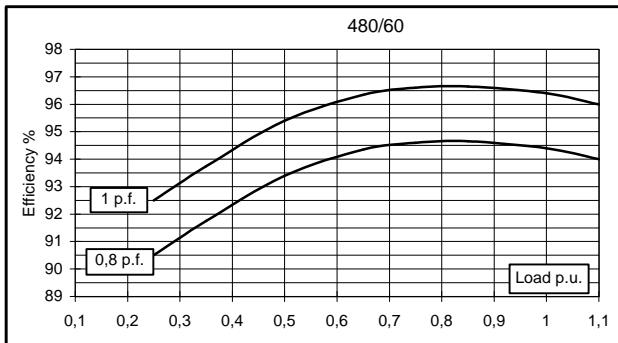
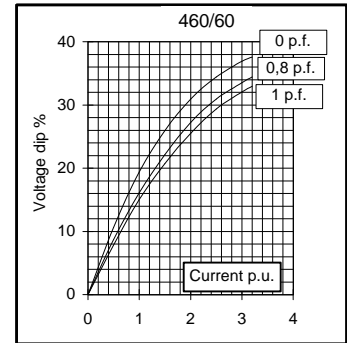
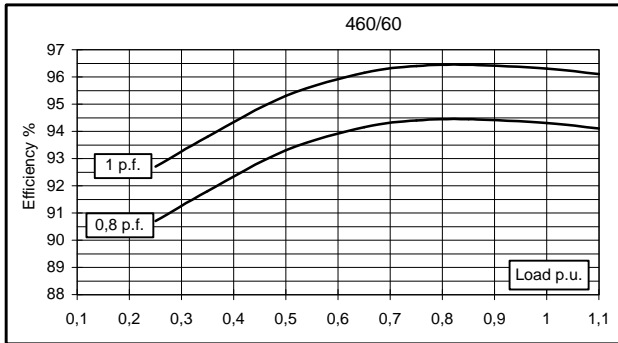
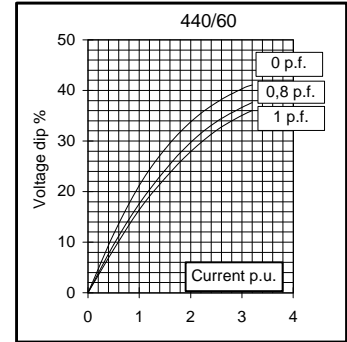
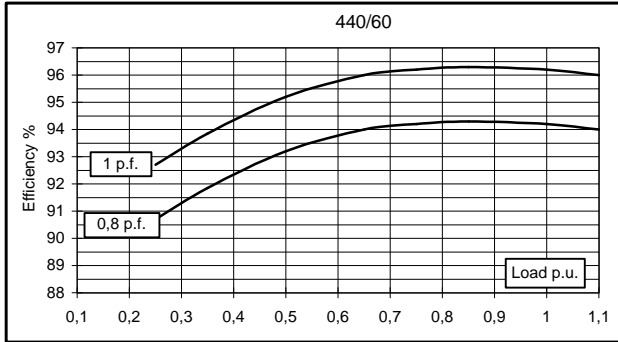
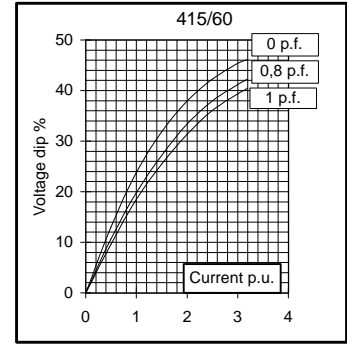
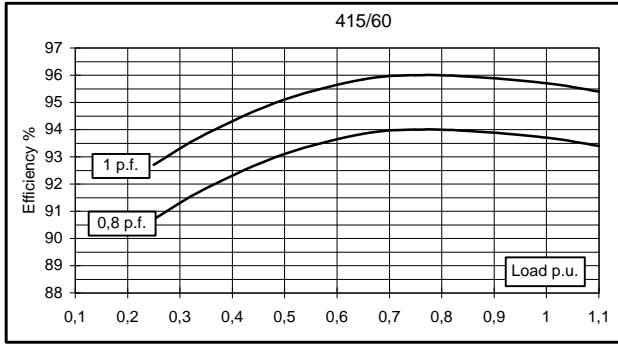

This document is a propriety of Mecc Alte S.p.a.. All rights reserved.

TWO BEARING MOMENTS OF INERTIA

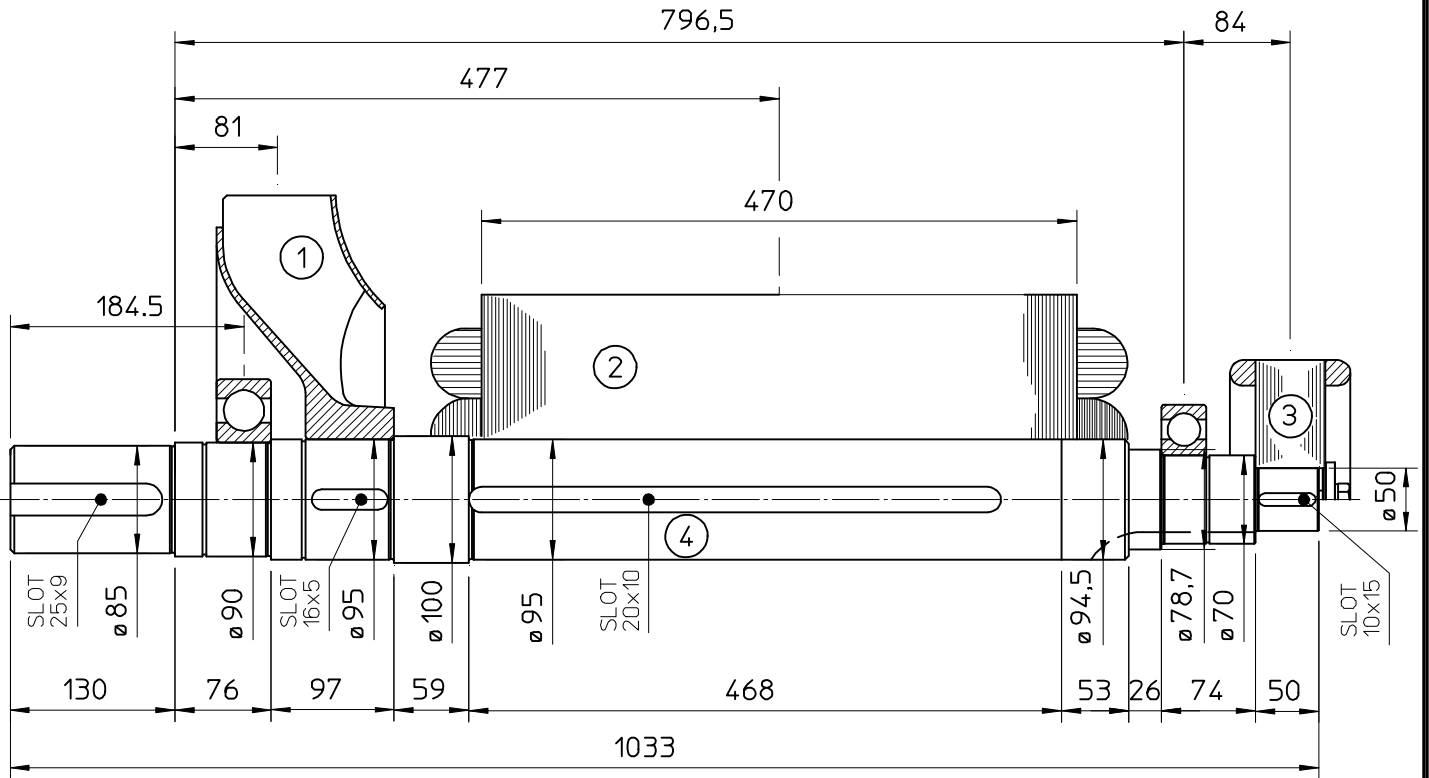

COMPONENT	WEIGHT kg	J kgm ²
1 FAN	6,1	0,1887
2 MAIN ROTOR	240	3,2016
3 EX. ROTOR	14,5	0,0874
4 SHAFT	49,9	0,0525
TOTAL	310,5	3,5302

FAMCO
هایپرمنت

FAMCO
هایپرمنت

TWO BEARING DIMENSIONS

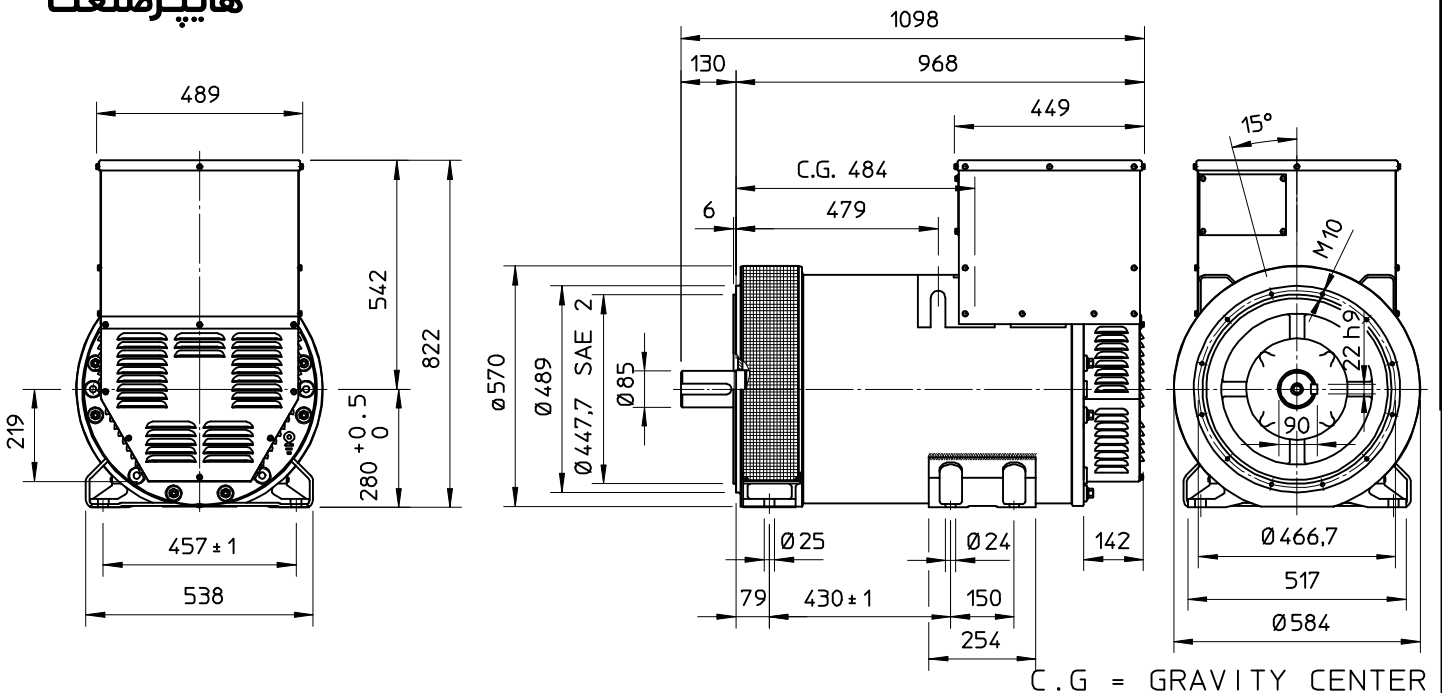

C.G. = GRAVITY CENTER

FAMCO
هایپر صنعت

SINGLE BEARING MOMENTS OF INERTIA

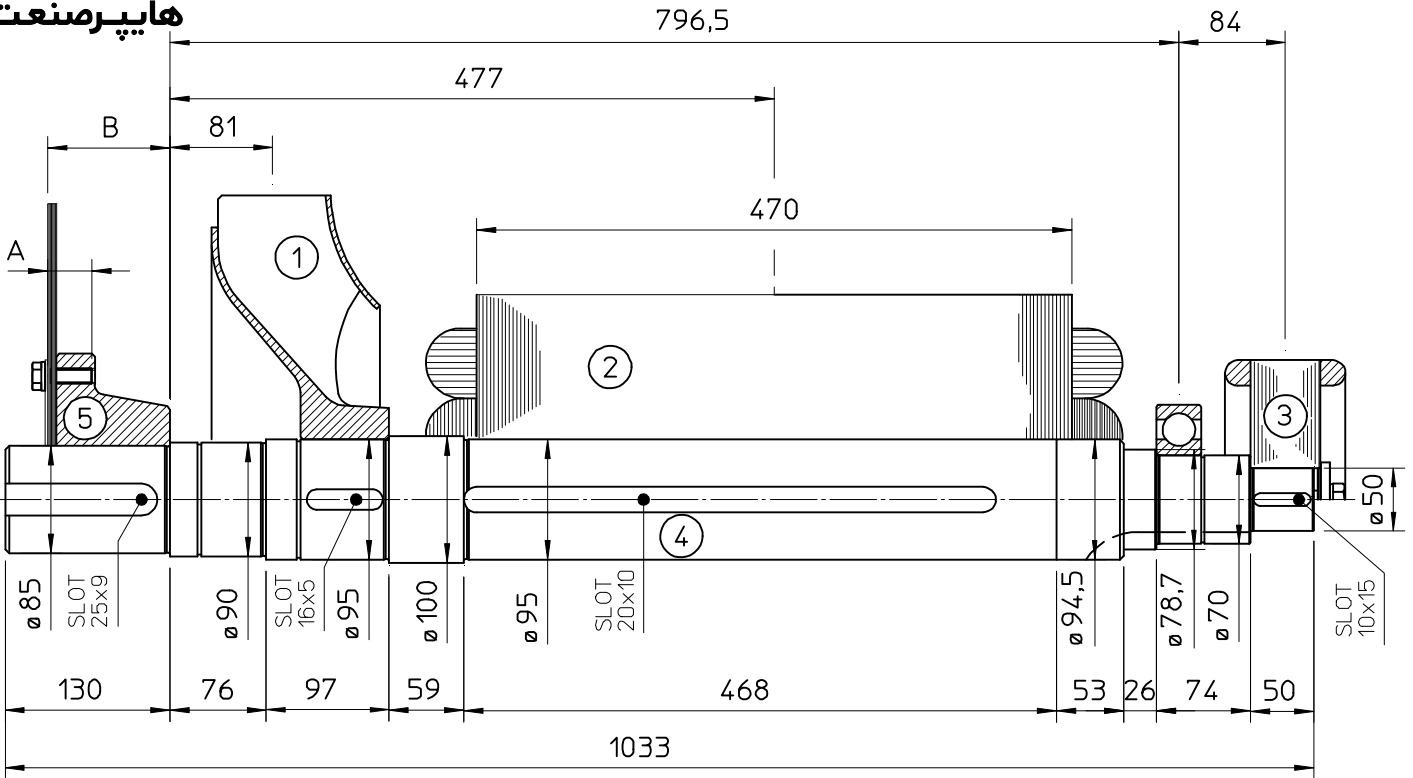

COMPONENT	WEIGHT kg	J kgm ²
1 FAN	6,1	0,1887
2 MAIN ROTOR	240	3,2016
3 EX. ROTOR	14,5	0,0874
4 SHAFT	49,9	0,0525
TOTAL	310,5	3,5302

SAE No	SHAFTS COUPLING FLEX PLATE			
	A	B	WEIGHT kg	J kgm ²
11.5	41.1	110.4	22,7	0,306
14	34.7	96.4	22,7	0,306

FAMCO
هایپر صنعت

SINGLE BEARING DIMENSIONS

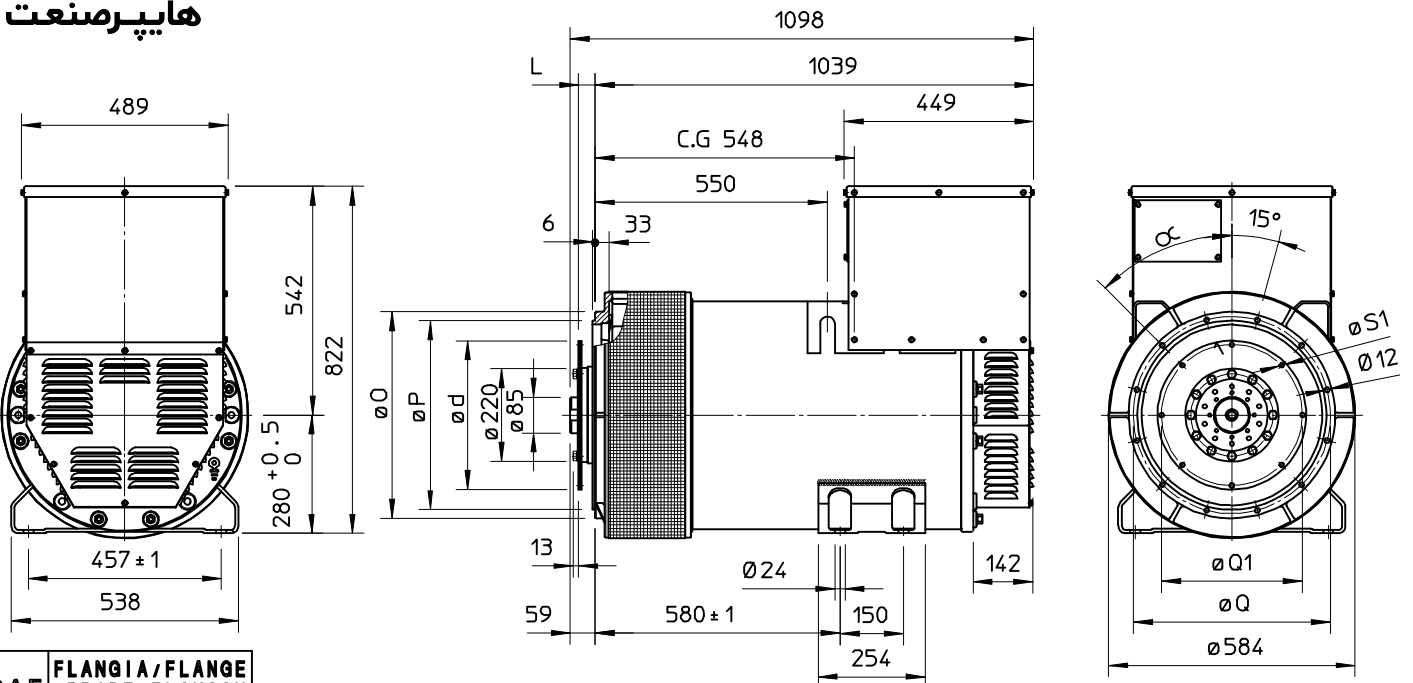

SAE N.	FLANGIA/FLANGE BRIDE/FLANSCH		
	O	P	Q
3	451	409,6	428,6
2	489	447,7	466,7
1	552	511,2	530,2
1/2	648	584,2	619,1

SAE N.	GIUNTI A DISCHI DISC COUPLING DISQUE DE MONOPALIER SCHEIBENKUPPLUNG					
	L	d	Q1	n. fori	S1	α1
11 1/2	39,6	352,42	333,37	8	11	45°
14	25,4	466,72	438,15	8	14	45°

C.G = GRAVITY CENTER

Electrical Characteristics										
Frequency	Hz	50				60				
Voltage (parallel star)	V	380	400	415	440	415	440	460	480	
Rated power class H	kVA	620	620	620	570	660	700	744	744	
	kW	496	496	496	456	528	560	595	595	
Rated power class F	kVA	560	560	560	515	600	632	672	672	
	kW	448	448	448	412	480	506	538	538	
Regulation with UVR6		±1% with any power factor and speed variations between -5% +30%								
Insulation class		H								
Execution		Brushless								
Stator winding		12 ends								
Rotor		with damping cage								
Efficiencies class H	4/4	%	94,2	94,3	94	93,8	95	95,5	95,6	95,7
(see graph. for details)	3/4	%	94,3	94,6	94,5	94,2	95,8	96	96,1	96,4
	2/4	%	93,6	93,7	93,7	93,5	95	95,1	95,2	95,3
	1/4	%	92,6	92,4	92,2	92,1	93,8	93,9	93,9	93,8
Reactances (f. l.cl. F)	Xd	%	300,3	271	251,8	205,9	321,6	303,4	295,1	271
	Xd'	%	29,4	26,5	24,6	20,1	31,4	29,7	28,9	26,5
	Xd''	%	18,2	16,4	15,2	12,5	19,5	18,4	17,9	16,4
	Xq	%	162,9	147	136,6	111,7	174,5	164,6	160,1	147
	Xq'	%	162,9	147	136,6	111,7	174,5	164,6	160,1	147
	Xq''	%	22,5	20,3	18,9	15,4	24,1	22,7	22,1	20,3
	X ₂	%	20,5	18,5	17,2	14,1	22,0	20,7	20,1	18,5
	X ₀	%	3,2	2,9	2,7	2,2	3,4	3,2	3,2	2,9
Short Circuit Ratio	Kcc		0,35	0,40	0,75	1,30	0,23	0,27	0,35	0,40
Time Constants	Td'	sec.	0,132							
	Td''	sec.	0,0164							
	Tdo'	sec.	2,89							
	Tα	sec.	0,037							
Short Circuit Current Capacity		%	>300				>350			
Excitation at no load	Amp.		0,65	0,74	0,8	0,95	0,47	0,54	0,6	0,65
Excitation at full load	Amp.		3	3,1	3,5	3,6	2,3	2,5	2,8	3
Overload (long-term)		%	1 hour in a 6 hours period 110% rated load							
Overload per 20 sec.		%	300							
Stator Winding Resistance (20°C)	Ω		0,0087							
Rotor Winding Resistance (20°C)	Ω		6,832							
Exciter Resistance (20 °C)	Ω		Rotor : 0,317				Stator : 8,85			
Heat dissipation at f.l.cl.H	W		30539	29981	31660	30141	27789	26387	27394	26744
Telephone Interference			FHT < 2%				TIF < 40			
Radio interference			EN50081-1, EN50082-1, VDE0875K. For others standards apply to factory							
Waveform Distors.(THD) at f. load	LL/LN %		2,2 / 2,4							
Waveform Distors.(THD) at no load	LL/LN %		2,4 / 2,5							
Mechanical characteristics										
Protection			IP 21 (other protection on request)							
DE bearing			6322							
NDE bearing			6318.2RS							
Weight of wound stator assembly	kg		524							
Weight of wound rotor assembly	kg		369							
Weight of complete generator	kg		1380							
Maximun overspeed	rpm		2250							
Unbalanced magnetic pull at f.l.cl.F	kN/mm		6,1							
Cooling air requirement	m ³ /min		54				64,8			
Inertia Constant (H)	sec.		0,179				0,214			
Noise level at 1m/7m	dB(A)		94 / 82				98 / 88			

All technical data are to be considered as a reference and they can be modified without any notice.

This document is a propriety of Mecc Alte S.p.A.. All rights reserved.

50 Hz

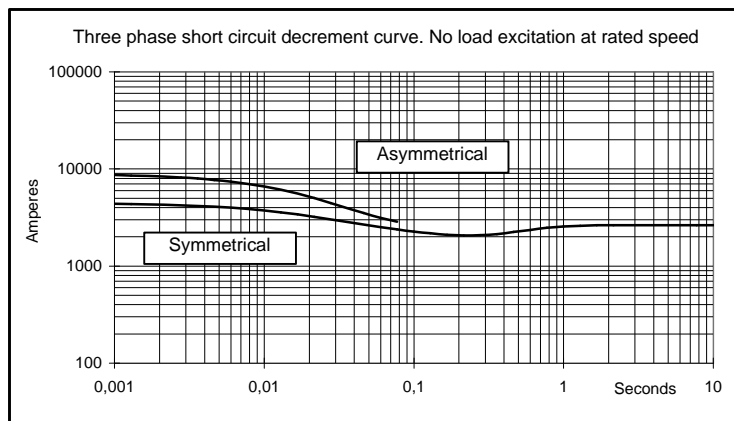
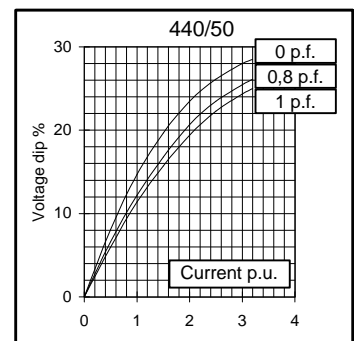
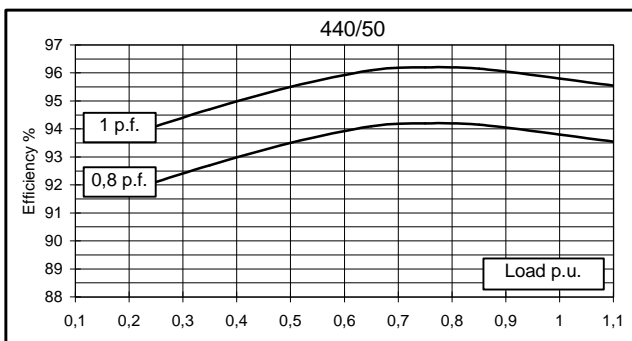
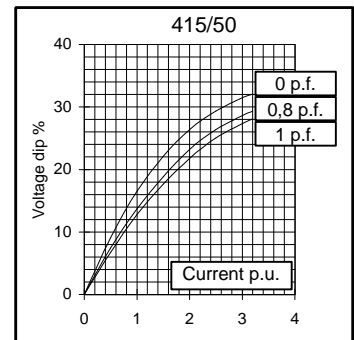
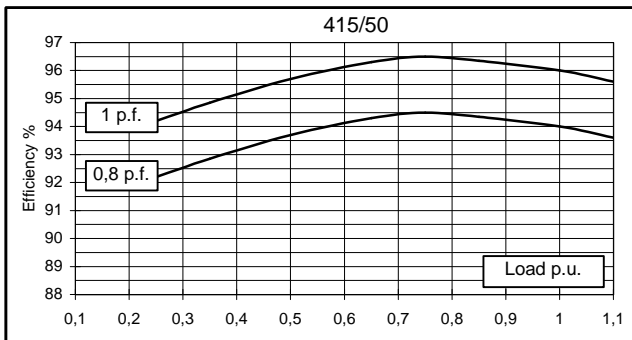
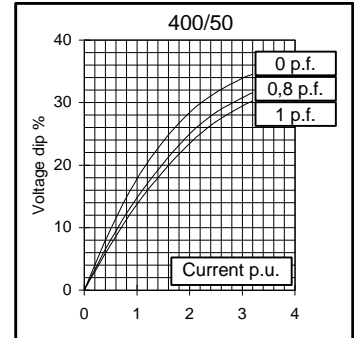
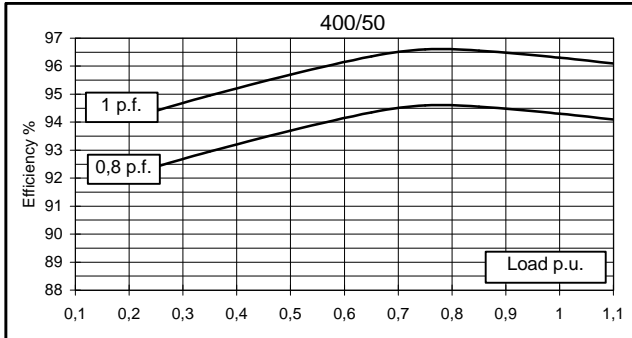
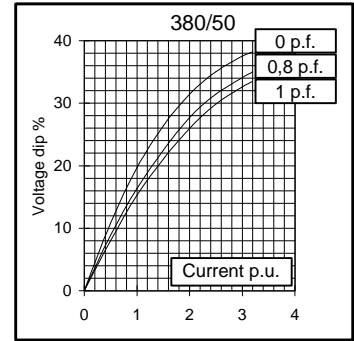
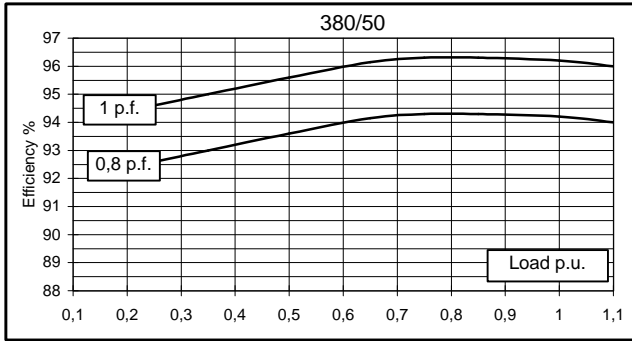

This document is a propriety of Mecc Alte S.p.A.. All rights reserved.

60 Hz

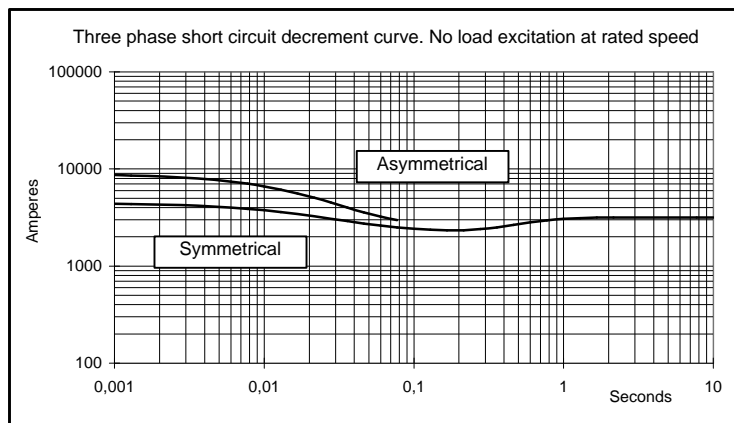
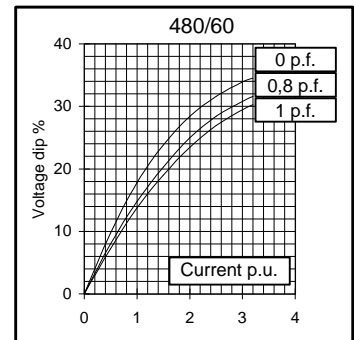
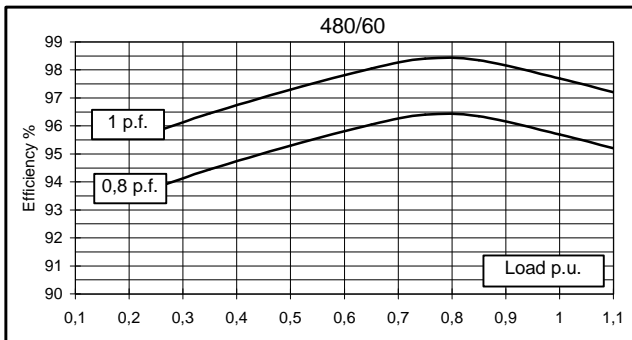
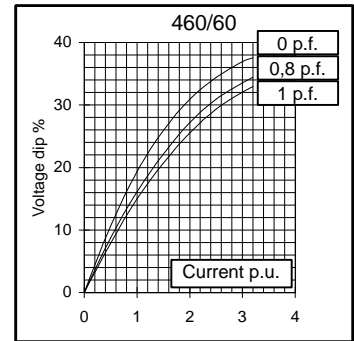
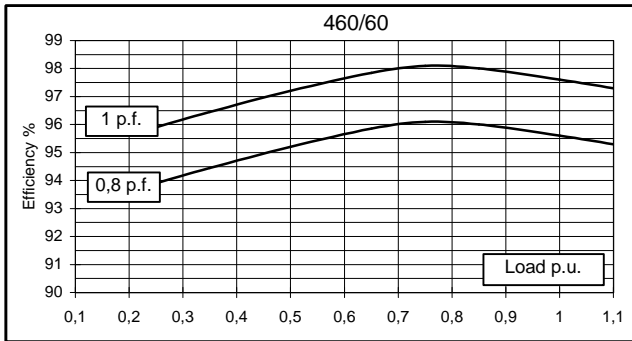
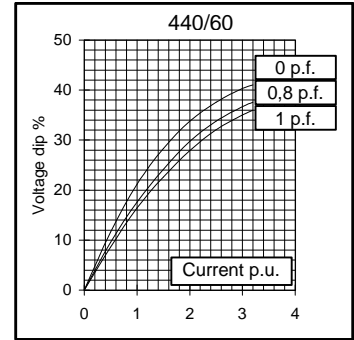
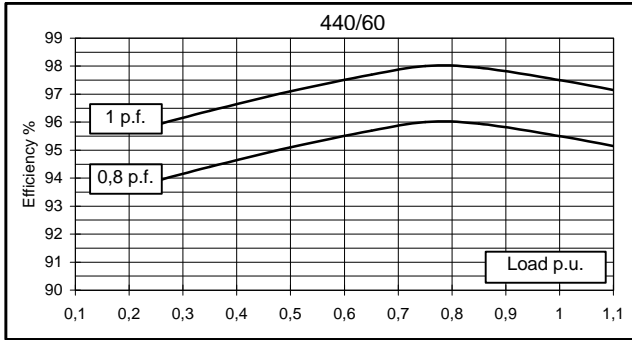
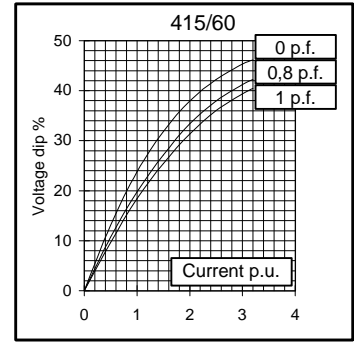
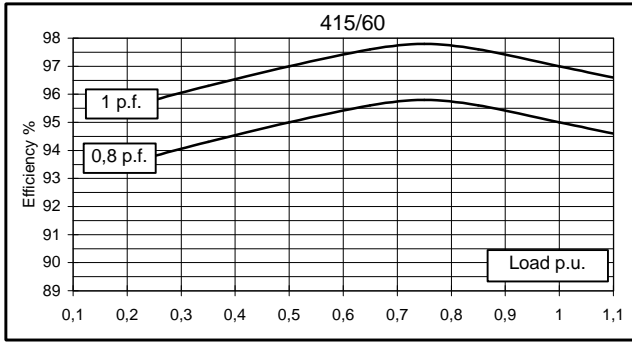

This document is a propriety of Mecc Alte S.p.A.. All rights reserved.

SINGLE BEARING MOMENTS OF INERTIA

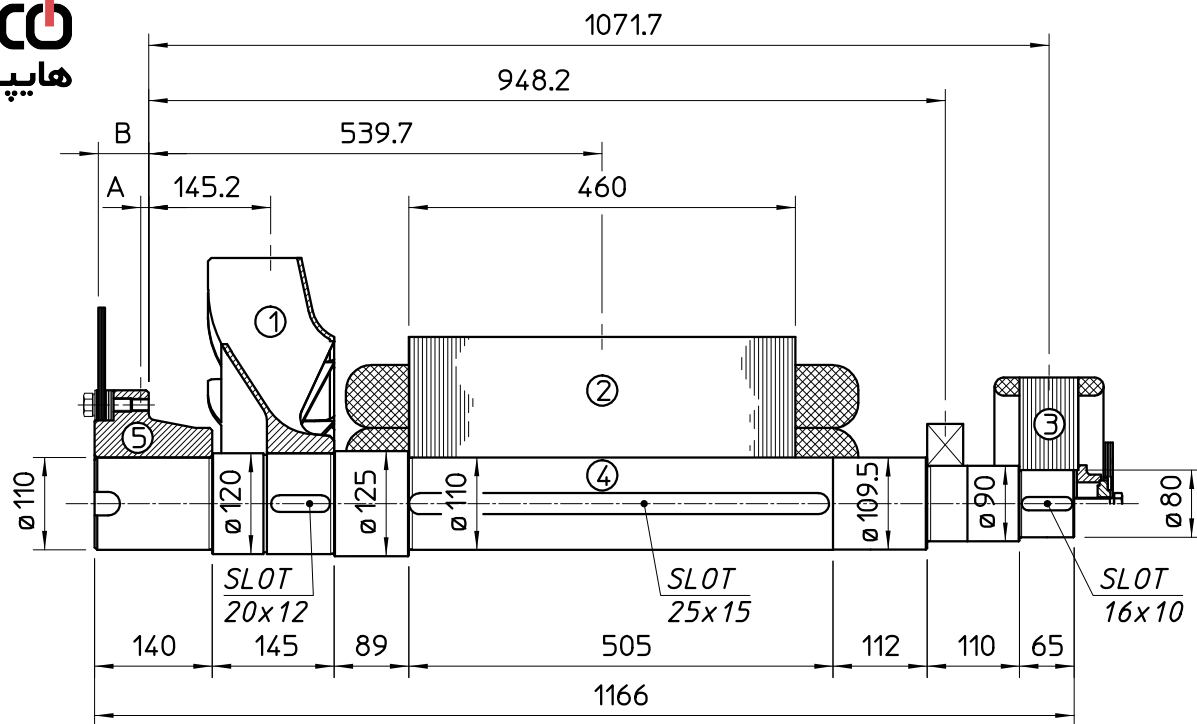

COMPONENT	WEIGHT kg	J kgm ²
1 FAN	16	0.550
2 MAIN ROTOR	369	7.715
3 EX. ROTOR	35	0.562
4 SHAFT	85	0.124
TOTAL	505	8.951

SAE No	SHAFTS COUPLING FLEX PLATE			
	A	B	WEIGHT kg	J kgm ²
14	9,6	60	41,4	0,511
18	6,6	50	45,1	0,858

SINGLE BEARING DIMENSIONS

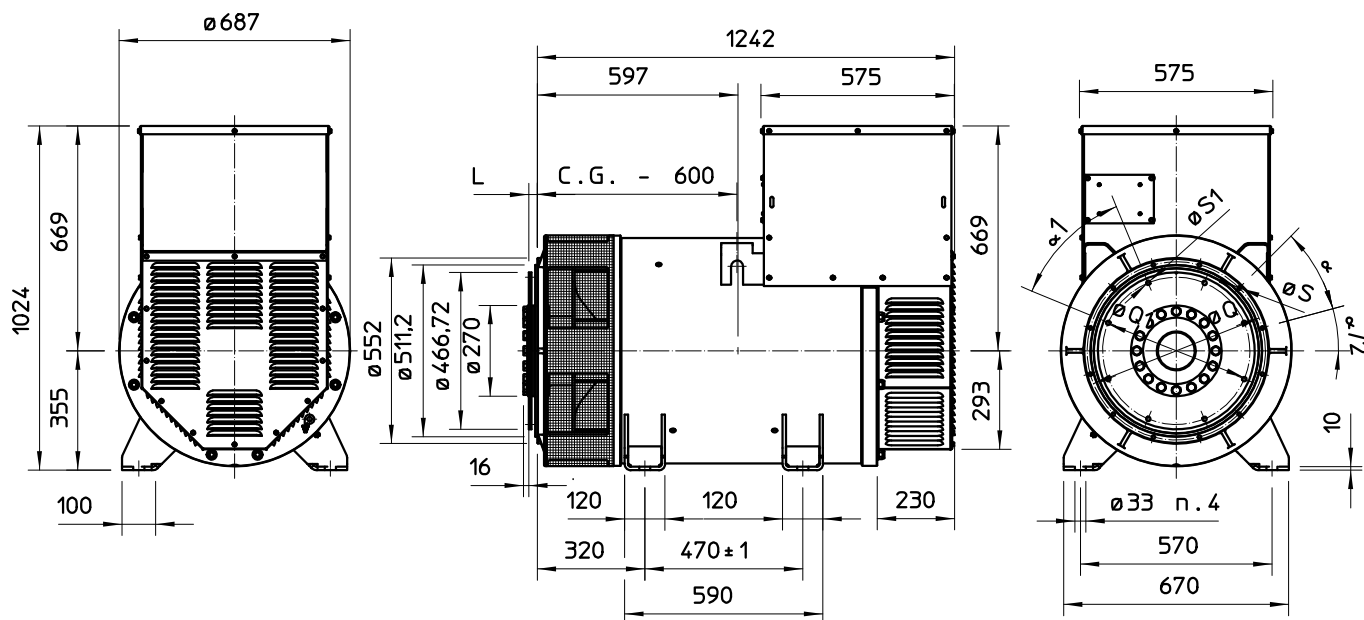

C.G.= GRAVITY CENTER

SAE N.	DISC COUPLING					
	L	d	Q1	N. FORI	S1	Q1
14	25,4	466,72	438,15	8	14	45°
18	15,7	571,5	542,92	6	17	60°

SAE N.	FLANGE					
	O	P	Q	N. FORI	S	Q
1	552	511,2	530,2	12	11	15°
1/2	648	584,2	619,1	12	14	15°
0	711	647,7	679,5	16	14	11°15'
00	883	787,4	850,9	16	14	11°15'

Electrical Characteristics										
Frequency	Hz	50				60				
Voltage (parallel star)	V	380	400	415	440	415	440	460	480	
Rated power class H	kVA	500	500	500	460	540	580	600	600	
	kW	400	400	400	368	432	464	480	480	
Rated power class F	kVA	450	450	450	414	484	520	540	540	
	kW	360	360	360	331	387	416	432	432	
Regulation with UVR6		±1% with any power factor and speed variations between -5% +30%								
Insulation class		H								
Execution		Brushless								
Stator winding		12 ends (nameplate data : 800V-50Hz Series Star, 960V-60Hz Series Star)								
Rotor		with damping cage								
Efficiencies class H	4/4	%	93,8	93,9	93,6	93,4	94,5	95	95,1	95,2
(see graph. for details)	3/4	%	93,9	94,2	94,1	93,8	95	95,2	95,3	95,6
	2/4	%	93,2	93,3	93,3	93,1	94,5	94,6	94,7	94,8
	1/4	%	90,2	90	89,8	89,7	91	91,1	91,1	91
Reactances (f. l.cl. F)	Xd	%	291,3	262,9	244,2	199,9	316,5	302,4	286,3	262,9
	Xd'	%	30,6	27,6	25,6	21,0	33,2	31,8	30,1	27,6
	Xd''	%	20,3	18,3	17,0	13,9	22,0	21,1	19,9	18,3
	Xq	%	179,5	162	150,5	123,2	195,0	186,4	176,4	162
	Xq'	%	179,5	162	150,5	123,2	195,0	186,4	176,4	162
	Xq''	%	25,9	23,4	21,7	17,8	28,2	26,9	25,5	23,4
	X ₂	%	23,0	20,8	19,3	15,8	25,0	23,9	22,6	20,8
	X ₀	%	3,2	2,9	2,7	2,2	3,5	3,3	3,2	2,9
Short Circuit Ratio	Kcc		0,31	0,40	0,60	0,96	0,23	0,27	0,31	0,40
Time Constants	Td'	sec.	0,125							
	Td''	sec.	0,0193							
	Tdo'	sec.	2,71							
	Tα	sec.	0,0258							
Short Circuit Current Capacity		%	>300				>350			
Excitation at no load		Amp.	0,6	0,7	1	1,2	0,4	0,5	0,6	0,7
Excitation at full load		Amp.	3,6	3,5	3,9	4	3	3,1	3,2	3,4
Overload (long-term)		%	1 hour in a 6 hours period 110% rated load							
Overload per 20 sec.		%	300							
Stator Winding Resistance (20°C)		Ω	0,0106							
Rotor Winding Resistance (20°C)		Ω	5,176							
Exciter Resistance (20 °C)		Ω	Rotor : 0,317				Stator : 8,85			
Heat dissipation at f.l.cl.H		W	26439	25985	27350	26004	25143	24421	24732	24202
Telephone Interference			FHT < 2%				TIF < 40			
Radio interference			EN50081-1, EN50082-1, VDE0875K. For others standards apply to factory							
Waveform Distors.(THD) at f. load	LL/LN %		2,4 / 2,5							
Waveform Distors.(THD) at no load	LL/LN %		2,6 / 2,5							
Mechanical characteristics										
Protection			IP 21 (other protection on request)							
DE bearing			6322							
NDE bearing			6318.2RS							
Weight of wound stator assembly	kg		428							
Weight of wound rotor assembly	kg		274,6							
Weight of complete generator	kg		1171							
Maximun overspeed	rpm		2250							
Unbalanced magnetic pull at f.l.cl.F	kN/mm		6,5							
Cooling air requirement	m ³ /min		54				64,8			
Inertia Constant (H)	sec.		0,175				0,210			
Noise level at 1m/7m	dB(A)		94 / 82				98 / 88			

All technical data are to be considered as a reference and they can be modified without any notice.

This document is a propriety of Mecc Alte S.p.A.. All rights reserved.

50 Hz
FAMCO
هایپر صنعت

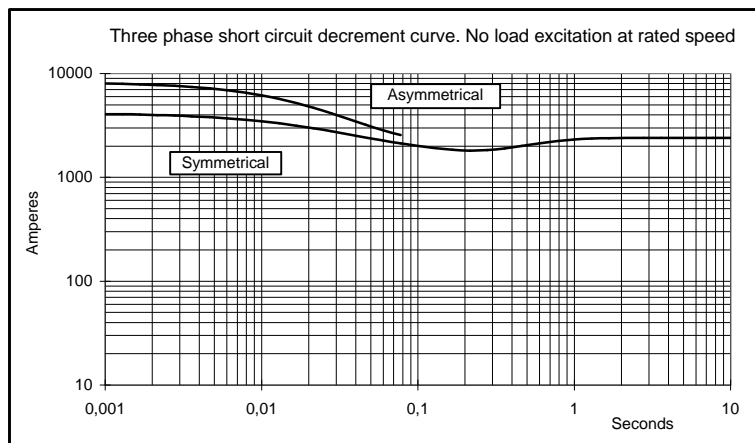
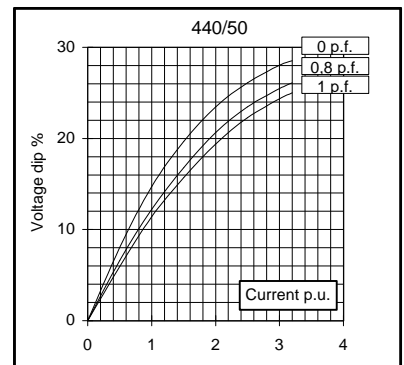
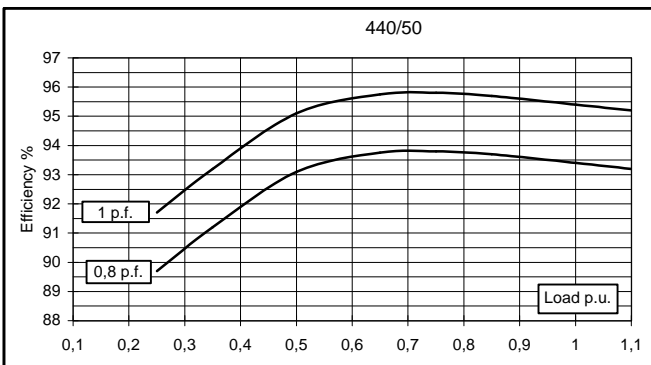
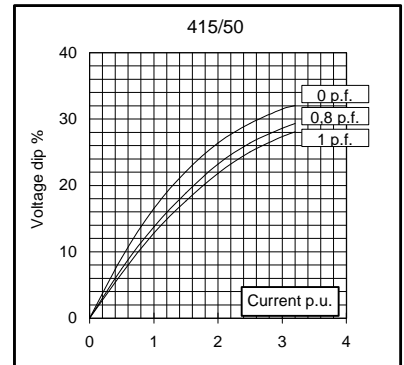
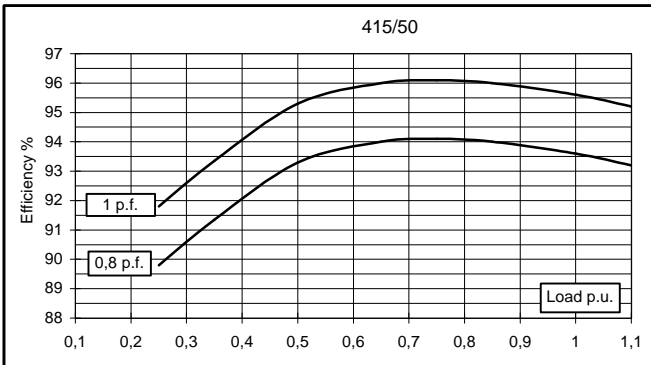
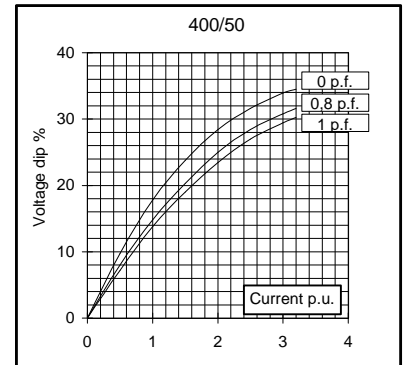
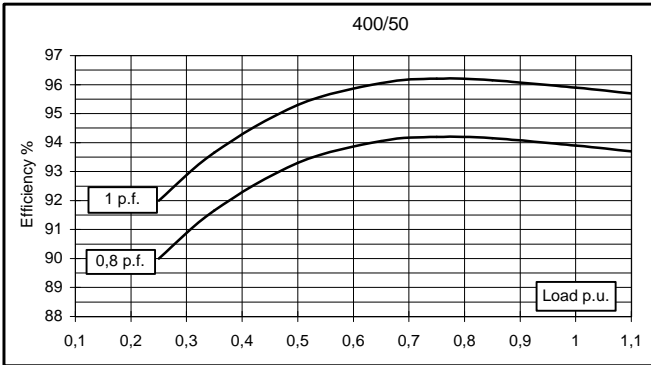
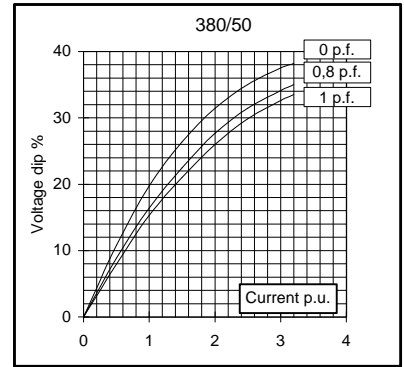
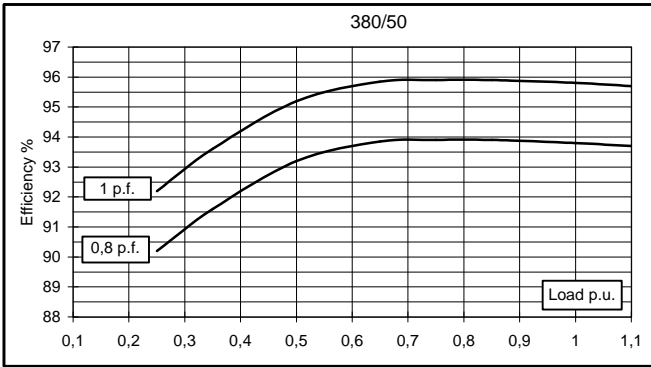

This document is a propriety of Mecc Alte S.p.a.. All rights reserved.

60 Hz
FAMCO
هایپر صنعت

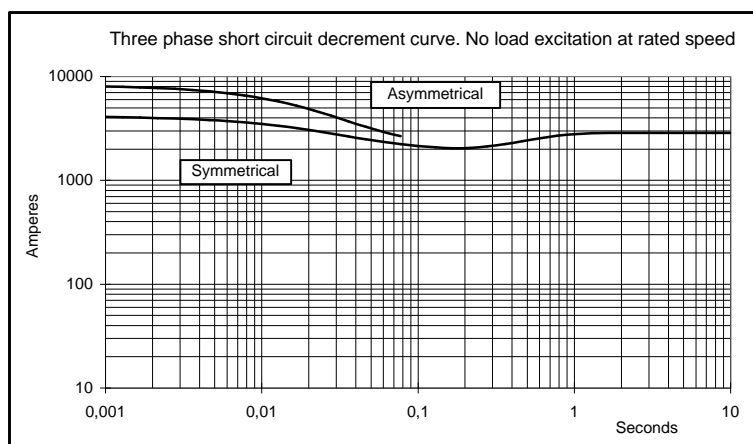
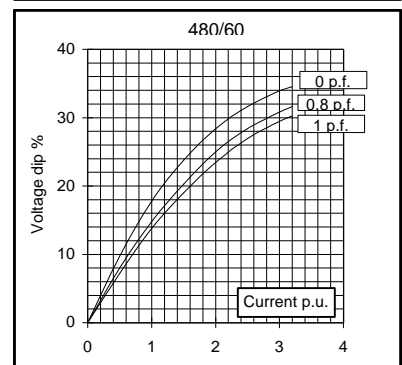
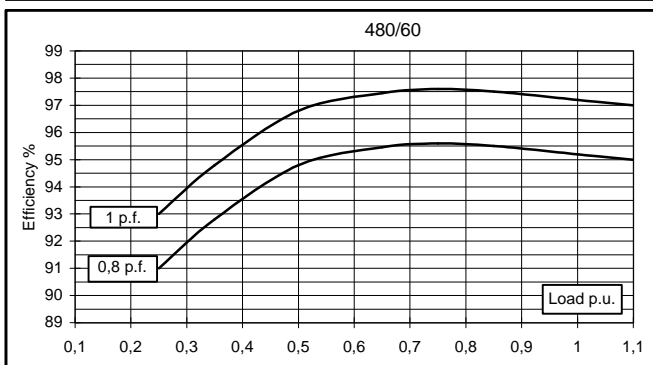
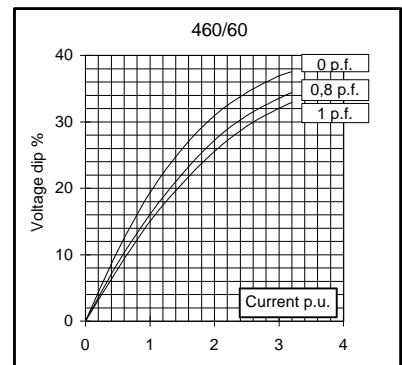
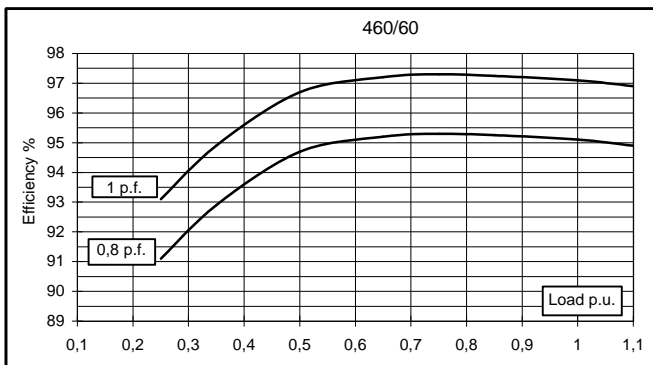
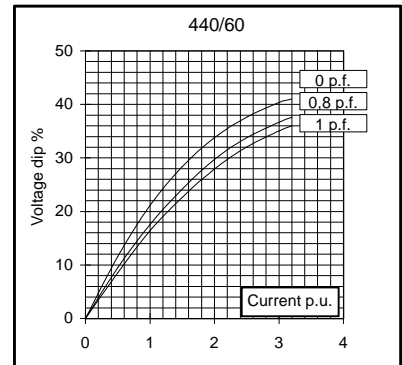
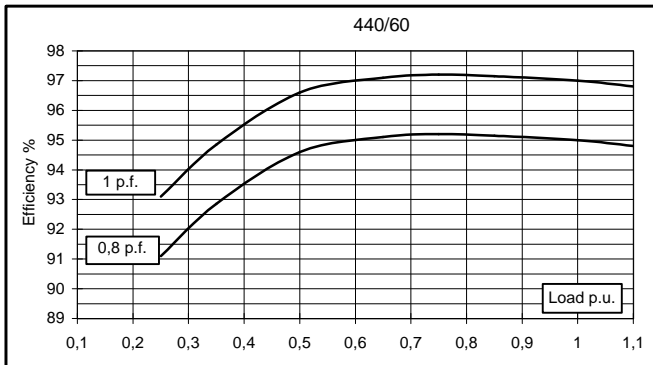
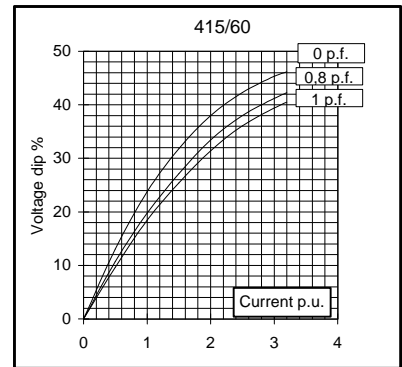
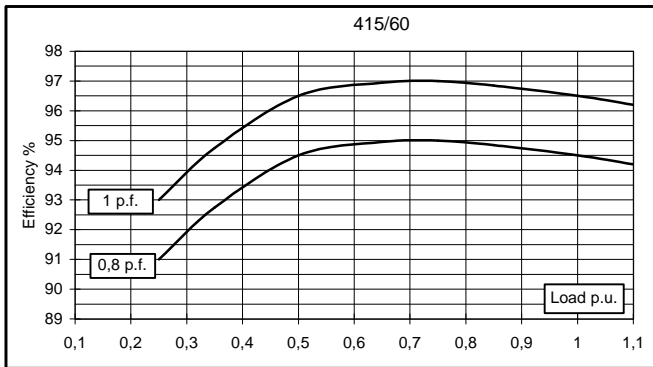

TWO BEARING MOMENTS OF INERTIA

FAMCO
هایپرمنت

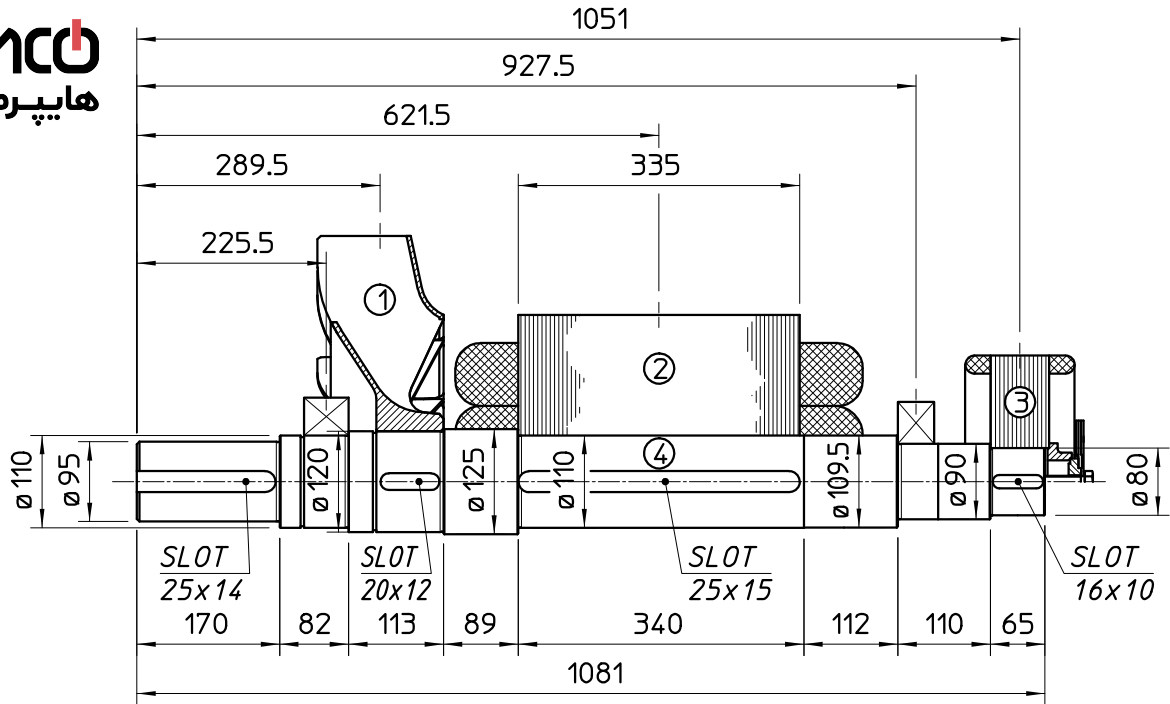

COMPONENT	WEIGHT kg	J kgm ²
1 FAN	16	0.550
2 MAIN ROTOR	274.6	5.846
3 EX. ROTOR	35	0.562
4 SHAFT	75	0.109
TOTAL	400.6	7.067

FAMCO
هایپرمنت

TWO BEARING DIMENSIONS

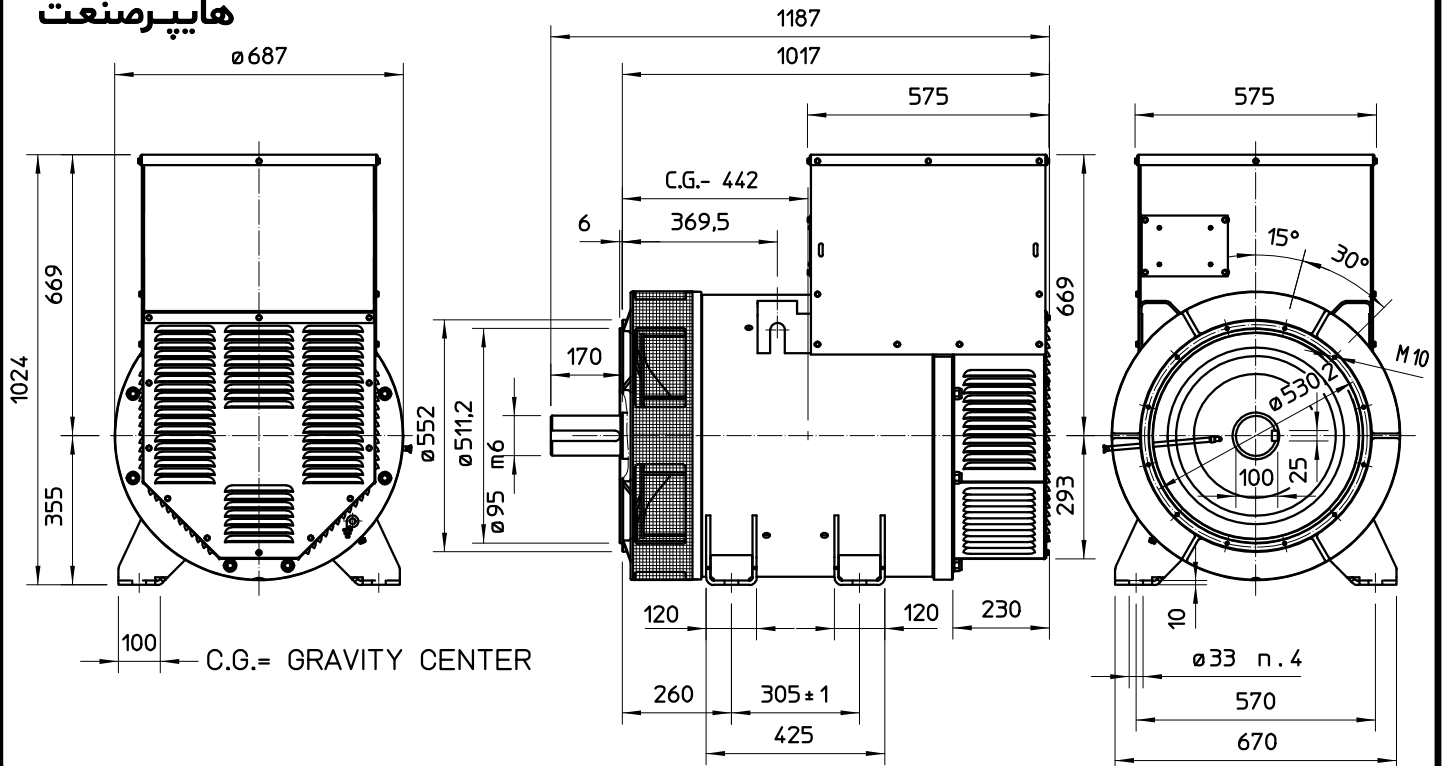

SINGLE BEARING MOMENTS OF INERTIA

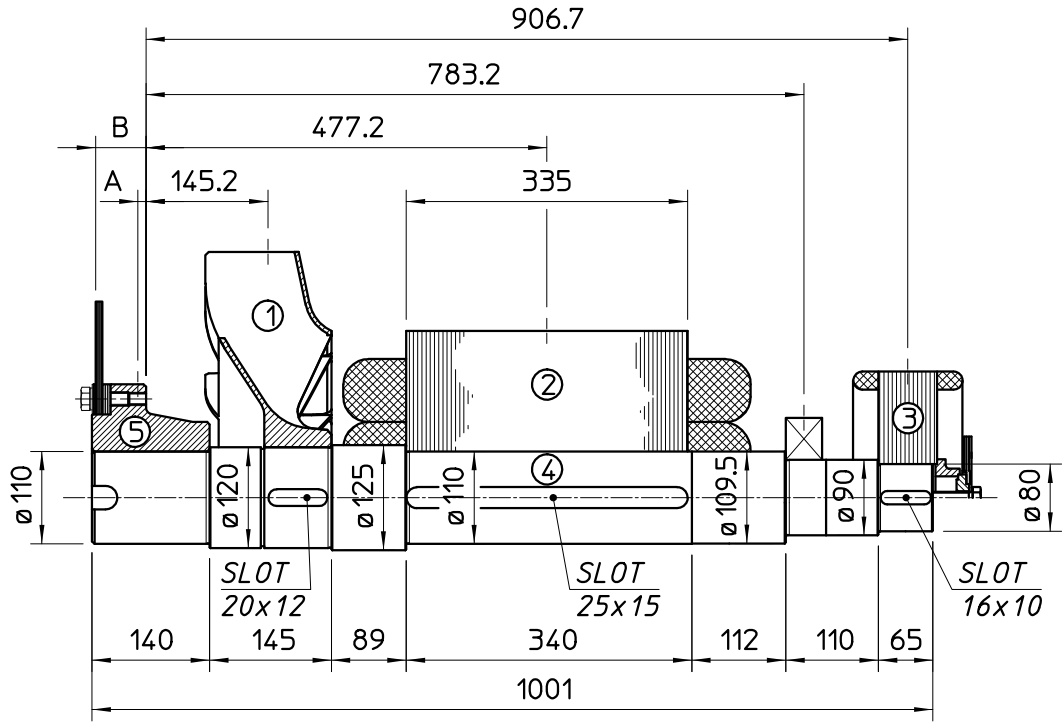

COMPONENT	WEIGHT kg	J kgm ²
1 FAN	16	0.550
2 MAIN ROTOR	274.6	5.846
3 EX. ROTOR	35	0.562
4 SHAFT	72.7	0.106
TOTAL	398.3	7.064

SAE No	SHAFTS COUPLING FLEX PLATE			
	A	B	WEIGHT kg	J kgm ²
14	9,6	60	41,4	0,511
18	6,6	50	45,1	0,858



SINGLE BEARING DIMENSIONS

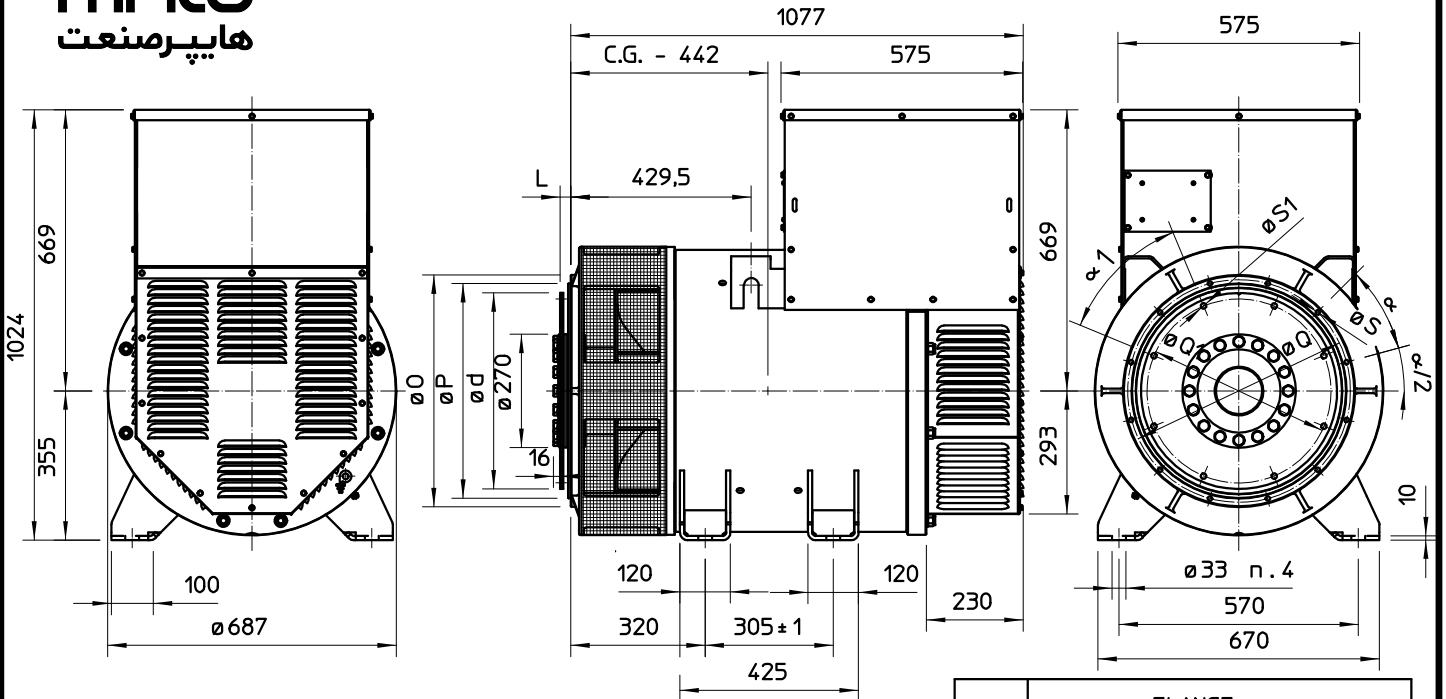

SAE N.	DISC COUPLING					
	L	d	Q1	N. FORI	S1	Q1
14	25,4	466,72	438,15	8	14	45°
18	15,7	571,5	542,92	6	17	60°

SAE N.	FLANGE					
	O	P	Q	N. FORI	S	Q1
1	552	511,2	530,2	12	11	15°
1/2	648	584,2	619,1	12	14	15°
0	711	647,7	679,5	16	14	11°15'
00	883	787,4	850,9	16	14	11°15'

C.G.= GRAVITY CENTER

Electrical Characteristics										
Frequency	Hz	50				60				
Voltage (parallel star)	V	380	400	415	440	415	440	460	480	
Rated power class H	kVA	450	450	450	360	480	510	540	540	
	kW	360	360	360	288	384	408	432	432	
Rated power class F	kVA	410	410	410	330	435	460	490	490	
	kW	328	328	328	264	348	368	392	392	
Regulation with	DER1	±1% with any power factor and speed variations between -5% +30%								
Insulation class		H								
Execution		Brushless								
Stator winding		12 ends								
Rotor		with damping cage								
Efficiencies class H	4/4	%	94,1	94,4	94,2	93,9	94,5	95	95,2	95,3
(see graph. for details)	3/4	%	94,3	94,6	94,5	94,1	94,6	95,1	95,3	95,5
	2/4	%	93,5	93,8	93,7	93,5	93,5	94	94,2	94,4
	1/4	%	89,4	89,5	89,4	89,2	90,6	90,9	91,1	91,2
Reactances (f. l.cl. F)	Xd	%	312	232	215	155	434	384	312	232
	Xd'	%	22,7	21,4	19,5	14,4	24,6	23,4	22,7	21,4
	Xd''	%	12,9	12,1	11	8,1	14,1	13,2	12,9	12,1
	Xq	%	122	107	101	71,7	147	132	122	107
	Xq'	%	122	107	101	71,7	147	132	122	107
	Xq''	%	29,1	27,4	25,2	18,4	31,7	30,2	29,1	27,4
	X ₂	%	18,2	17,6	16,4	11,8	20,2	19,4	18,2	17,6
	X ₀	%	3,6	3,1	2,9	2,1	4,1	3,9	3,6	3,1
Short Circuit Ratio	Kcc		0,32	0,43	0,46	0,64	0,23	0,26	0,32	0,43
Time Constants	Td'	sec.	0,13							
	Td''	sec.	0,019							
	Tdo'	sec.	2,70							
	Tα	sec.	0,03							
Short Circuit Current Capacity		%	>300				>350			
Excitation at no load	Amp.		0,4	0,6	0,8	1,6	0,3	0,4	0,5	0,6
Excitation at full load	Amp.		3,3	3,4	3,7	4,5	2,8	2,9	3	3,2
Overload (long-term)		%	1 hour in a 6 hours period 110% rated load							
Overload per 20 sec.		%	300							
Stator Winding Resistance (20°C)	Ω		0,013							
Rotor Winding Resistance (20°C)	Ω		4,881							
Exciter Resistance (20 °C)	Ω		Rotor : 0,317				Stator : 8,85			
Heat dissipation at f.l.cl.H	W		22572	21356	22166	18709	22349	21474	21782	21305
Telephone Interference			THF < 2%				TIF < 40			
Radio interference			EN61000-6-3, EN61000-6-2. For others standards apply to factory							
Waveform Distors.(THD) at f. load	LL/LN %		2,5 / 2,6							
Waveform Distors.(THD) at no load	LL/LN %		2,7 / 2,8							
Mechanical characteristics										
Protection			IP 21 (other protection on request)							
DE bearing			6322							
NDE bearing			6318.2RS							
Weight of wound stator assembly	kg		382							
Weight of wound rotor assembly	kg		245,8							
Weight of complete generator	kg		1118							
Maximun overspeed	rpm		2250							
Unbalanced magnetic pull at f.l.cl.F	kN/mm		5,9							
Cooling air requirement	m ³ /min		54				64,8			
Inertia Constant (H)	sec.		0,177				0,213			
Noise level at 1m/7m	dB(A)		94 / 82				98 / 88			

50 Hz

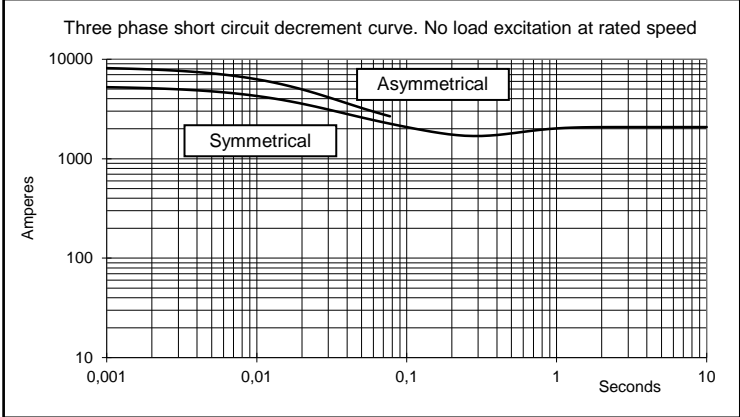
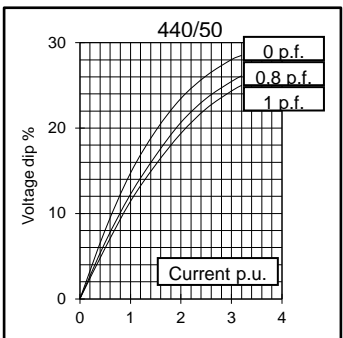
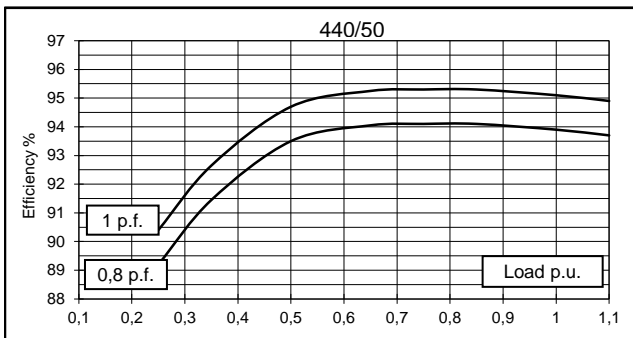
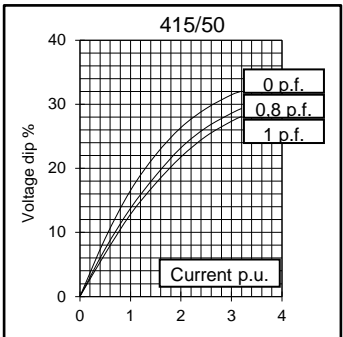
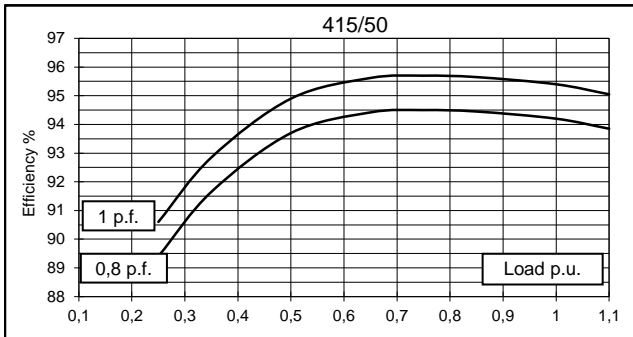
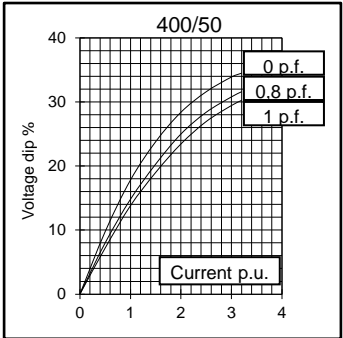
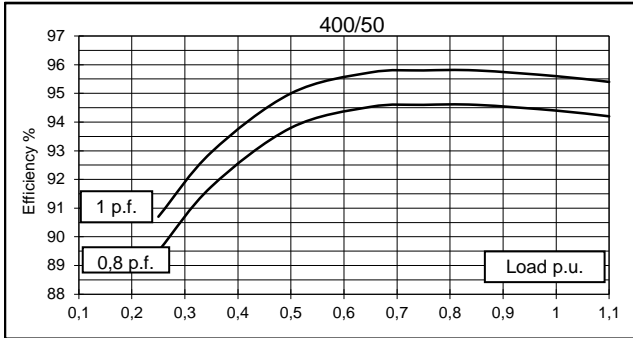
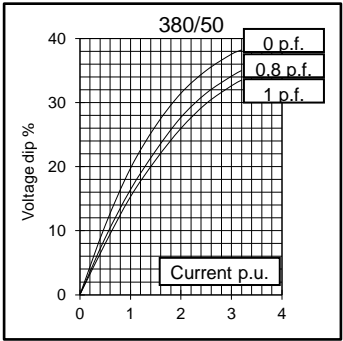
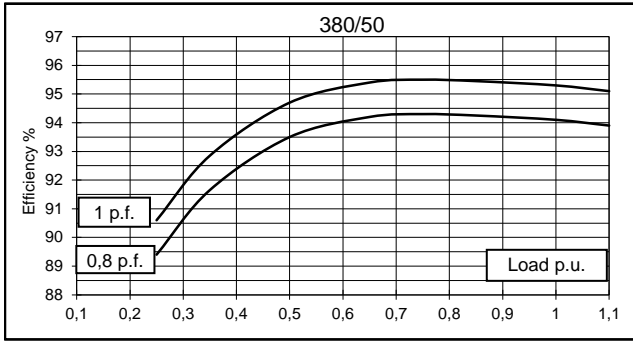

This document is a propriety of Mecc Alte S.p.A.. All rights reserved.

60 Hz

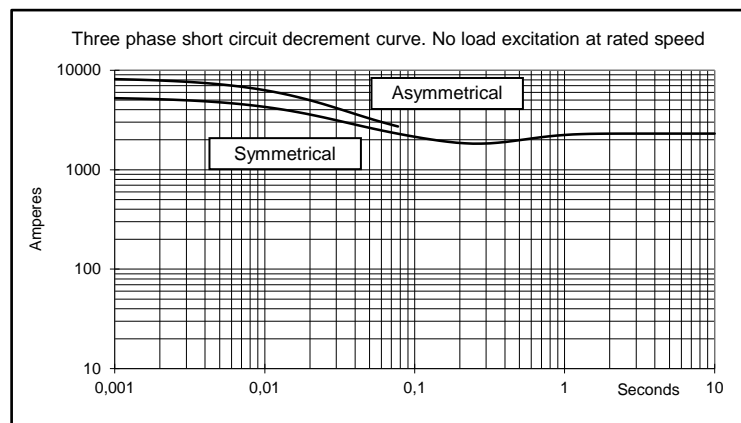
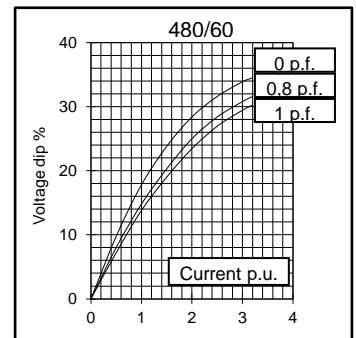
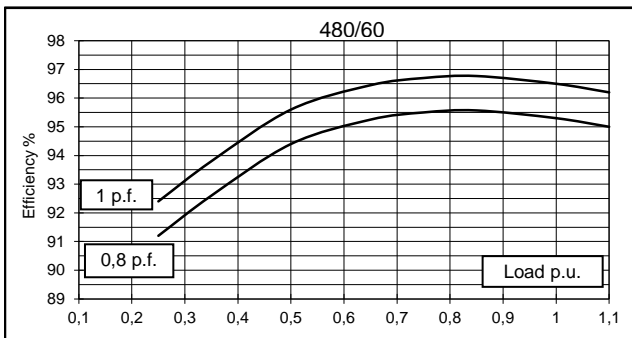
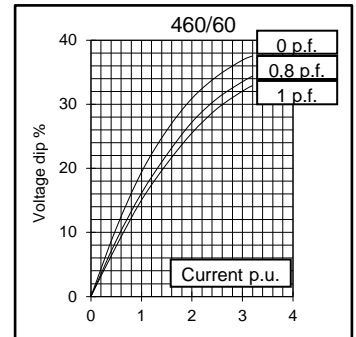
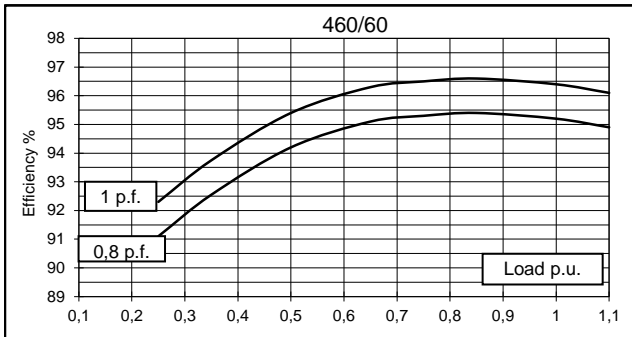
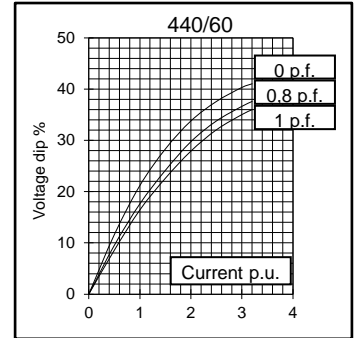
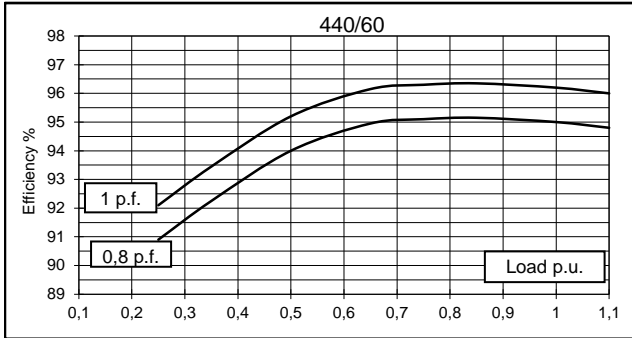
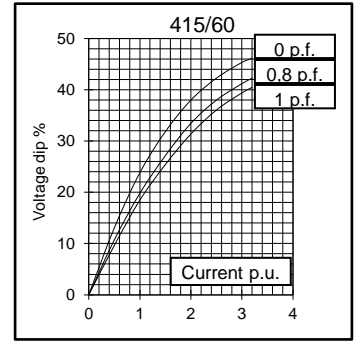
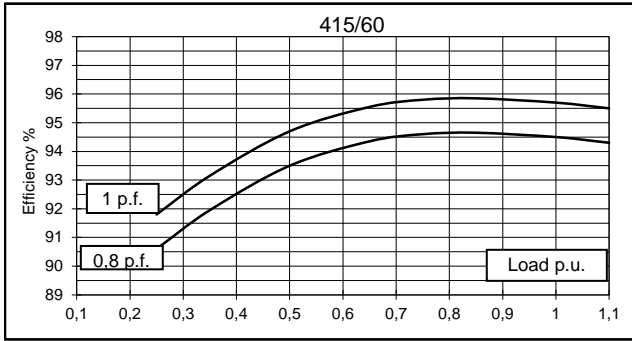

This document is a propriety of Mecc Alte S.p.A.. All rights reserved.

TWO BEARING MOMENTS OF INERTIA

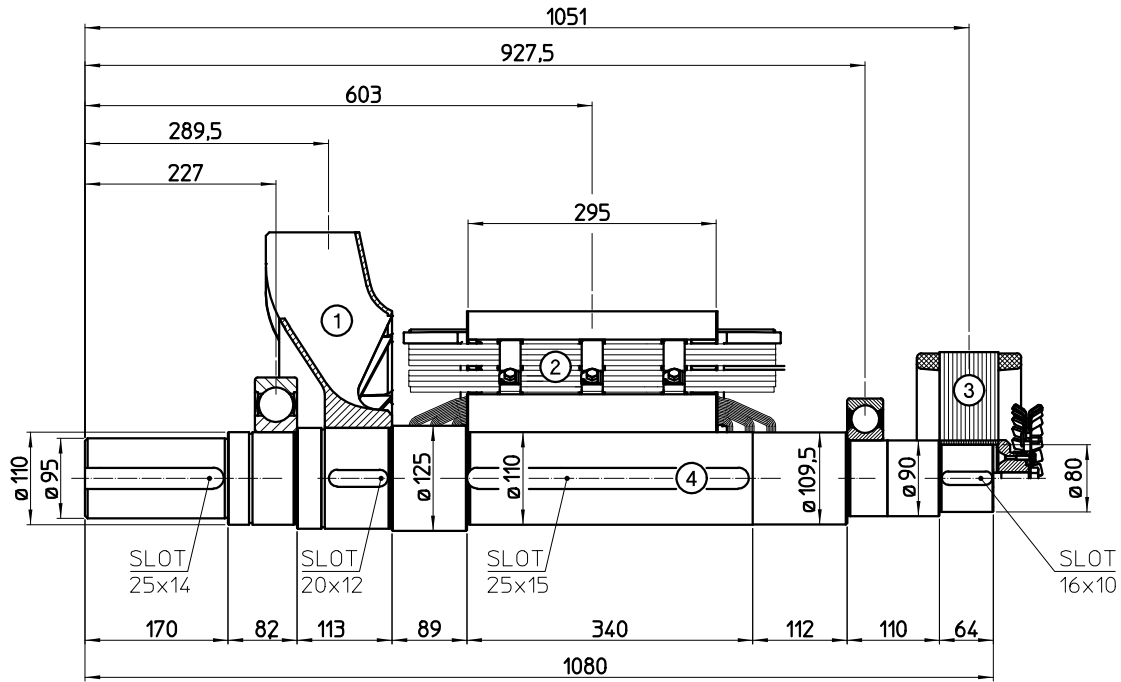

COMPONENT	WEIGHT kg	J kgm ²
1 FAN	10,2	0,335
2 MAIN ROTOR	245,8	5,234
3 EX. ROTOR	35	0,562
4 SHAFT	73,6	0,109
TOTAL	364,6	6,24



TWO BEARING DIMENSIONS

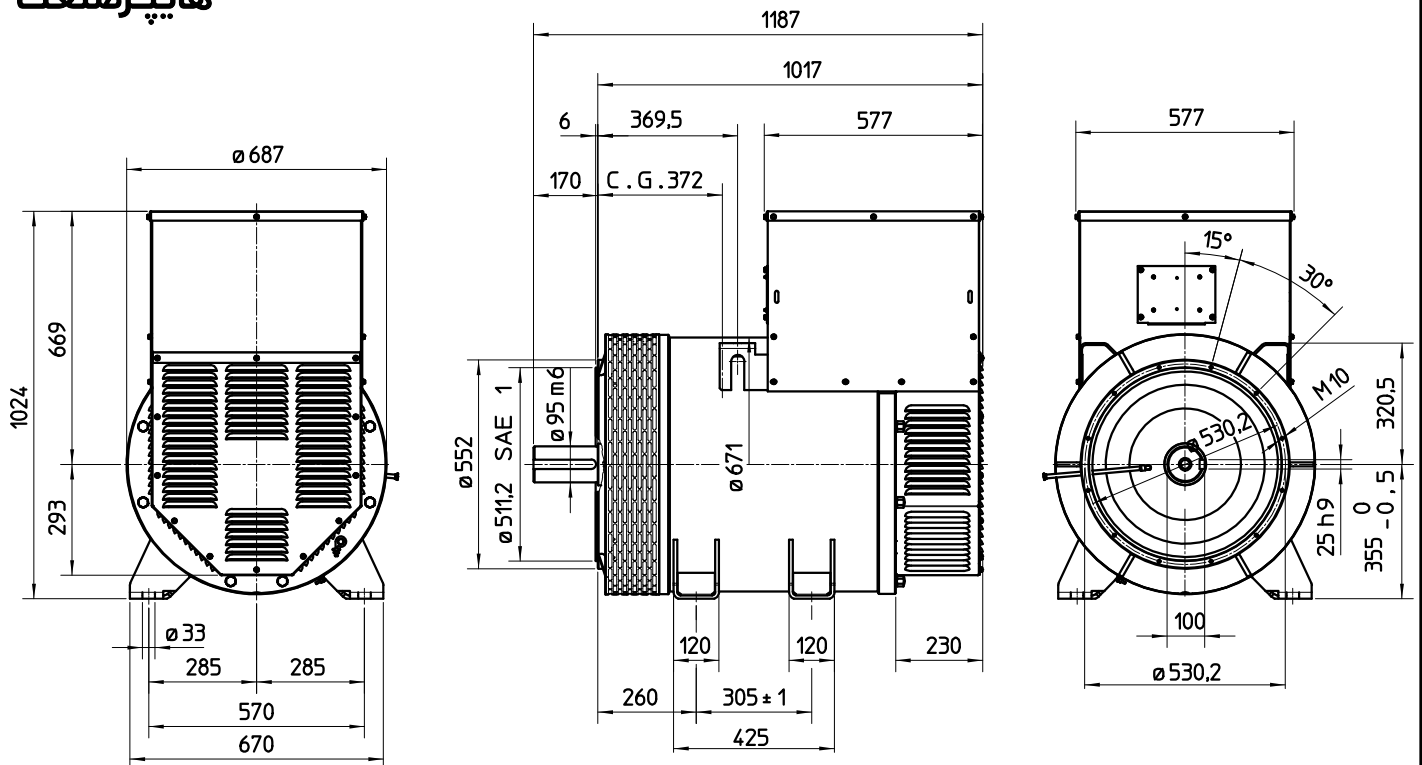

C.G.= GRAVITY CENTER

SINGLE BEARING MOMENTS OF INERTIA

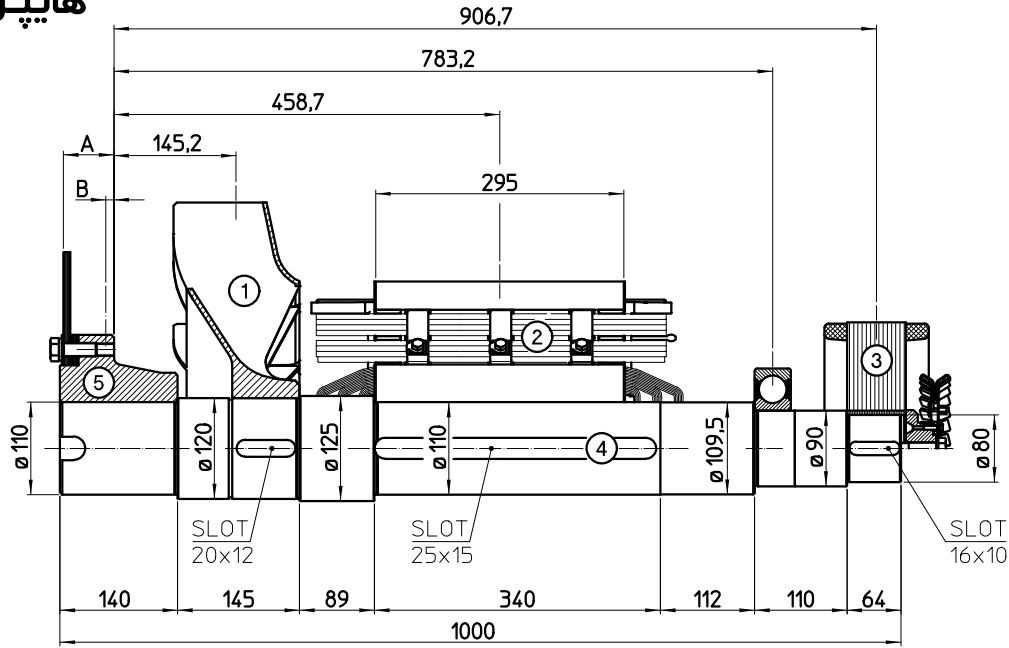

COMPONENT	WEIGHT kg	J kgm ²
1 FAN	10,2	0,335
2 MAIN ROTOR	245,8	5,234
3 EX. ROTOR	35	0,562
4 SHAFT	72	0,111
TOTAL	363	6,242

Sae No	SHAFTS COUPLING FLEX PLATE		
	A	B	WEIGHT kg
14	60	9,6	41,4
18	50	6,6	45,1

SINGLE BEARING DIMENSIONS

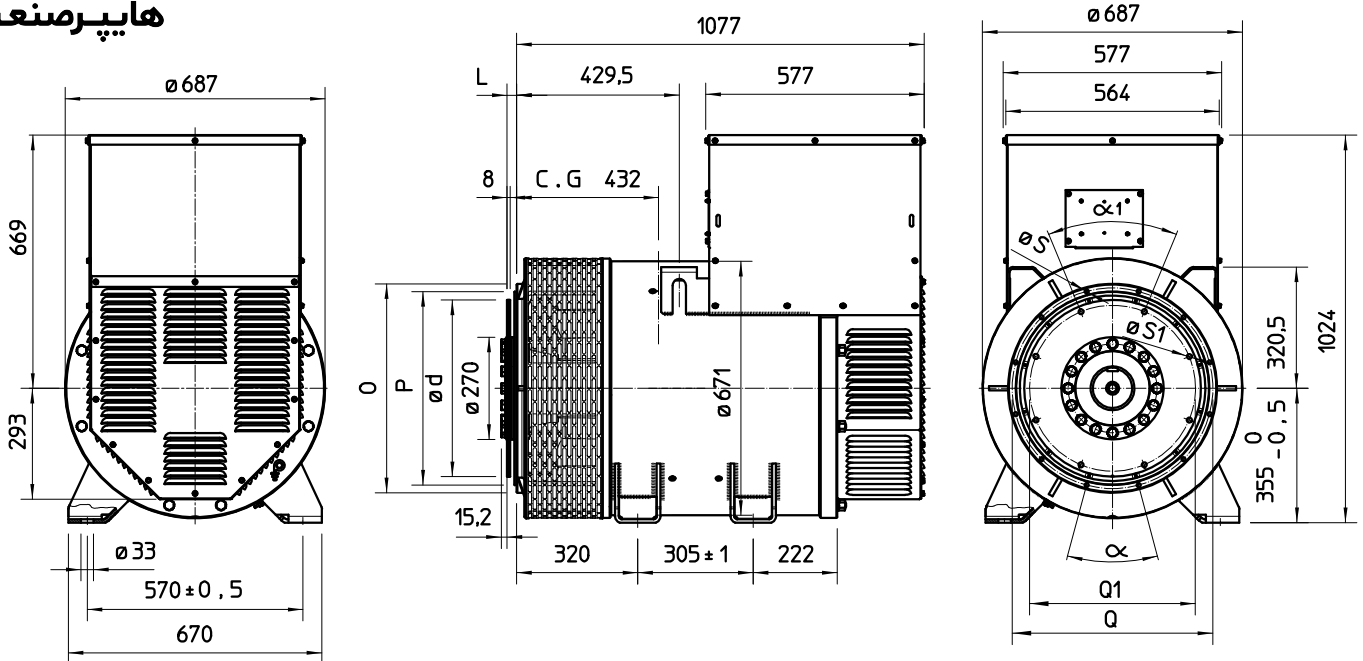

SAE N.	FLANGIA / FLANGE BRIDE / FLANSCH					
	O	P	Q	N. FORI	S	α
1	552	511,2	530,2	12	11	30°
1/2	648	584,2	619,1	12	14	30°
0	711	647,7	679,5	16	14	22,5°
00	883	787,4	850,9	16	14	22,5°

VOL. N.	GIUNTI A DISCHI / DISC COUPLING DISQUE DE MONOPALIER / SCHEIBENKUPPLUNG					
	L	d	Q1	N. FORI	S1	α1
14	25,4	466,72	438,15	8	14	45°
18	15,7	571,5	542,92	6	17	60°

Electrical Characteristics										
Frequency	Hz	50				60				
Voltage (series star)	V	380	400	415	440	415	440	460	480	
Rated power class H	kVA	30	30	28	/	33	36	36	36	
	kW	24	24	22,4	/	26,4	28,8	28,8	28,8	
Rated power class F	kVA	26	26	25	/	29	32	32	32	
	kW	20,8	20,8	20	/	23,2	25,6	25,6	25,6	
Regulation with	SR7/2	±1,5 % with any power factor and speed variations between -5% +30%								
Insulation class		H								
Execution		Brushless								
Stator winding		12 ends								
Rotor		without damping cage								
Efficiencies class H	4/4	%	87,7	88,1	88,4	/	88,9	89,2	89,4	89,8
(see graph. for details)	3/4	%	88,2	88,5	88,6	/	89,7	89,9	90,1	90,3
	2/4	%	86,4	86,5	86,5	/	88,1	88,2	88,3	88,4
	1/4	%	84,2	84	84	/	86,1	86,1	86	85,9
Reactances (f. l.cl. F)	Xd	%	182,8	165	143,1	/	202,3	196,4	179,7	165
	Xd'	%	17,06	15,4	13,35	/	18,89	18,33	16,77	15,4
	Xd''	%	9,75	8,8	7,63	/	10,79	10,47	9,58	8,8
	Xq	%	78,7	71	61,6	/	87,1	84,5	77,3	71
	Xq'	%	78,7	71	61,6	/	87,1	84,5	77,3	71
	Xq''	%	21,1	19	16,5	/	23,3	22,6	20,7	19
	X ₂	%	14,63	13,2	11,45	/	16,19	15,71	14,37	13,2
	X ₀	%	3,10	2,8	2,43	/	3,43	3,33	3,05	2,8
Short Circuit Ratio	Kcc		0,55	0,62	0,68	/	0,38	0,44	0,55	0,62
Time Constants	Td'	sec.	0,046							
	Td''	sec.	0,012							
	Tdo'	sec.	0,93							
	T _α	sec.	0,011							
Short Circuit Current Capacity		%	>300				>350			
Excitation at no load	Amp.		0,4	0,6	0,8	/	0,35	0,4	0,5	0,55
Excitation at full load	Amp.		1,75	1,96	2,1	/	1,5	1,6	1,8	1,9
Overload (long-term)		%	1 hour in a 6 hours period 110% rated load							
Overload per 20 sec.		%	300							
Stator Winding Resistance (20°C)	Ω		0,106							
Rotor Winding Resistance (20°C)	Ω		1,86							
Exciter Resistance (20 °C)	Ω		Rotor : 0,64				Stator : 10,60			
Heat dissipation at f.l.cl.H	W		3366	3242	2939	/	3296	3487	3415	3271
Telephone Interference			FHT < 2%				TIF < 45			
Radio interference			EN60034-1. For others standards apply to factory							
Waveform Distors.(THD) at f. load	LL/LN %		2,1 / 2							
Waveform Distors.(THD) at no load	LL/LN %		3,3 / 3,1							
Mechanical characteristics										
Protection			IP 23 (other protection on request)							
DE bearing			6309.2RS							
NDE bearing			6207.2RS							
Weight of wound stator assembly	kg		57							
Weight of wound rotor assembly	kg		32,4							
Weight of complete generator	kg		155							
Maximun overspeed	rpm		2250							
Unbalanced magnetic pull at f.l.cl.F	kN/mm		4,7							
Cooling air requirement	m ³ /min		5,3				5,8			
Inertia Constant (H)	sec.		0,068				0,081			
Noise level at 1m/7m	dB(A)		68 / 57				71 / 61			

All technical data are to be considered as a reference and they can be modified without any notice

This document is a propriety of Mecc Alte S.p.a..All rights reserved.

50 Hz

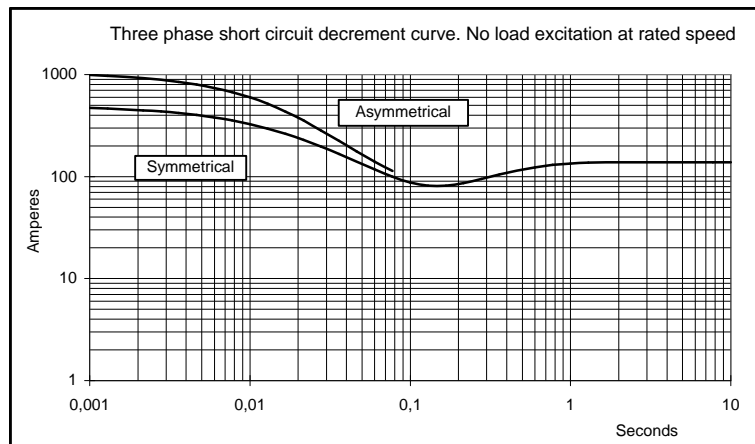
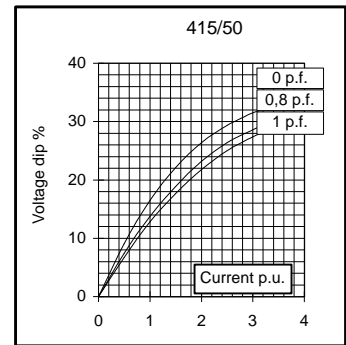
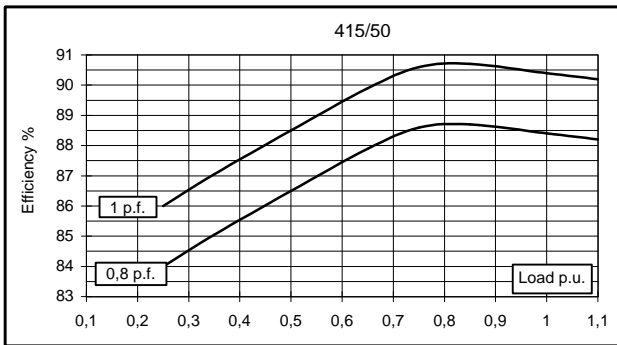
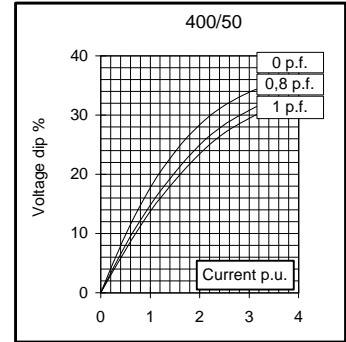
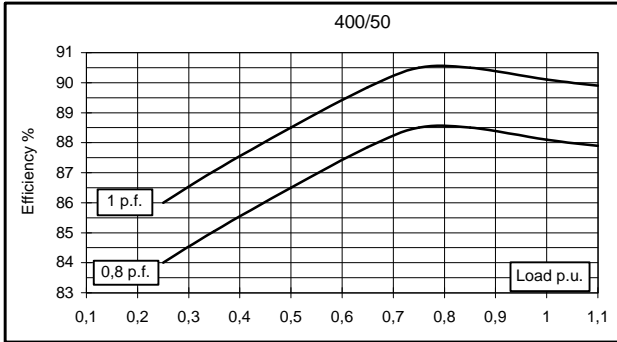
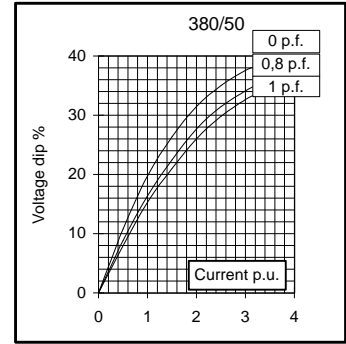
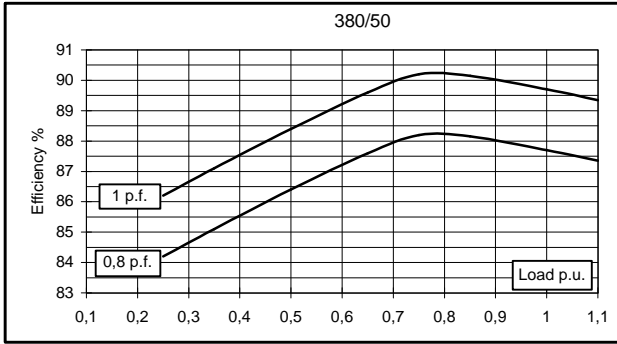

This document is a propriety of Mecc Alte S.p.a.. All rights reserved.

60 Hz

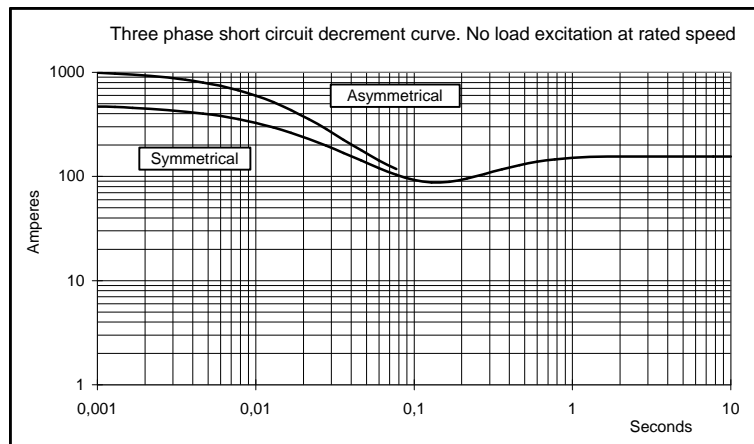
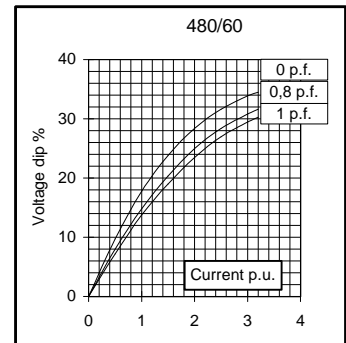
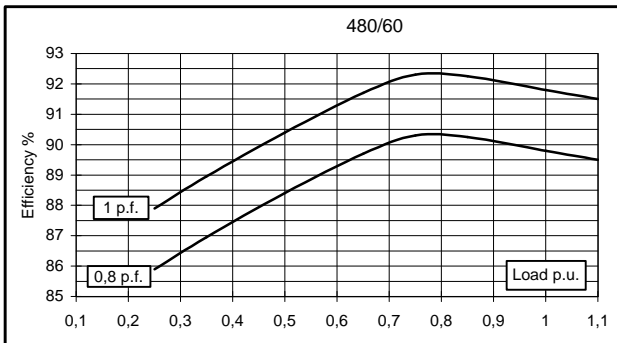
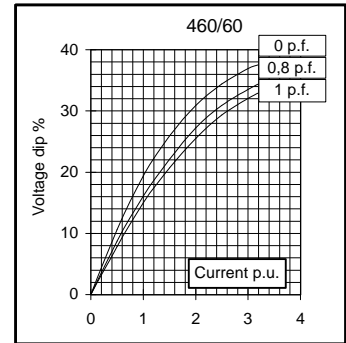
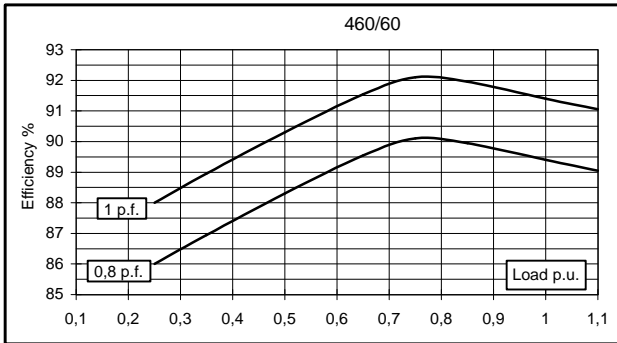
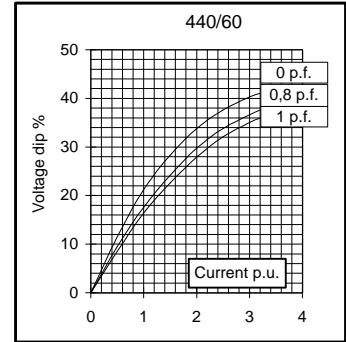
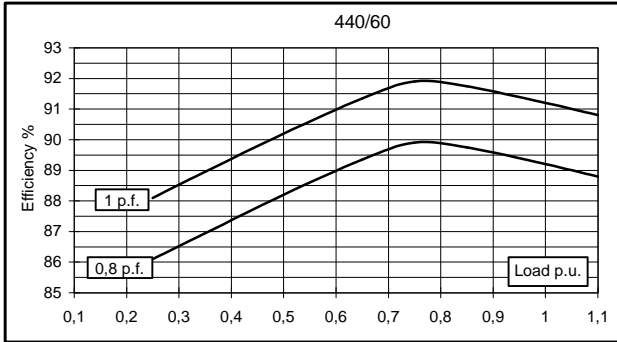
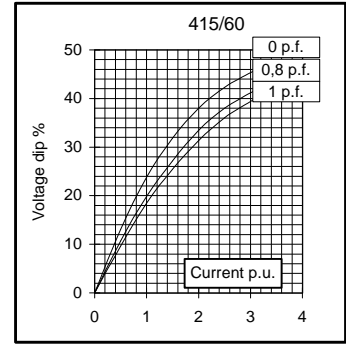
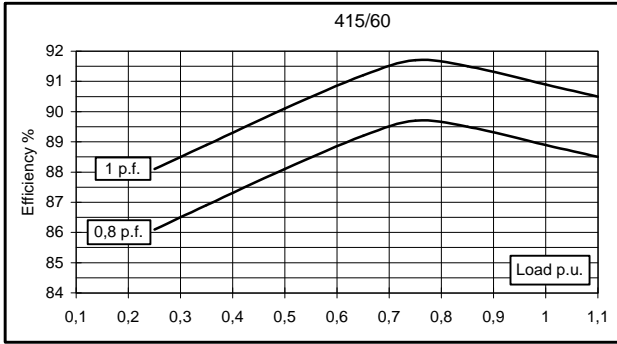

This document is a propriety of Mecc Alte S.p.a.. All rights reserved.

TWO BEARING MOMENTS OF INERTIA

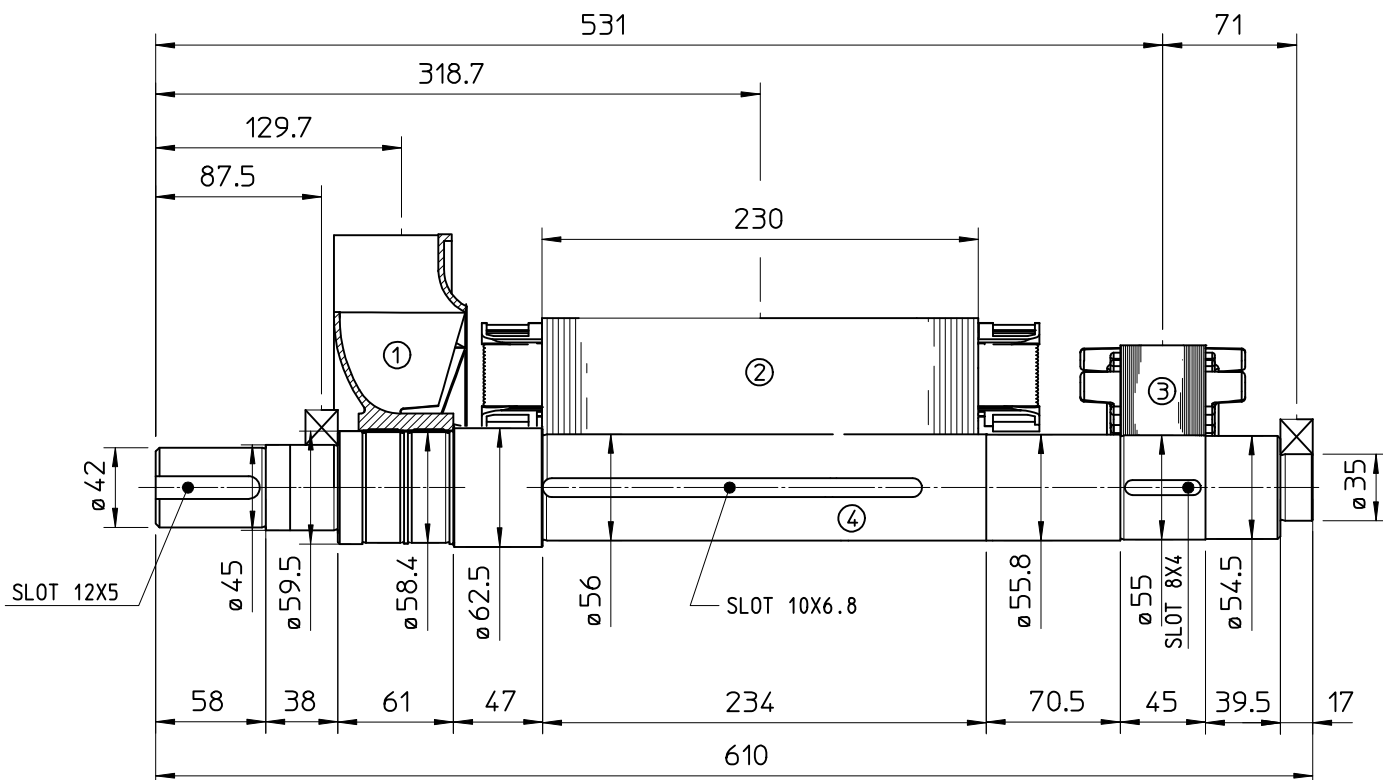

FAMCO
هایپرمنت

COMPONENT	WEIGHT Kg	J Kg ^m ²
1 FAN	1.2	0.0102
2 MAIN ROTOR	32.4	0.138
3 EX ROTOR	5.4	0.012
4 SHAFT	11.3	0.0043
6 TOTAL	50.3	0.1645

TWO BEARING DIMENSIONS

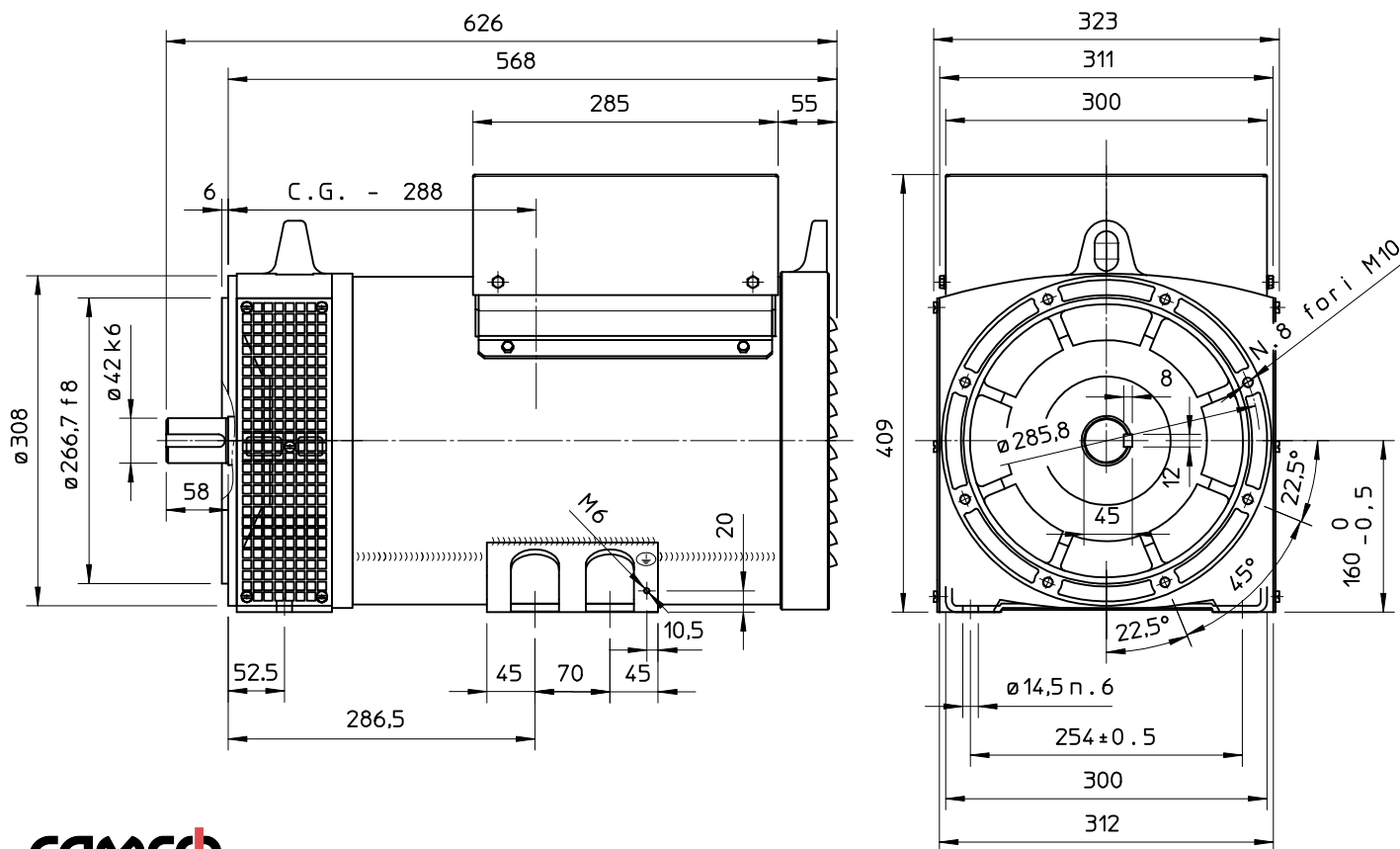

FAMCO
هایپرمنت

C.G. = GRAVITY CENTER

SINGLE BEARING MOMENTS OF INERTIA

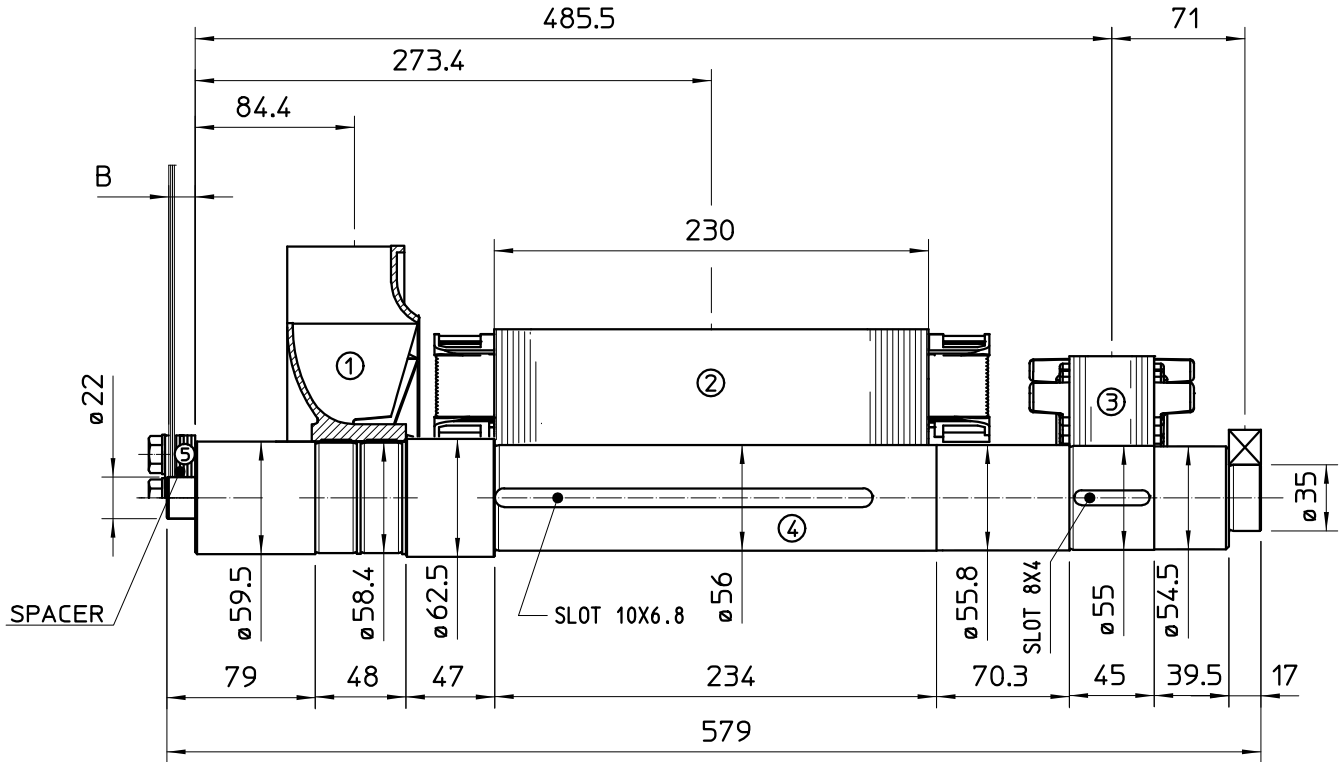

COMPONENT	WEIGHT Kg	J Kg ^{m²}
1 FAN	1.2	0.0102
2 MAIN ROTOR	32.4	0.138
3 EX ROTOR	5.4	0.012
4 SHAFT	11.2	0.0044
6 TOTAL	50.2	0.1646

SAE N.	5	SHAFT COUPLING FLEX PLATE	
	B (mm)	WEIGHT kg	J kg ^{m²}
6 1/2	4	1.14	0.0067
7 1/2	4	1.42	0.0103
8	35.6	1.97	0.0171
10	27.6	2.59	0.0319
11 1/2	14	3.1	0.0481

SINGLE BEARING DIMENSIONS

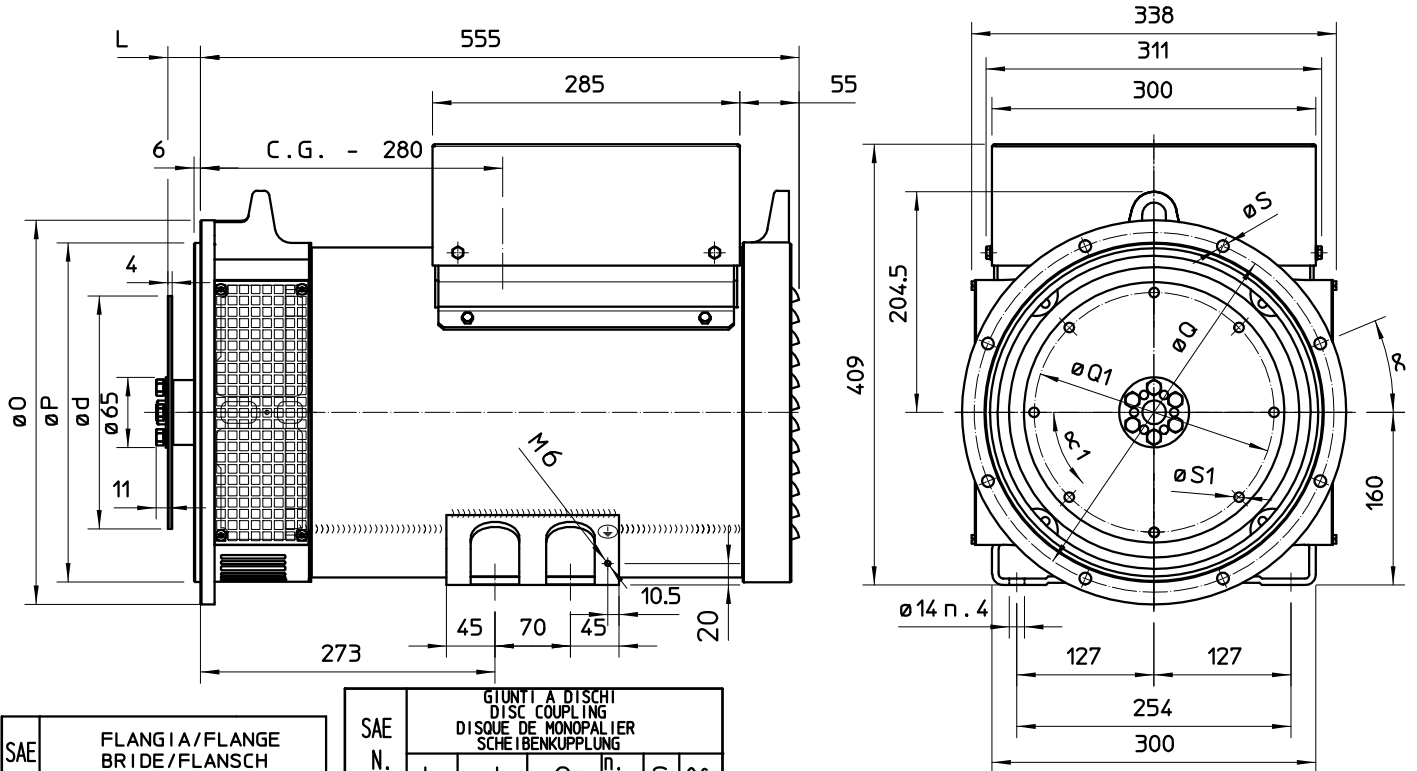

SAE N.	FLANGIA/FLANGE BRIDE/FLANSCH					
	O	P	Q	n. fori	S	α
5	356	314.3	333.4	8	11	22°30'
4	403	362	381	12	11	15°
3	451	409.6	428.6	12	11	15°
2	489	447.7	466.7	12	11	15°

SAE N.	GIUNTI A DISCHI DISC COUPLING DISQUE DE MONOPALIER SCHEIBENKUPPLUNG					
	L	d	Q1	n. fori	S1	α1
6 1/2	30.2	215.9	200	6	9	60°
7 1/2	30.2	241.3	222.25	8	9	45°
8	62	263.52	244.47	6	11	60°
10	53.8	314.32	295.27	8	11	45°
11 1/2	39.6	352.42	333.37	8	11	45°

C.G. = GRAVITY CENTER

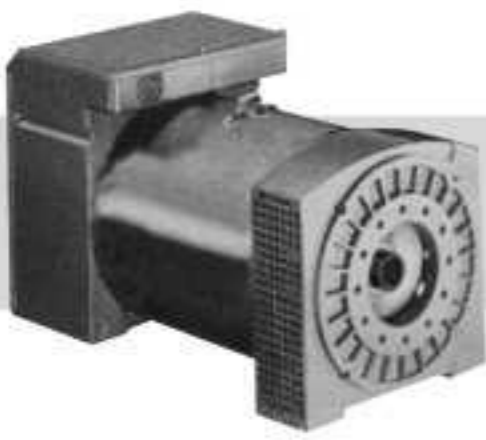

meccalte

COMPANY
WITH QUALITY SYSTEM
CERTIFIED BY DNV
ISO 9001

BTO3

MECCALTE spa - Via Roma, 20 - 36051 CREAZZO (VI) ITALIA
Tel. 0444/396111 - Fax 0444/396166 - e-mail : mecc-alte-spa@meccalte.it
web site: www.meccalte.com

3 PHASE 4 POLE IP 23

CARATTERISTICHE / CHARACTERISTICS / CARACTERISTIQUES / TECHNISCHE MERKMALE / CARACTERISTICAS

POTENZE 230/400 V A 1500 giri/min - 50 Hz		POWER 230/400 V AT 1500 RPM - 50 Hz		PUISSANCE 230/400 V A 1500 T/min - 50 Hz		LEISTUNG 230/400 V BEI 1500 UpM - 50 Hz		POTENCIAS 230/400 V A 1500 RPM - 50 Hz			
Tipo Type Type Typ Tipo	CL. H ($\Delta T=125^{\circ}\text{C}$)			CL. F ($\Delta T=105^{\circ}\text{C}$)			CL. H ($\Delta T=125^{\circ}\text{C}$)			T.H.D. %	
	TRIFASE / THREE-PHASE TRIPHASE DREIPHASIG / TRIFASICO		CAPACITA' DI SPUNTO PICKUP CAPACITY CAPACITE DE DEMARRAGE ANLEISTUNG CAPACIDAD DE ARRANQUE	TRIFASE / THREE-PHASE TRIPHASE DREIPHASIG / TRIFASICO		RENDIMENTI / EFFICIENCY RENDEMENT / WIRKUNGSGRAD RENDIMIENTOS			MONOFASE / SINGLE-PHASE MONOPHASE / EINPHASIG / MONOFASICO DELTA CONNECTION		
	KVA	KW COS φ 0,8		KVA	KW COS φ 0,8	2/4 %	3/4 %	4/4 %	KVA		CAPACITA' DI SPUNTO PICKUP CAPACITY CAPACITE DE DEMARRAGE ANLEISTUNG CAPACIDAD DE ARRANQUE
BTO3-1S/4	7	5,6	KVA 32,5	6,5	5,2	76	80	79,5	5	KVA 24	< 3,5
BTO3-2S/4	9	7,2	KVA 40	8	6,4	78	82	81,3	6,5	KVA 30	< 3,5
BTO3-1L/4	11	8,8	KVA 50	10	8	82	84,2	84	8	KVA 38	< 3,5
BTO3-2L/4	13	10,4	KVA 62,5	12	9,6	83	85	84	9,5	KVA 45	< 3,5
BTO3-3L/4	15	12	KVA 65	14	11,2	84	85,5	84,5	11	KVA 50	< 3,5

POTENZE 277/480 V A 1800 giri/min - 60 Hz		POWER 277/480 V AT 1800 RPM - 60 Hz		PUISSANCE 277/480 V A 1800 T/min - 60 Hz		LEISTUNG 277/480 V BEI 1800 UpM - 60 Hz		POTENCIAS 277/480 V A 1800 RPM - 60 Hz			
Tipo Type Type Typ Tipo	CL. H ($\Delta T=125^{\circ}\text{C}$)			CL. F ($\Delta T=105^{\circ}\text{C}$)			CL. H ($\Delta T=125^{\circ}\text{C}$)			T.H.D. %	
	TRIFASE / THREE-PHASE TRIPHASE DREIPHASIG / TRIFASICO		CAPACITA' DI SPUNTO PICKUP CAPACITY CAPACITE DE DEMARRAGE ANLEISTUNG CAPACIDAD DE ARRANQUE	TRIFASE / THREE-PHASE TRIPHASE DREIPHASIG / TRIFASICO		RENDIMENTI / EFFICIENCY RENDEMENT / WIRKUNGSGRAD RENDIMIENTOS			MONOFASE / SINGLE-PHASE MONOPHASE / EINPHASIG / MONOFASICO DELTA CONNECTION		
	KVA	KW COS φ 0,8		KVA	KW COS φ 0,8	2/4 %	3/4 %	4/4 %	KVA		CAPACITA' DI SPUNTO PICKUP CAPACITY CAPACITE DE DEMARRAGE ANLEISTUNG CAPACIDAD DE ARRANQUE
BTO3-1S/4	8,4	6,7	KVA 39	7,8	6,2	77,5	81,5	81	6	KVA 28	< 3,5
BTO3-2S/4	10,8	8,6	KVA 48	9,6	7,7	79,2	83,1	82,7	7,8	KVA 36	< 3,5
BTO3-1L/4	13,2	10,6	KVA 60	12	9,6	83	85,6	85,4	9,6	KVA 45	< 3,5
BTO3-2L/4	15,6	12,5	KVA 75	14,4	11,5	83,5	85,7	85,5	11,4	KVA 54	< 3,5
BTO3-3L/4	18	14,4	KVA 78	16,8	13,4	85	87	86	13,2	KVA 60	< 3,5

Tipo Type Type Typ Tipo	J (Kgm ²)			Peso/Weight Poids/Gewicht (Kg)			Vol. d'aria / Air Vol. / Vol. d'air Luftmenge / Vol. de aire (m ³ /min)		Rumore - Noise - Bruit Gerausch - Ruido dB(A)				GIUNTO A DISCHI COUPLING DISCS DISQUE DE MENOPALIER SCHEIBENKUPPLUNG JUNTA A DISCOS	
	B3/B14	B3/B9	MD35	B3/B14	B3/B9	MD35	50HZ	60HZ	50 Hz		60 Hz		SAE N°	J(kgm ²)*
									1m	7m	1m	7m		
BTO3-1S/4	0,0445	0,0444	0,0447	53	51	57	4,2	5,1	72	58	78	60	6 1/2	0,0067
BTO3-2S/4	0,0545	0,0544	0,0547	59	57	63	4,1	5					7 1/2	0,0103
BTO3-1L/4	0,0657	0,0656	0,0658	69	67	73	4	5					8	0,0171
BTO3-2L/4	0,0717	0,0716	0,0718	74	72	78	3,9	4,9					10	0,0319
BTO3-3L/4	0,0817	0,0816	0,0818	79	77	83	3,9	4,9					11 1/2	0,0481

* Il valore totale J della forma MD35 si ottiene sommando il J della forma MD35 con quello del giunto a dischi SAE prescelto.

The J value of form MD35 is obtained by summing the J of the MD35 form with the J of the chosen SAE coupling discs.

La valeur de la form MD35 est obtenue en sommant le J de la form MD35 avec celui du disque de monopulier SAE.

Der Wert J der Form MD35 wird durch die Summe von J der Form MD35 und J der ausgewählten SAE Scheibenkupplung erreicht.

El valor J de la forma MD35 se obtiene sumando el J forma MD35 con la de la junta a discos SAE seleccionada.



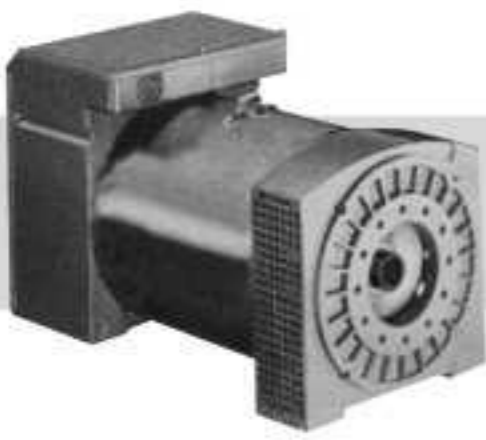

meccalte

COMPANY
WITH QUALITY SYSTEM
CERTIFIED BY DNV
ISO 9001

BTO3

MECCALTE spa - Via Roma, 20 - 36051 CREAZZO (VI) ITALIA
Tel. 0444/396111 - Fax 0444/396166 - e-mail : mecc-alte-spa@meccalte.it
web site: www.meccalte.com

3 PHASE 4 POLE IP 23

CARATTERISTICHE / CHARACTERISTICS / CARACTERISTIQUES / TECHNISCHE MERKMALE / CARACTERISTICAS

POTENZE 230/400 V A 1500 giri/min - 50 Hz		POWER 230/400 V AT 1500 RPM - 50 Hz		PUISSANCE 230/400 V A 1500 T/min - 50 Hz		LEISTUNG 230/400 V BEI 1500 UpM - 50 Hz		POTENCIAS 230/400 V A 1500 RPM - 50 Hz			
Tipo Type Type Typ Tipo	CL. H ($\Delta T=125^{\circ}\text{C}$)			CL. F ($\Delta T=105^{\circ}\text{C}$)			CL. H ($\Delta T=125^{\circ}\text{C}$)			T.H.D. %	
	TRIFASE / THREE-PHASE TRIPHASE DREIPHASIG / TRIFASICO		CAPACITA' DI SPUNTO PICKUP CAPACITY CAPACITE DE DEMARRAGE ANLEISTUNG CAPACIDAD DE ARRANQUE	TRIFASE / THREE-PHASE TRIPHASE DREIPHASIG / TRIFASICO		RENDIMENTI / EFFICIENCY RENDEMENT / WIRKUNGSGRAD RENDIMIENTOS			MONOFASE / SINGLE-PHASE MONOPHASE / EINPHASIG / MONOFASICO DELTA CONNECTION		
	KVA	KW COS φ 0,8		KVA	KW COS φ 0,8	2/4 %	3/4 %	4/4 %	KVA		CAPACITA' DI SPUNTO PICKUP CAPACITY CAPACITE DE DEMARRAGE ANLEISTUNG CAPACIDAD DE ARRANQUE
BTO3-1S/4	7	5,6	KVA 32,5	6,5	5,2	76	80	79,5	5	KVA 24	< 3,5
BTO3-2S/4	9	7,2	KVA 40	8	6,4	78	82	81,3	6,5	KVA 30	< 3,5
BTO3-1L/4	11	8,8	KVA 50	10	8	82	84,2	84	8	KVA 38	< 3,5
BTO3-2L/4	13	10,4	KVA 62,5	12	9,6	83	85	84	9,5	KVA 45	< 3,5
BTO3-3L/4	15	12	KVA 65	14	11,2	84	85,5	84,5	11	KVA 50	< 3,5

POTENZE 277/480 V A 1800 giri/min - 60 Hz		POWER 277/480 V AT 1800 RPM - 60 Hz		PUISSANCE 277/480 V A 1800 T/min - 60 Hz		LEISTUNG 277/480 V BEI 1800 UpM - 60 Hz		POTENCIAS 277/480 V A 1800 RPM - 60 Hz			
Tipo Type Type Typ Tipo	CL. H ($\Delta T=125^{\circ}\text{C}$)			CL. F ($\Delta T=105^{\circ}\text{C}$)			CL. H ($\Delta T=125^{\circ}\text{C}$)			T.H.D. %	
	TRIFASE / THREE-PHASE TRIPHASE DREIPHASIG / TRIFASICO		CAPACITA' DI SPUNTO PICKUP CAPACITY CAPACITE DE DEMARRAGE ANLEISTUNG CAPACIDAD DE ARRANQUE	TRIFASE / THREE-PHASE TRIPHASE DREIPHASIG / TRIFASICO		RENDIMENTI / EFFICIENCY RENDEMENT / WIRKUNGSGRAD RENDIMIENTOS			MONOFASE / SINGLE-PHASE MONOPHASE / EINPHASIG / MONOFASICO DELTA CONNECTION		
	KVA	KW COS φ 0,8		KVA	KW COS φ 0,8	2/4 %	3/4 %	4/4 %	KVA		CAPACITA' DI SPUNTO PICKUP CAPACITY CAPACITE DE DEMARRAGE ANLEISTUNG CAPACIDAD DE ARRANQUE
BTO3-1S/4	8,4	6,7	KVA 39	7,8	6,2	77,5	81,5	81	6	KVA 28	< 3,5
BTO3-2S/4	10,8	8,6	KVA 48	9,6	7,7	79,2	83,1	82,7	7,8	KVA 36	< 3,5
BTO3-1L/4	13,2	10,6	KVA 60	12	9,6	83	85,6	85,4	9,6	KVA 45	< 3,5
BTO3-2L/4	15,6	12,5	KVA 75	14,4	11,5	83,5	85,7	85,5	11,4	KVA 54	< 3,5
BTO3-3L/4	18	14,4	KVA 78	16,8	13,4	85	87	86	13,2	KVA 60	< 3,5

Tipo Type Type Typ Tipo	J (Kgm ²)			Peso/Weight Poids/Gewicht (Kg)			Vol. d'aria / Air Vol. / Vol. d'air Luftmenge / Vol. de aire (m ³ /min)		Rumore - Noise - Bruit Gerausch - Ruido dB(A)				GIUNTO A DISCHI COUPLING DISCS DISQUE DE MENOPALIER SCHEIBENKUPPLUNG JUNTA A DISCOS	
	B3/B14	B3/B9	MD35	B3/B14	B3/B9	MD35	50HZ	60HZ	50 Hz		60 Hz		SAE N°	J(kgm ²)*
									1m	7m	1m	7m		
BTO3-1S/4	0,0445	0,0444	0,0447	53	51	57	4,2	5,1	72	58	78	60	6 1/2	0,0067
BTO3-2S/4	0,0545	0,0544	0,0547	59	57	63	4,1	5					7 1/2	0,0103
BTO3-1L/4	0,0657	0,0656	0,0658	69	67	73	4	5					8	0,0171
BTO3-2L/4	0,0717	0,0716	0,0718	74	72	78	3,9	4,9					10	0,0319
BTO3-3L/4	0,0817	0,0816	0,0818	79	77	83	3,9	4,9					11 1/2	0,0481

* Il valore totale J della forma MD35 si ottiene sommando il J della forma MD35 con quello del giunto a dischi SAE prescelto.

The J value of form MD35 is obtained by summing the J of the MD35 form with the J of the chosen SAE coupling discs.

La valeur de la form MD35 est obtenue en sommant le J de la form MD35 avec celui du disque de monopulier SAE.

Der Wert J der Form MD35 wird durch die Summe von J der Form MD35 und J der ausgewählten SAE Scheibenkupplung erreicht.

El valor J de la forma MD35 se obtiene sumando el J forma MD35 con la de la junta a discos SAE seleccionada.



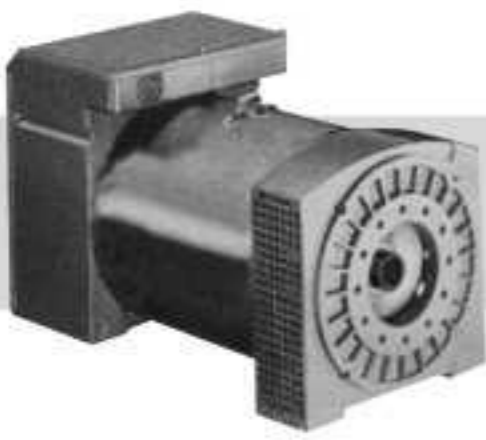

meccalte

COMPANY
WITH QUALITY SYSTEM
CERTIFIED BY DNV
ISO 9001

BTO3

MECCALTE spa - Via Roma, 20 - 36051 CREAZZO (VI) ITALIA
Tel. 0444/396111 - Fax 0444/396166 - e-mail : mecc-alte-spa@meccalte.it
web site: www.meccalte.com

3 PHASE 4 POLE IP 23

CARATTERISTICHE / CHARACTERISTICS / CARACTERISTIQUES / TECHNISCHE MERKMALE / CARACTERISTICAS

POTENZE 230/400 V A 1500 giri/min - 50 Hz		POWER 230/400 V AT 1500 RPM - 50 Hz		PUISSANCE 230/400 V A 1500 T/min - 50 Hz		LEISTUNG 230/400 V BEI 1500 UpM - 50 Hz		POTENCIAS 230/400 V A 1500 RPM - 50 Hz			
Tipo Type Type Typ Tipo	CL. H ($\Delta T=125^{\circ}\text{C}$)			CL. F ($\Delta T=105^{\circ}\text{C}$)			CL. H ($\Delta T=125^{\circ}\text{C}$)			T.H.D. %	
	TRIFASE / THREE-PHASE TRIPHASE DREIPHASIG / TRIFASICO		CAPACITA' DI SPUNTO PICKUP CAPACITY CAPACITE DE DEMARRAGE ANLEISTUNG CAPACIDAD DE ARRANQUE	TRIFASE / THREE-PHASE TRIPHASE DREIPHASIG / TRIFASICO		RENDIMENTI / EFFICIENCY RENDEMENT / WIRKUNGSGRAD RENDIMIENTOS			MONOFASE / SINGLE-PHASE MONOPHASE / EINPHASIG / MONOFASICO DELTA CONNECTION		
	KVA	KW COS φ 0,8		KVA	KW COS φ 0,8	2/4 %	3/4 %	4/4 %	KVA		CAPACITA' DI SPUNTO PICKUP CAPACITY CAPACITE DE DEMARRAGE ANLEISTUNG CAPACIDAD DE ARRANQUE
BTO3-1S/4	7	5,6	KVA 32,5	6,5	5,2	76	80	79,5	5	KVA 24	< 3,5
BTO3-2S/4	9	7,2	KVA 40	8	6,4	78	82	81,3	6,5	KVA 30	< 3,5
BTO3-1L/4	11	8,8	KVA 50	10	8	82	84,2	84	8	KVA 38	< 3,5
BTO3-2L/4	13	10,4	KVA 62,5	12	9,6	83	85	84	9,5	KVA 45	< 3,5
BTO3-3L/4	15	12	KVA 65	14	11,2	84	85,5	84,5	11	KVA 50	< 3,5

POTENZE 277/480 V A 1800 giri/min - 60 Hz		POWER 277/480 V AT 1800 RPM - 60 Hz		PUISSANCE 277/480 V A 1800 T/min - 60 Hz		LEISTUNG 277/480 V BEI 1800 UpM - 60 Hz		POTENCIAS 277/480 V A 1800 RPM - 60 Hz			
Tipo Type Type Typ Tipo	CL. H ($\Delta T=125^{\circ}\text{C}$)			CL. F ($\Delta T=105^{\circ}\text{C}$)			CL. H ($\Delta T=125^{\circ}\text{C}$)			T.H.D. %	
	TRIFASE / THREE-PHASE TRIPHASE DREIPHASIG / TRIFASICO		CAPACITA' DI SPUNTO PICKUP CAPACITY CAPACITE DE DEMARRAGE ANLEISTUNG CAPACIDAD DE ARRANQUE	TRIFASE / THREE-PHASE TRIPHASE DREIPHASIG / TRIFASICO		RENDIMENTI / EFFICIENCY RENDEMENT / WIRKUNGSGRAD RENDIMIENTOS			MONOFASE / SINGLE-PHASE MONOPHASE / EINPHASIG / MONOFASICO DELTA CONNECTION		
	KVA	KW COS φ 0,8		KVA	KW COS φ 0,8	2/4 %	3/4 %	4/4 %	KVA		CAPACITA' DI SPUNTO PICKUP CAPACITY CAPACITE DE DEMARRAGE ANLEISTUNG CAPACIDAD DE ARRANQUE
BTO3-1S/4	8,4	6,7	KVA 39	7,8	6,2	77,5	81,5	81	6	KVA 28	< 3,5
BTO3-2S/4	10,8	8,6	KVA 48	9,6	7,7	79,2	83,1	82,7	7,8	KVA 36	< 3,5
BTO3-1L/4	13,2	10,6	KVA 60	12	9,6	83	85,6	85,4	9,6	KVA 45	< 3,5
BTO3-2L/4	15,6	12,5	KVA 75	14,4	11,5	83,5	85,7	85,5	11,4	KVA 54	< 3,5
BTO3-3L/4	18	14,4	KVA 78	16,8	13,4	85	87	86	13,2	KVA 60	< 3,5

Tipo Type Type Typ Tipo	J (Kgm ²)			Peso/Weight Poids/Gewicht (Kg)			Vol. d'aria / Air Vol. / Vol. d'air Luftmenge / Vol. de aire (m ³ /min)		Rumore - Noise - Bruit Gerausch - Ruido dB(A)				GIUNTO A DISCHI COUPLING DISCS DISQUE DE MENOPALIER SCHEIBENKUPPLUNG JUNTA A DISCOS	
	B3/B14	B3/B9	MD35	B3/B14	B3/B9	MD35	50HZ	60HZ	50 Hz		60 Hz		SAE N°	J(kgm ²)*
									1m	7m	1m	7m		
BTO3-1S/4	0,0445	0,0444	0,0447	53	51	57	4,2	5,1	72	58	78	60	6 1/2	0,0067
BTO3-2S/4	0,0545	0,0544	0,0547	59	57	63	4,1	5					7 1/2	0,0103
BTO3-1L/4	0,0657	0,0656	0,0658	69	67	73	4	5					8	0,0171
BTO3-2L/4	0,0717	0,0716	0,0718	74	72	78	3,9	4,9					10	0,0319
BTO3-3L/4	0,0817	0,0816	0,0818	79	77	83	3,9	4,9					11 1/2	0,0481

* Il valore totale J della forma MD35 si ottiene sommando il J della forma MD35 con quello del giunto a dischi SAE prescelto.

The J value of form MD35 is obtained by summing the J of the MD35 form with the J of the chosen SAE coupling discs.

La valeur de la form MD35 est obtenue en sommant le J de la form MD35 avec celui du disque de monopulier SAE.

Der Wert J der Form MD35 wird durch die Summe von J der Form MD35 und J der ausgewählten SAE Scheibenkupplung erreicht.

El valor J de la forma MD35 se obtiene sumando el J forma MD35 con la de la junta a discos SAE seleccionada.



Electrical Characteristics										
Frequency	Hz	50				60				
Voltage (series star)	V	380	400	415	440	415	440	460	480	
Rated power class H	kVA	60	60	60	50	60	68	72	72	
	kW	48	48	48	40	48	54,4	57,6	57,6	
Rated power class F	kVA	57	57	57	45	55	65	69	69	
	kW	45,6	45,6	45,6	36	44	52	55,2	55,2	
Regulation with SR7/2		±1,5 % with any power factor and speed variations between -5% +30%								
Insulation class		H								
Execution		Brushless								
Stator winding		12 ends								
Rotor		with damping cage								
Efficiencies class H	4/4	%	90,2	90,3	90	89,5	92,2	92,7	92,8	92,9
(see graph. for details)	3/4	%	90,5	90,8	90,7	90,4	92,7	92,9	93,1	93,3
	2/4	%	89,4	89,5	89,5	89,5	90,8	90,9	91	91,1
	1/4	%	86,2	86	85,8	85,5	87	87	87	87
Reactances (f. l.cl. F)	Xd	%	299,2	270	250,8	186,0	301,0	303,5	294,0	270
	Xd'	%	14,18	12,8	11,89	8,82	14,27	14,39	13,94	12,8
	Xd''	%	7,53	6,8	6,32	4,68	7,58	7,64	7,40	6,8
	Xq	%	117,5	106	98,5	73,0	118,2	119,1	115,4	106
	Xq'	%	117,5	106	98,5	73,0	118,2	119,1	115,4	106
	Xq''	%	36,6	33	30,7	22,7	39,6	34,9	33,0	33
	X ₂	%	24,71	22,3	20,72	15,36	24,86	25,06	24,28	22,3
	X ₀	%	3,32	3	2,79	2,07	3,34	3,37	3,27	3
Short Circuit Ratio	Kcc		0,48	0,60	0,70	1,30	0,35	0,40	0,48	0,60
Time Constants	Td'	sec.	0,062							
	Td''	sec.	0,014							
	Tdo'	sec.	1,20							
	Tα	sec.	0,028							
Short Circuit Current Capacity		%	>300				>350			
Excitation at no load	Amp.		0,5	0,6	0,7	1	0,3	0,4	0,45	0,6
Excitation at full load	Amp.		1,9	1,9	2,4	2,8	1,6	1,7	1,8	2
Overload (long-term)		%	1 hour in a 6 hours period 110% rated load							
Overload per 20 sec.		%	300							
Stator Winding Resistance (20°C)	Ω		0,041							
Rotor Winding Resistance (20°C)	Ω		2,861							
Exciter Resistance (20 °C)	Ω		Rotor : 0,442				Stator : 11,35			
Heat dissipation at f.l.cl.H	W		5215	5156	5333	4693	4061	4284	4469	4402
Telephone Interference			FHT < 2%				TIF < 45			
Radio interference			EN50081-1, EN50082-1, VDE0875K. For others standards apply to factory							
Waveform Distors.(THD) at f. load	LL/LN %		3,8 / 3,6							
Waveform Distors.(THD) at no load	LL/LN %		3 / 2,9							
Mechanical characteristics										
Protection			IP 21 (other protection on request)							
DE bearing			6312-2RS							
NDE bearing			6309-2RS							
Weight of wound stator assembly	kg		95							
Weight of wound rotor assembly	kg		64							
Weight of complete generator	kg		282							
Maximun overspeed	rpm		2250							
Unbalanced magnetic pull at f.l.cl.F	kN/mm		4,7							
Cooling air requirement	m ³ /min		11,8				14,5			
Inertia Constant (H)	sec.		0,104				0,125			
Noise level at 1m/7m	dB(A)		75 / 60				79 / 64			

This document is a propriety of Mecc Alte S.p.a..All rights reserved.

50 Hz

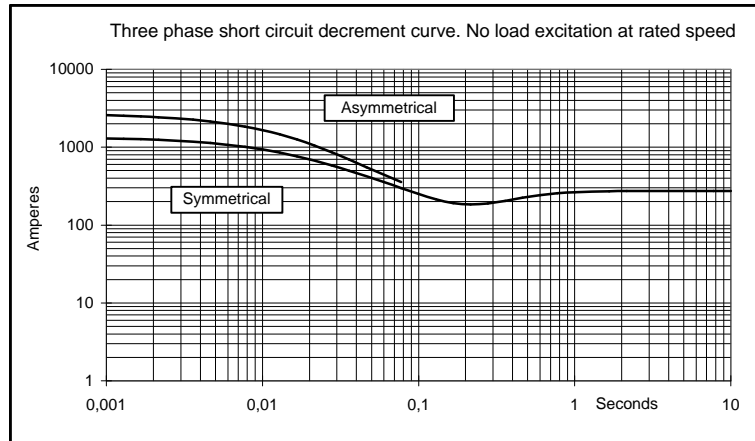
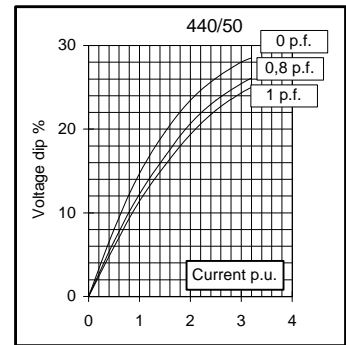
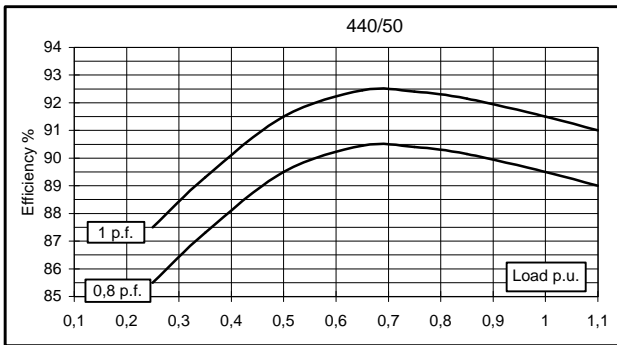
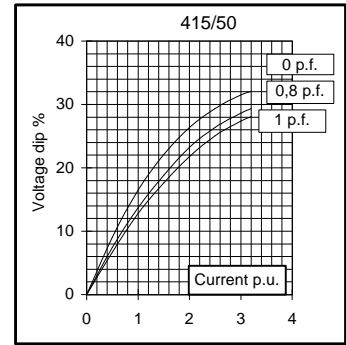
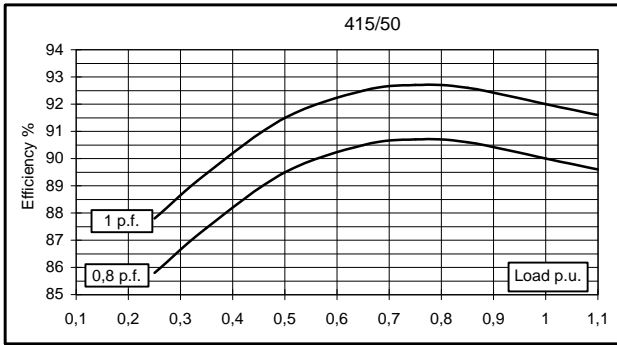
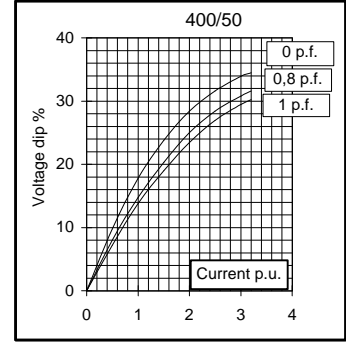
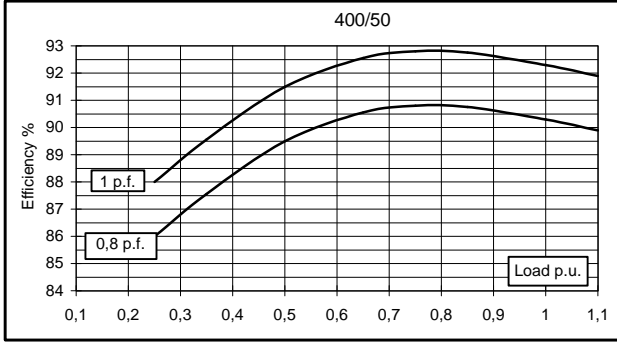
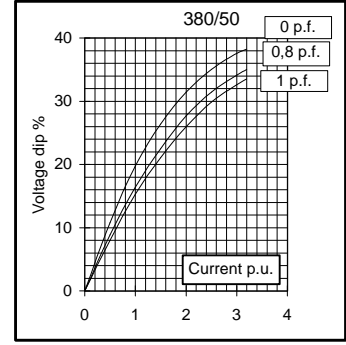
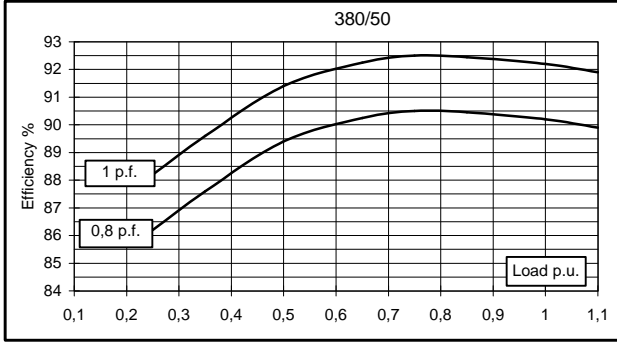

This document is a propriety of Mecc Alte S.p.a.. All rights reserved.

60 Hz

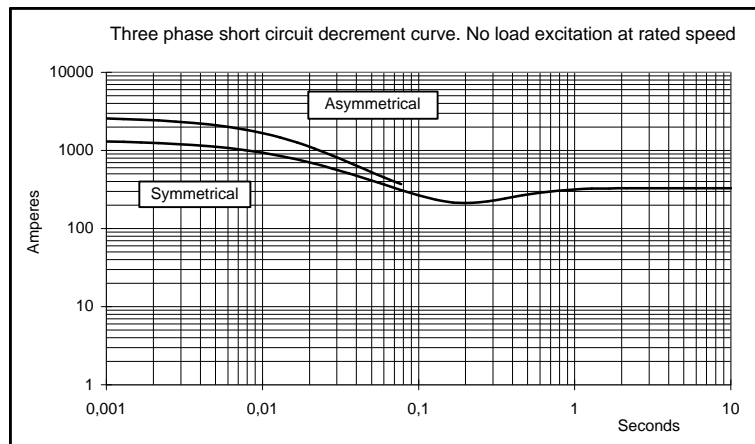
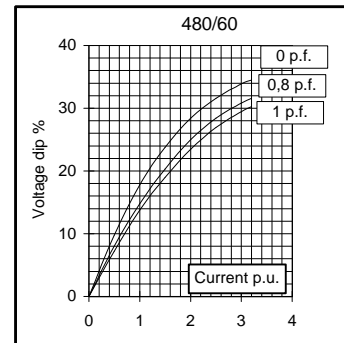
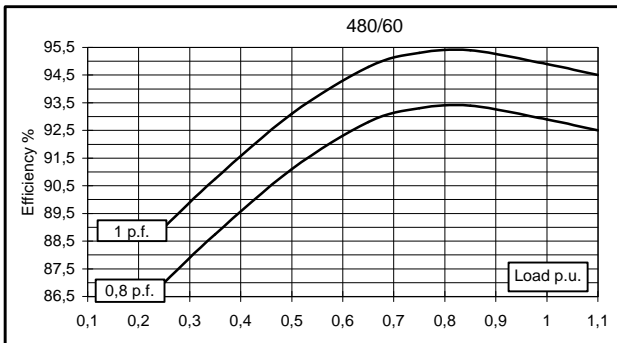
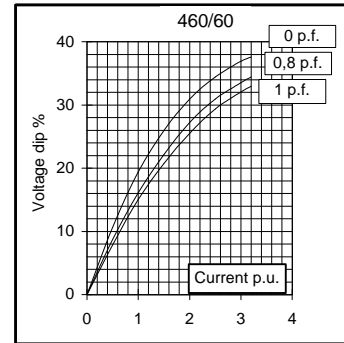
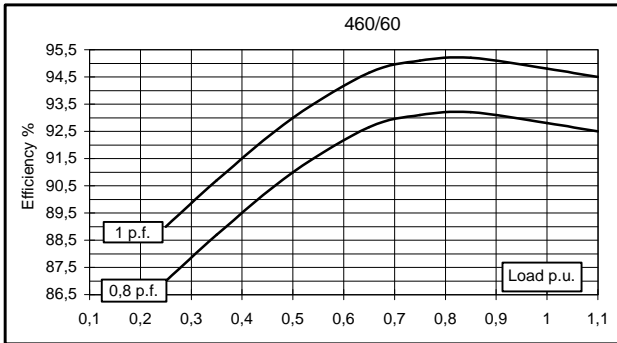
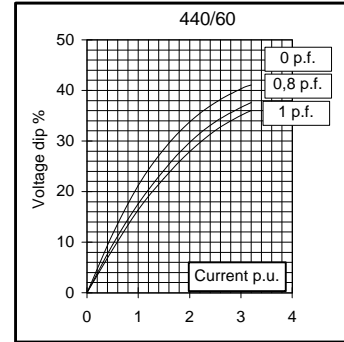
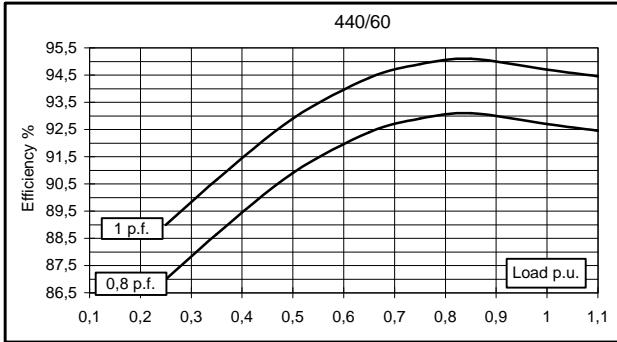
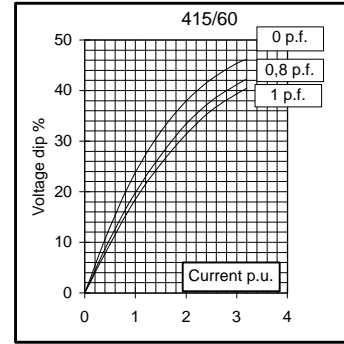
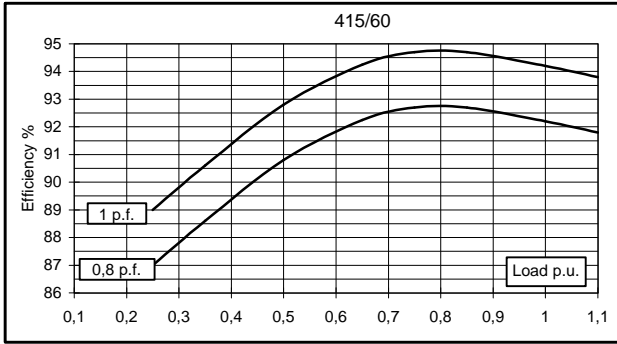

This document is a propriety of Mecc Alte S.p.a.. All rights reserved.

TWO BEARING MOMENTS OF INERTIA

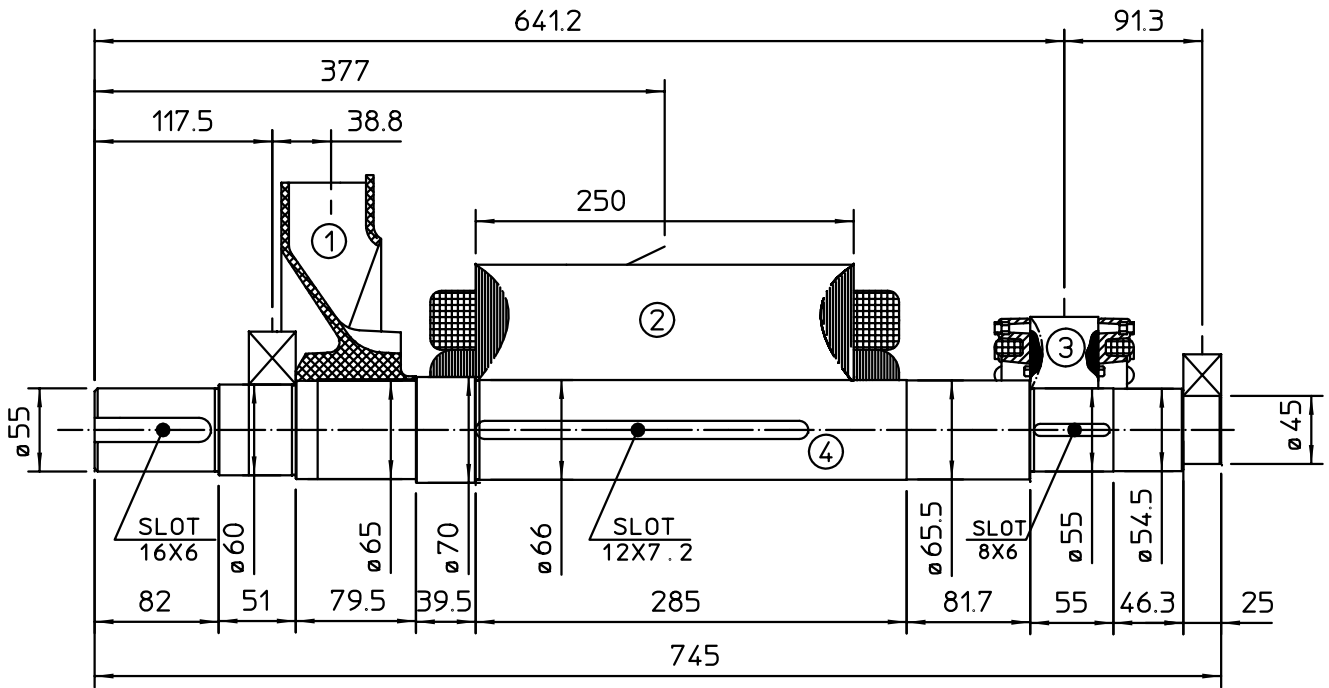

COMPONENT	WEIGHT kg	J kgm ²
1 FAN	2.3	0.0224
2 MAIN ROTOR	64.5	0.4579
3 EX. ROTOR	7	0.016
4 SHAFT	17.5	0.008
TOTAL	91.3	0.5043

DIMENSIONS **FAMCO**
هایپر صنعت

FAMCO
هایپر صنعت

TWO BEARING

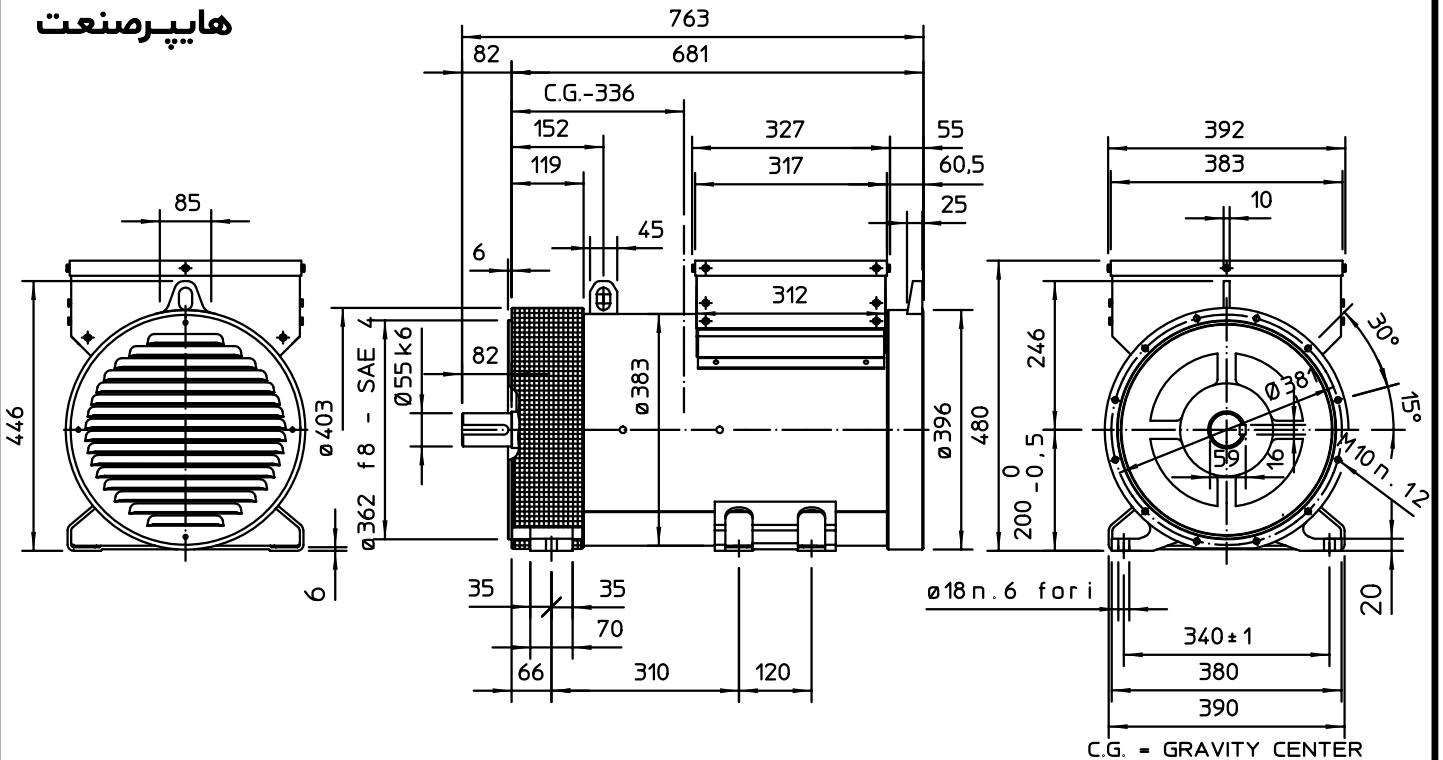

C.G. = GRAVITY CENTER

SINGLE BEARING MOMENTS OF INERTIA

FAMCO
هایپر صنعت

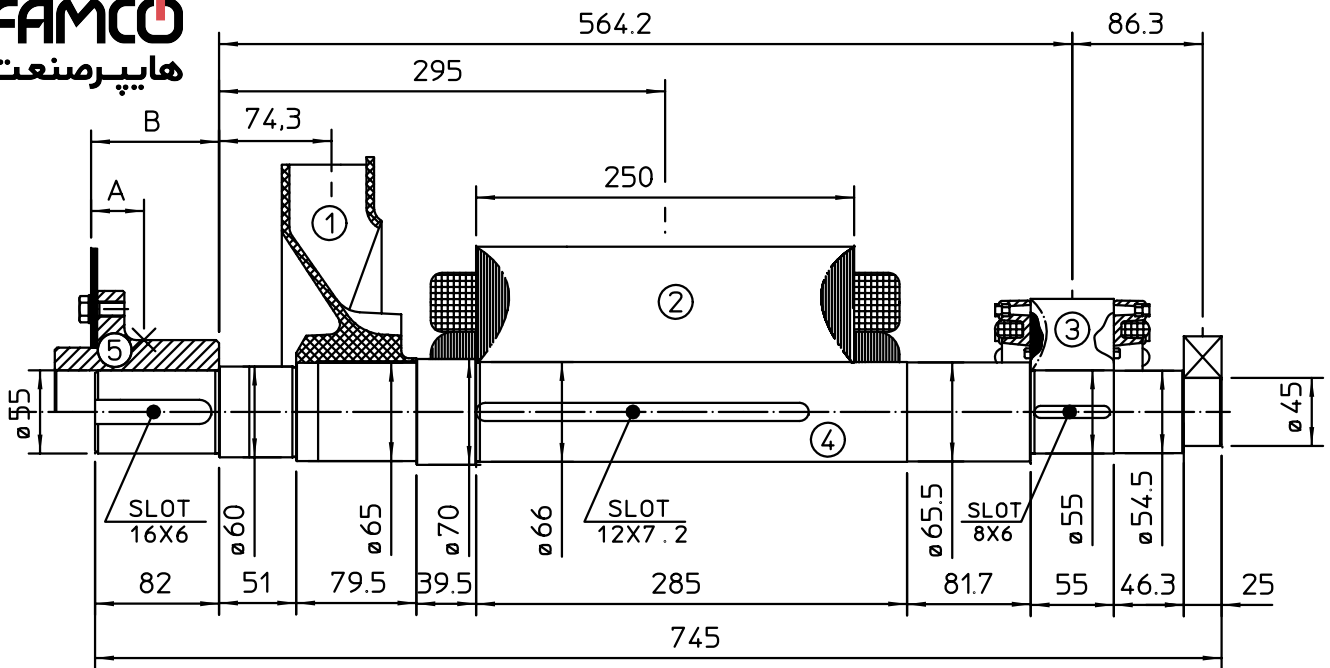

COMPONENT	WEIGHT kg	J kgm ²
1 FAN	2,3	0,0224
2 MAIN ROTOR	64,5	0,4579
3 EX. ROTOR	7	0,016
4 SHAFT	17,5	0,008
TOTAL	91,3	0,5043

SAE No	SHAFTS COUPLING FLEX PLATE			
	A	B	WEIGHT kg	J kgm ²
6,5	26,1	75,2	4,2	0,0225
7,5	25,7	75,2	4,4	0,0256
8	38,25	106,9	7,2	0,0314
10	32,7	98,7	8,7	0,0485
11,5	24	84,5	8,3	0,0372

FAMCO
هایپر صنعت

SINGLE BEARING DIMENSIONS

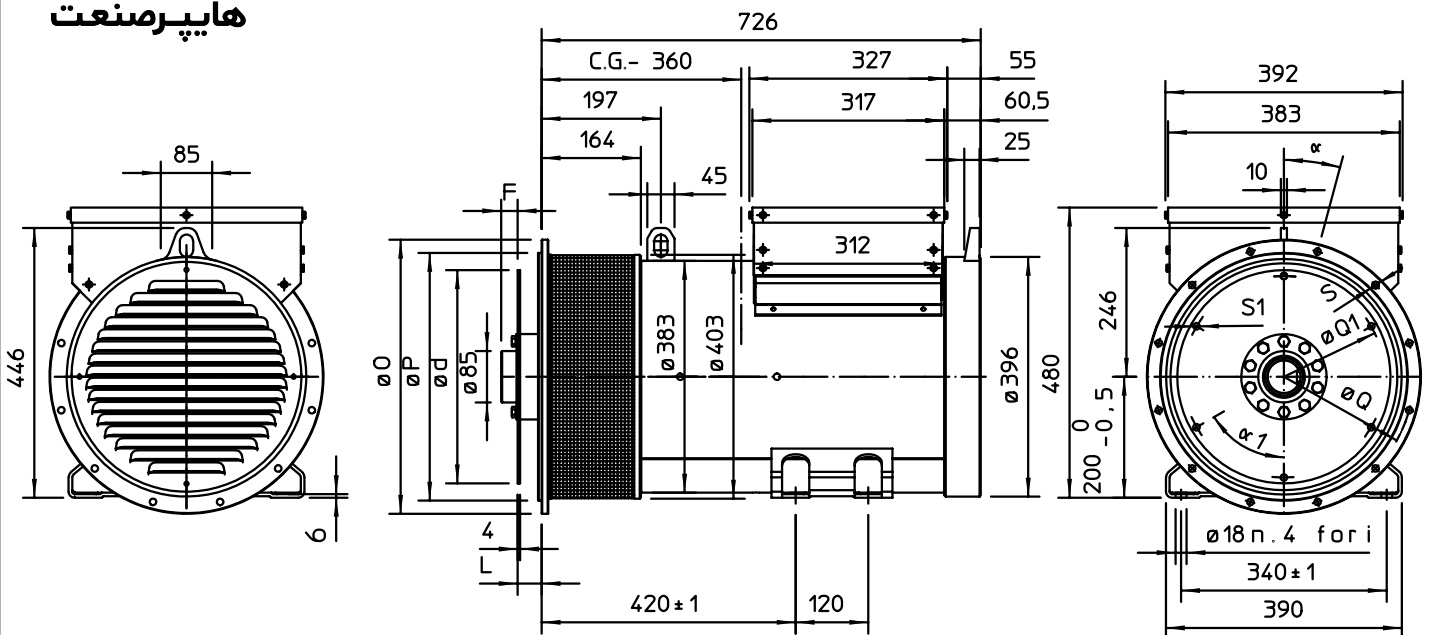

SAE No	DISC COUPLING						
	L	d	Q1	No holes	S1	a1	F
6,5	30,2	215,9	200	6	9	60°	7
7,5	30,2	241,3	222,25	8	9	45°	7
8	62	263,52	244,47	6	11	60°	2
10	53,8	314,32	295,27	8	11	45°	10
11,5	39,6	352,42	333,37	8	11	45°	24

SAE No	FLANGE					
	O	P	Q	No holes	S	a
5	356	314,3	333,4	8	11	22°30'
4	403	362	381	12	11	15°
3	451	409,6	428,6	12	11	15°
2	489	447,7	466,7	12	11	15°
1	552	511,2	530,2	12	11	15°

C.G. = GRAVITY CENTER

Electrical Characteristics										
Frequency	Hz	50				60				
Voltage (series star)	V	380	400	415	440	415	440	460	480	
Rated power class H	kVA	400	400	400	370	420	450	480	480	
	kW	320	320	320	296	336	360	384	384	
Rated power class F	kVA	370	370	370	342	383	410	440	440	
	kW	296	296	296	274	306	328	352	352	
Regulation with UVR6		±1% with any power factor and speed variations between -5% +30%								
Insulation class		H								
Execution		Brushless								
Stator winding		12 ends								
Rotor		with damping cage								
Efficiencies class H	4/4	%	93,4	93,5	93,2	93	94,3	94,8	94,9	95
(see graph. for details)	3/4	%	93,5	93,8	93,7	93,4	94,6	94,8	94,9	95,2
	2/4	%	92,8	92,9	92,9	92,7	94,1	94,2	94,3	94,4
	1/4	%	89,2	89	88,8	88,7	90	90,1	90,1	90
Reactances (f. l.cl. F)	Xd	%	319,3	288,2	267,7	220,3	337,4	321,5	313,8	288
	Xd'	%	32,4	29,2	27,1	22,3	34,2	32,6	31,8	29,2
	Xd''	%	21,1	19,0	17,7	14,5	22,2	21,2	20,7	19,0
	Xq	%	144,9	130,8	121,5	100,0	153,1	145,9	142,4	130,8
	Xq'	%	144,9	130,8	121,5	100,0	153,1	145,9	142,4	130,8
	Xq''	%	39,2	35,4	32,9	27,1	41,4	39,5	38,5	35,4
	X ₂	%	30,1	27,2	25,3	20,8	31,8	30,3	29,6	27,2
	X ₀	%	4,18	3,77	3,50	2,88	4,41	4,21	4,10	3,77
Short Circuit Ratio	Kcc		0,30	0,36	0,55	0,90	0,24	0,27	0,30	0,36
Time Constants	Td'	sec.	0,11							
	Td''	sec.	0,014							
	Tdo'	sec.	2,50							
	Tα	sec.	0,013							
Short Circuit Current Capacity		%	>300				>350			
Excitation at no load	Amp.		0,7	0,8	0,9	1,1	0,5	0,6	0,7	0,8
Excitation at full load	Amp.		3,4	3,6	3,7	3,8	3,1	3,3	3,4	3,5
Overload (long-term)		%	1 hour in a 6 hours period 110% rated load							
Overload per 20 sec.		%	300							
Stator Winding Resistance (20°C)	Ω		0,0048							
Rotor Winding Resistance (20°C)	Ω		4,488							
Exciter Resistance (20 °C)	Ω		Rotor : 0,317				Stator : 8,85			
Heat dissipation at f.l.cl.H	W		22612	22246	23348	22280	20310	19747	20636	20211
Telephone Interference			FHT < 2%				TIF < 40			
Radio interference			EN50081-1, EN50082-1, VDE0875K. For others standards apply to factory							
Waveform Distors.(THD) at f. load	LL/LN %		2,6 / 2,6							
Waveform Distors.(THD) at no load	LL/LN %		2,9 / 2,9							
Mechanical characteristics										
Protection			IP 21 (other protection on request)							
DE bearing			6322							
NDE bearing			6318.2RS							
Weight of wound stator assembly	kg		327							
Weight of wound rotor assembly	kg		211							
Weight of complete generator	kg		1040							
Maximun overspeed	rpm		2250							
Unbalanced magnetic pull at f.l.cl.F	kN/mm		5							
Cooling air requirement	m ³ /min		54				64,8			
Inertia Constant (H)	sec.		0,176				0,212			
Noise level at 1m/7m	dB(A)		94 / 82				98 / 88			

All technical data are to be considered as a reference and they can be modified without any notice.

This document is a propriety of Mecc Alte S.p.A.. All rights reserved.

50 Hz

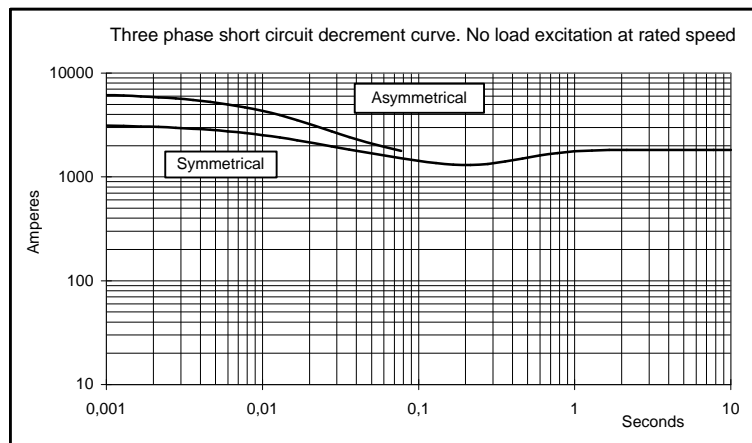
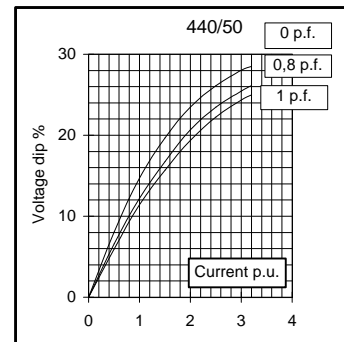
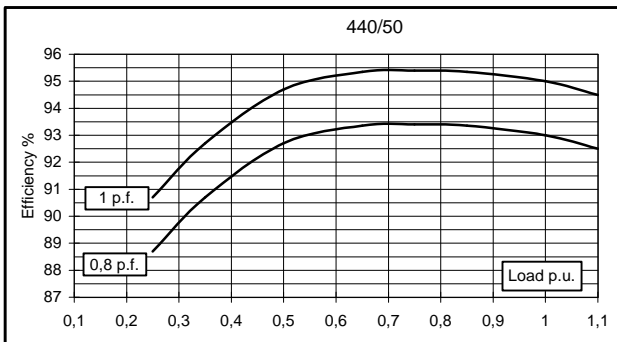
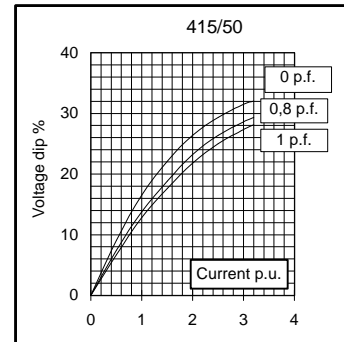
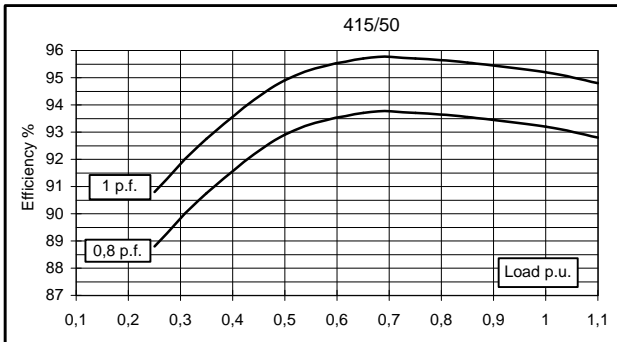
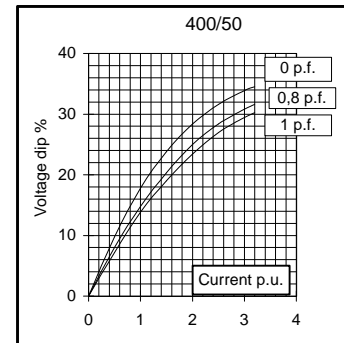
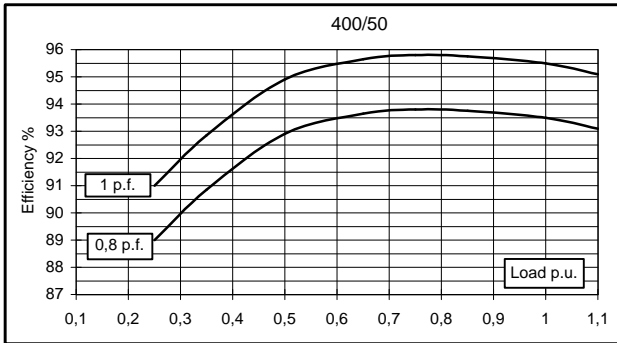
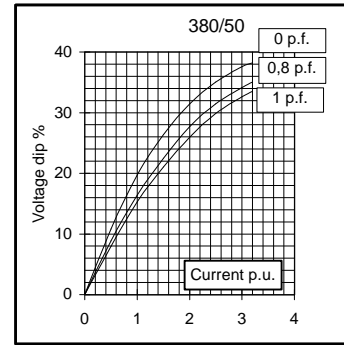
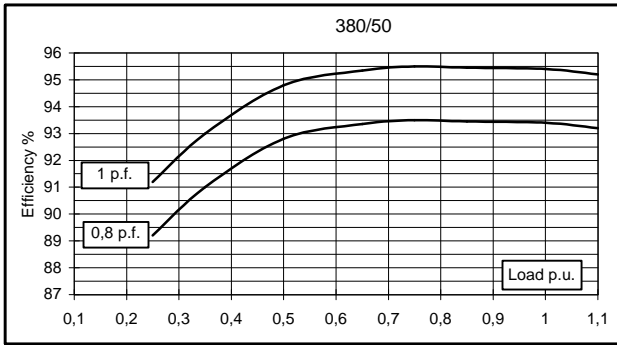

This document is a propriety of Mecc Alte S.p.a.. All rights reserved.

60 Hz

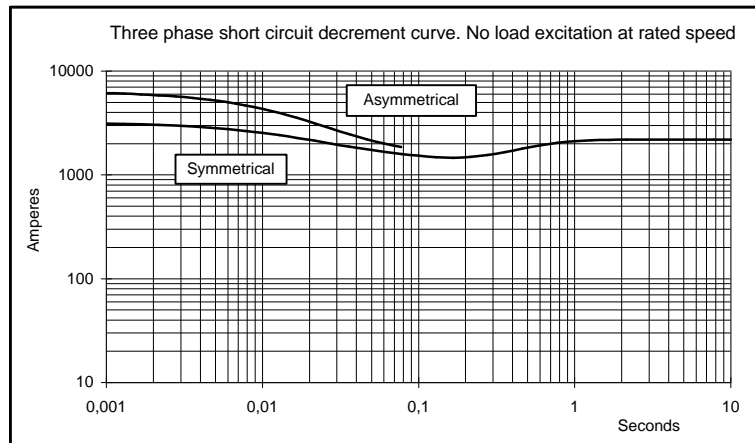
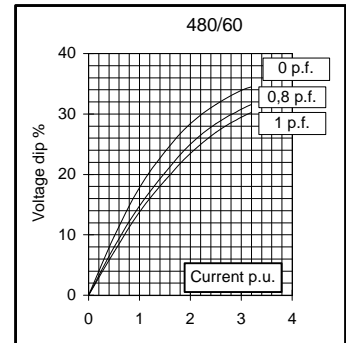
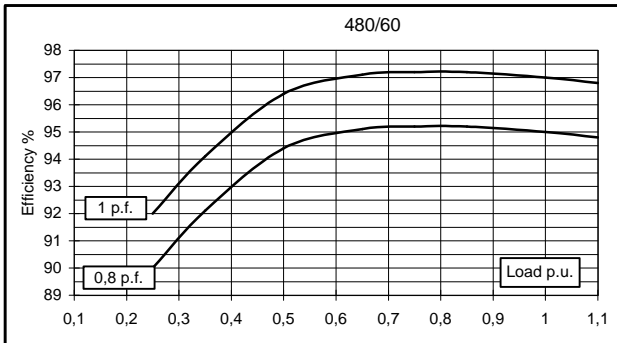
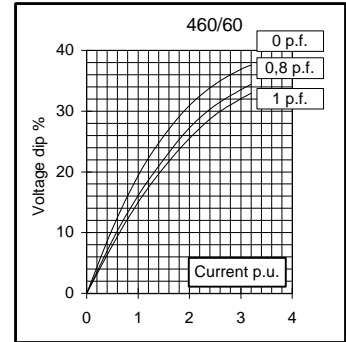
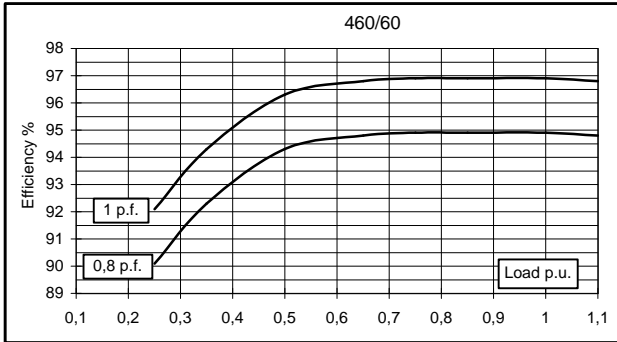
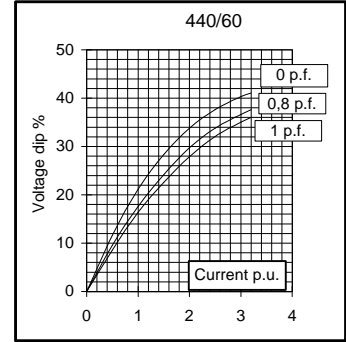
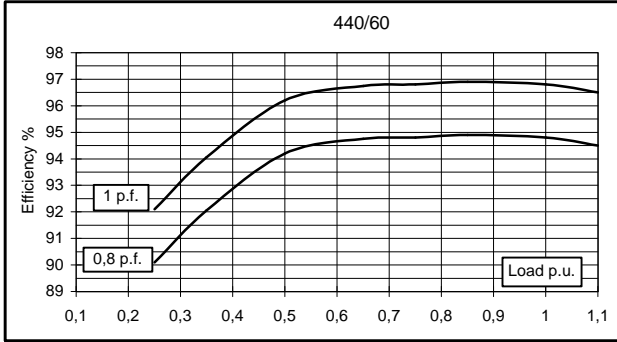
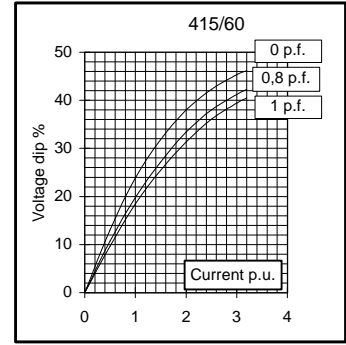
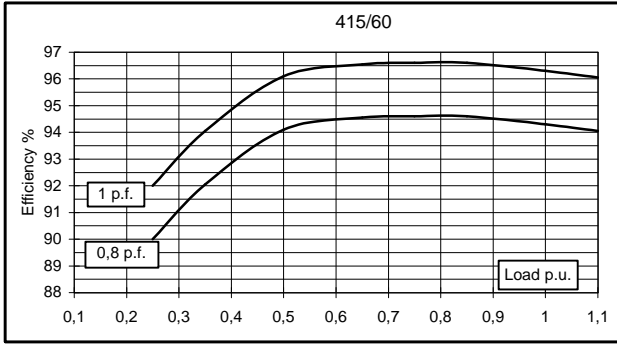

This document is a propriety of Mecc Alte S.p.a.. All rights reserved.

TWO BEARING MOMENTS OF INERTIA

FAMCO
هایپرمنت

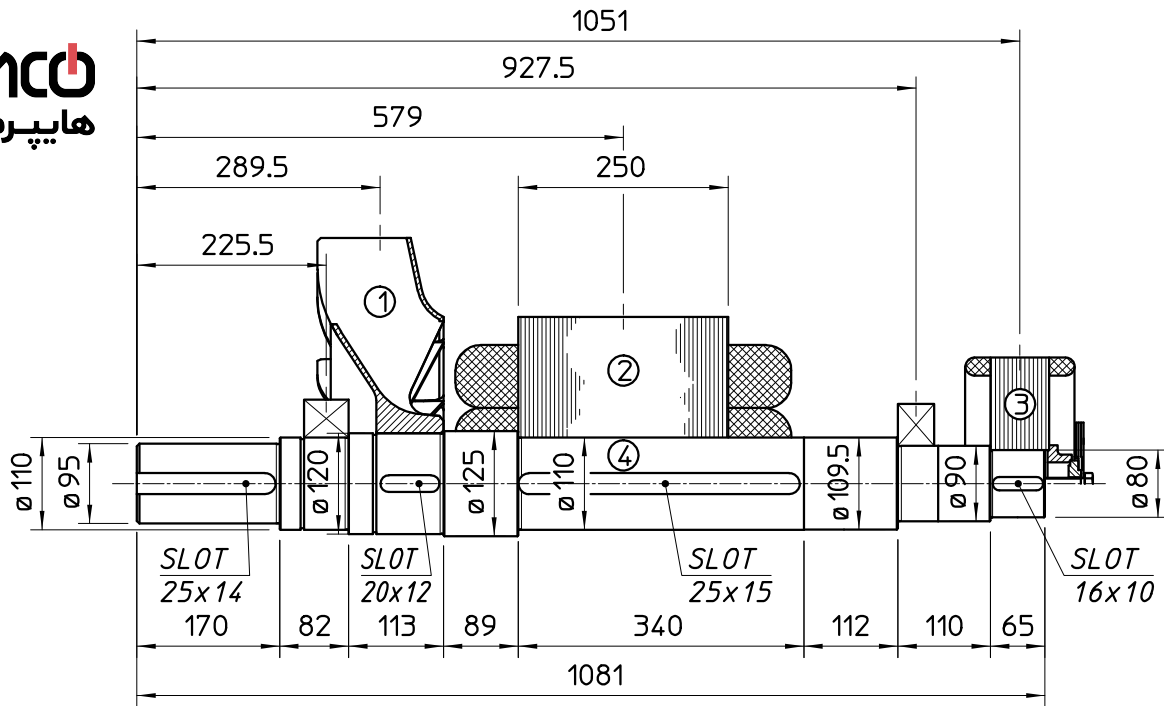

COMPONENT	WEIGHT kg	J kgm ²
1 FAN	16	0.550
2 MAIN ROTOR	211	4.498
3 EX. ROTOR	35	0.562
4 SHAFT	75	0.109
TOTAL	337	5.719

FAMCO
هایپرمنت

TWO BEARING DIMENSIONS

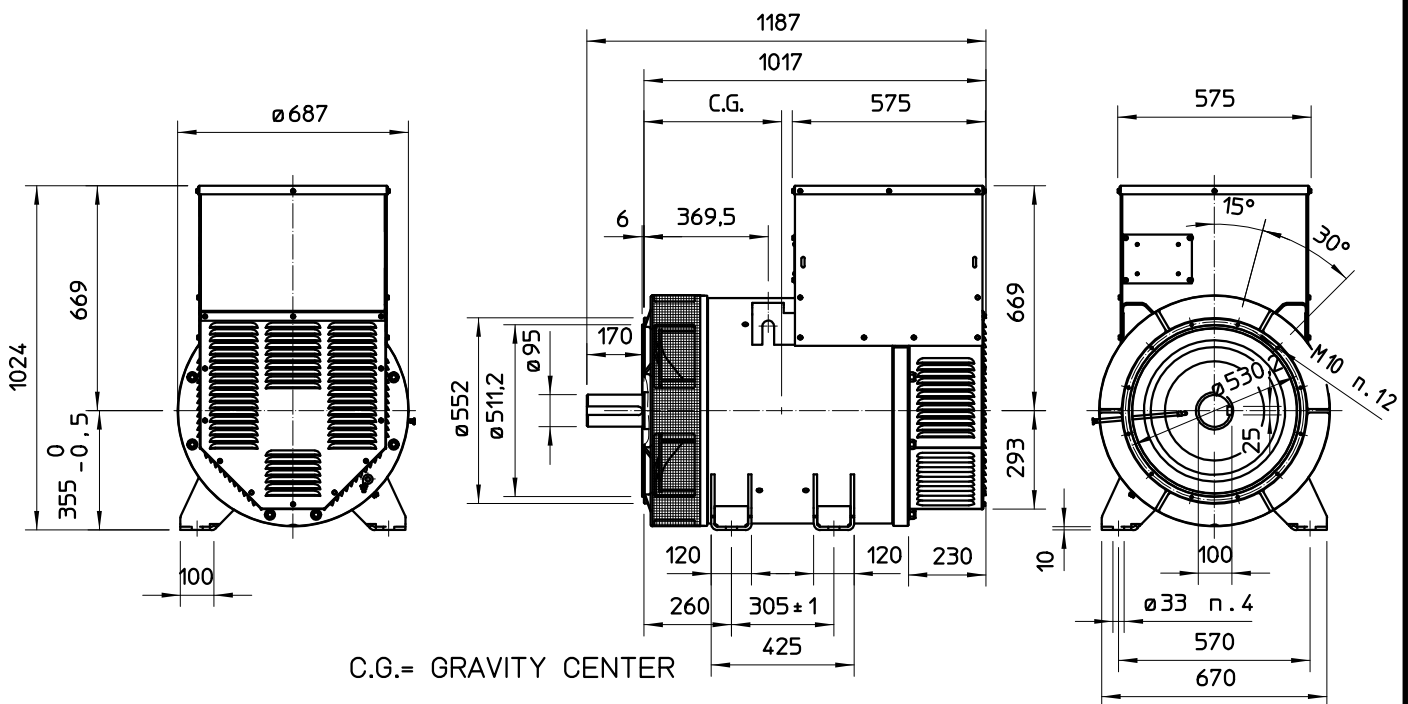

SINGLE BEARING MOMENTS OF INERTIA

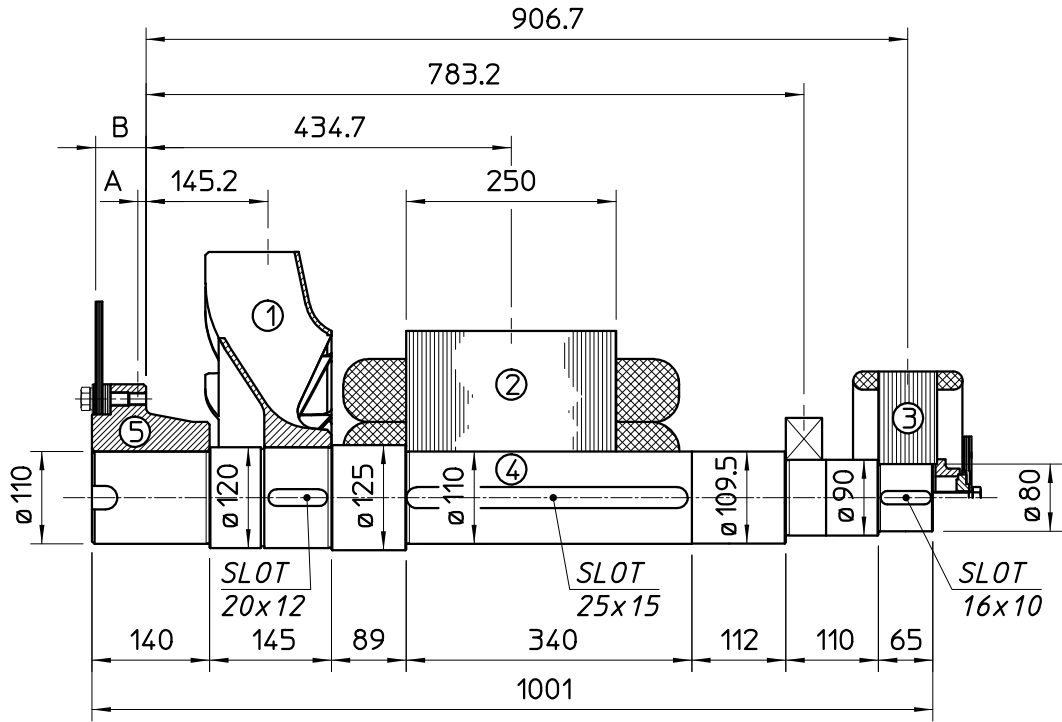

COMPONENT	WEIGHT kg	J kgm ²
1 FAN	16	0.550
2 MAIN ROTOR	211	4.498
3 EX. ROTOR	35	0.562
4 SHAFT	72.7	0.106
TOTAL	334.7	5.716

SAE No	SHAFTS COUPLING FLEX PLATE			
	A	B	WEIGHT kg	J kgm ²
14	9,6	60	41,4	0,511
18	6,6	50	45,1	0,858



SINGLE BEARING DIMENSIONS

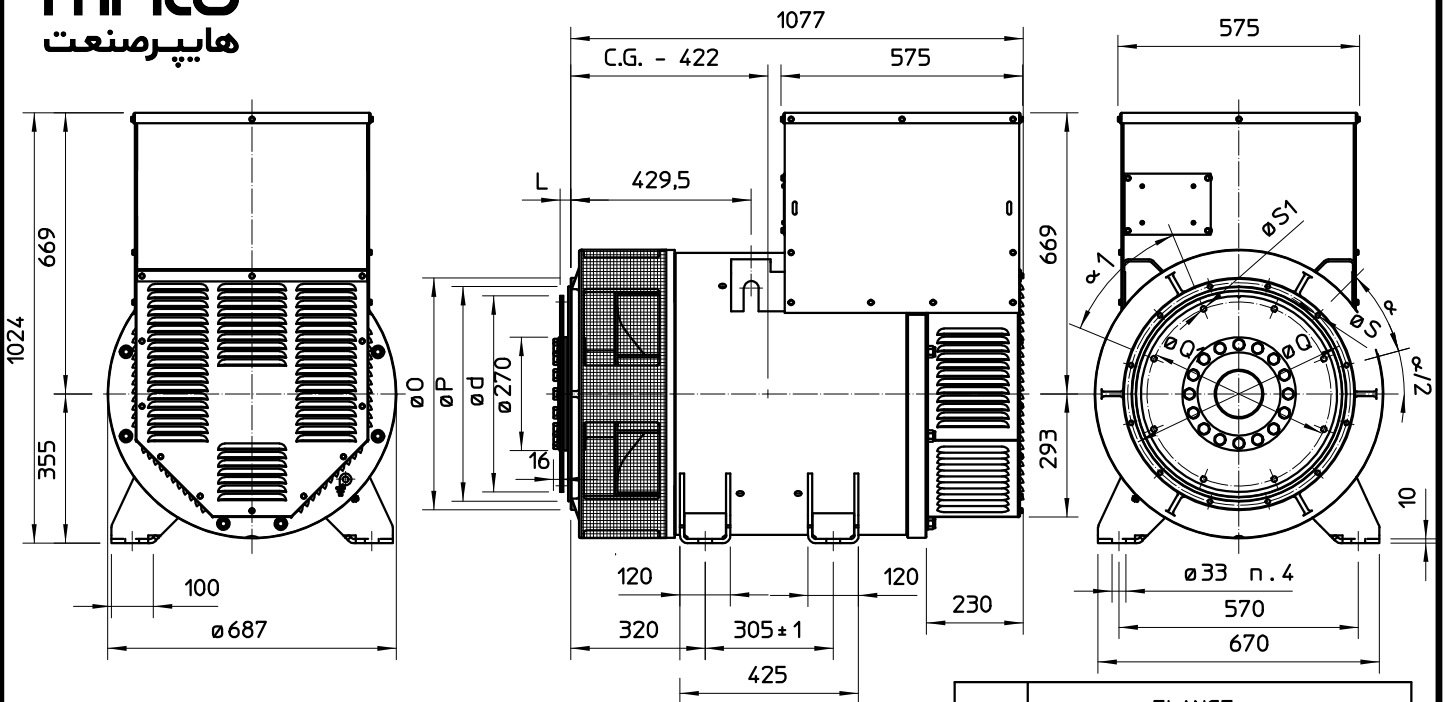

SAE N.	DISC COUPLING					
	L	d	Q1	N. FORI	S1	α1
14	25,4	466,72	438,15	8	14	45°
18	15,7	571,5	542,92	6	17	60°

SAE N.	FLANGE					
	O	P	Q	N. FORI	S	α
1	552	511,2	530,2	12	11	15°
1/2	648	584,2	619,1	12	14	15°
0	711	647,7	679,5	16	14	11°15'
00	883	787,4	850,9	16	14	11°15'

C.G.= GRAVITY CENTER

Electrical Characteristics										
Frequency	Hz	50				60				
Voltage (series star)	V	380	400	415	440	415	440	460	480	
Rated power class H	kVA	35	35	35	28	41	42	42	42	
	kW	28	28	28	22,4	32,8	34	33,6	33,6	
Rated power class F	kVA	33	33	33	26	39	40	40	40	
	kW	26,4	26,4	26,4	20,8	31,2	32	32	32	
Regulation with	DSR	±1 % with any power factor and speed variations between -5% +30%								
Insulation class		H								
Execution		Brushless								
Stator winding		12 ends								
Rotor		with damping cage								
Efficiencies class H	4/4	%	88,1	88,2	87,9	87,7	89,1	89,6	89,7	89,8
(see graph. for details)	3/4	%	88,3	88,6	88,5	88,2	89,6	90	90	90,2
	2/4	%	86,7	86,8	86,8	86,8	88,5	88,8	88,9	89
	1/4	%	81,7	81,5	81,3	81,2	85,1	85,3	85,4	85,5
Reactances (f. l.c.l. F)	Xd	%	277,0	250	232,3	165,3	326,5	297,5	272,2	250
	Xd'	%	16,62	15	13,94	9,92	19,59	17,85	16,33	15
	Xd''	%	11,75	10,6	9,85	7,01	13,84	12,61	11,54	10,6
	Xq	%	100,8	91	84,5	60,2	118,8	108,3	99,1	91
	Xq'	%	100,8	91	84,5	60,2	118,8	108,3	99,1	91
	Xq''	%	34,3	31	28,8	20,5	40,5	36,9	33,8	31
	X ₂	%	24,38	22	20,44	14,55	28,73	26,18	23,95	22
	X ₀	%	3,10	2,8	2,60	1,85	3,66	3,33	3,05	2,8
Short Circuit Ratio	Kcc		0,60	0,70	0,86	1,38	0,40	0,50	0,60	0,70
Time Constants	Td'	sec.	0,058							
	Td''	sec.	0,012							
	Tdo'	sec.	1,35							
	Tα	sec.	0,025							
Short Circuit Current Capacity		%	>300				>350			
Excitation at no load	Amp.		0,47	0,64	0,73	1,1	0,3	0,4	0,46	0,6
Excitation at full load	Amp.		2,1	2,2	2	2,5	1,9	1,7	1,6	1,7
Overload (long-term)	%	1 hour in a 6 hours period 110% rated load								
Overload per 20 sec.	%	300								
Stator Winding Resistance (20°C)	Ω	0,097								
Rotor Winding Resistance (20°C)	Ω	2,01								
Exciter Resistance (20 °C)	Ω	Rotor : 0,417				Stator : 10,6				
Heat dissipation at f.l.c.l.H	W	3782	3746	3854	3142	4013	3900	3858	3816	
Telephone Interference		THF < 2%				TIF > 45				
Radio interference		EN61000-6-3, EN61000-6-1. For others standards apply to factory								
Waveform Distors.(THD) at f. load	LL/LN %	4 / 3,9								
Waveform Distors.(THD) at no load	LL/LN %	3,5 / 3,4								
Mechanical characteristics										
Protection		IP 21 (other protection on request)								
DE bearing		6312-2RS								
NDE bearing		6309-2RS								
Weight of wound stator assembly	kg	56								
Weight of wound rotor assembly	kg	39,5								
Weight of complete generator	kg	199								
Maximum overspeed	rpm	2250								
Unbalanced magnetic pull at f.l.c.l.F	kN/mm	4,5								
Cooling air requirement	m ³ /min	11,8				14,5				
Inertia Constant (H)	sec.	0,113				0,136				
Noise level at 1m/7m	dB(A)	75 / 60				79 / 64				

All technical data are to be considered as a reference and they can be modified without notice

This document is a propriety of Mecc Alte S.p.a..All rights reserved.

50 Hz

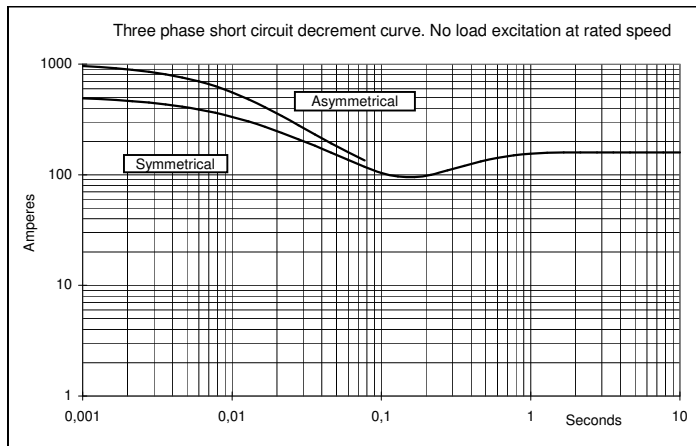
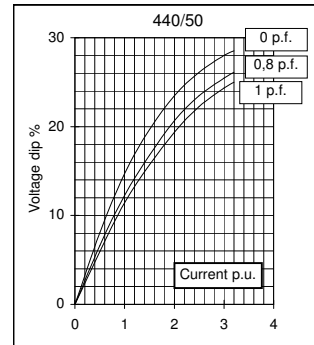
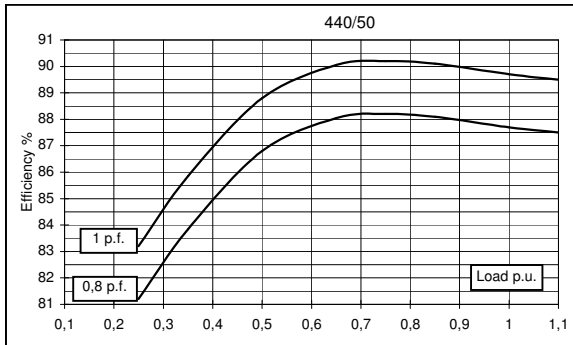
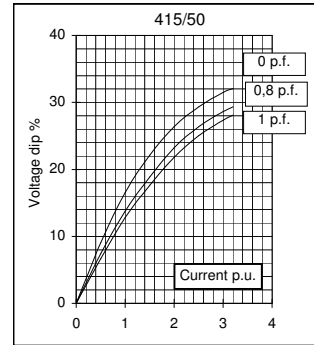
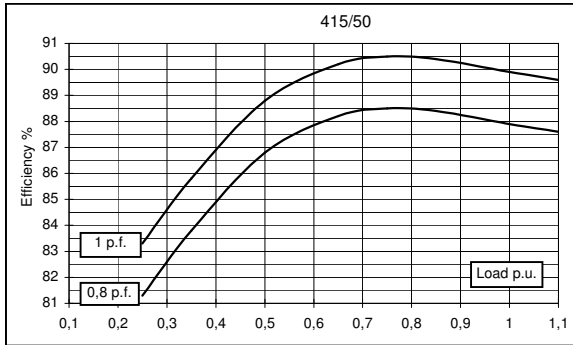
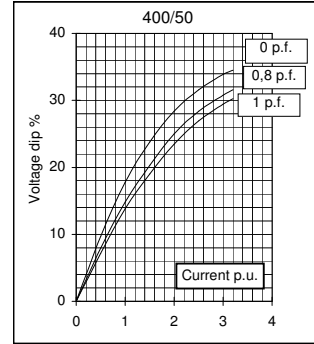
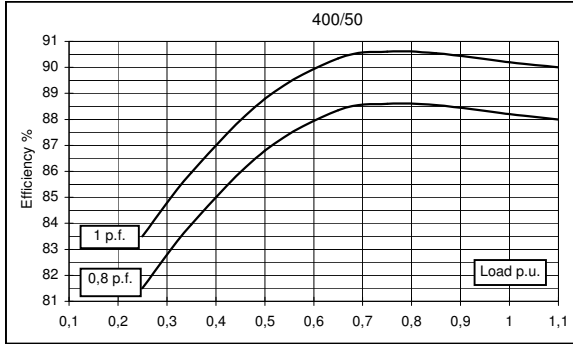
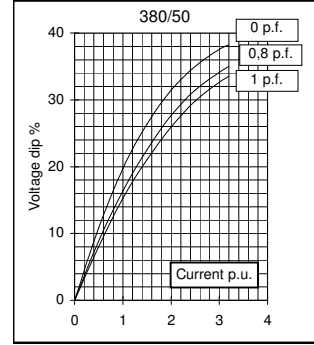
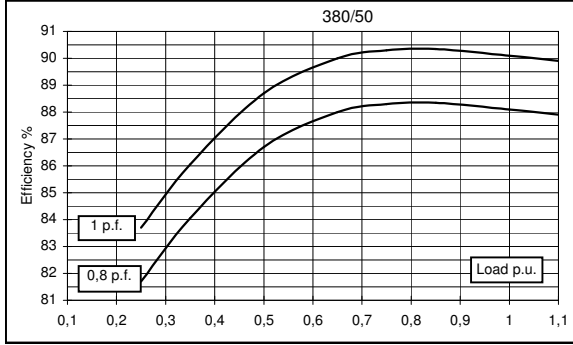

This document is a propriety of Mecc Alte S.p.a.. All rights reserved.

60 Hz

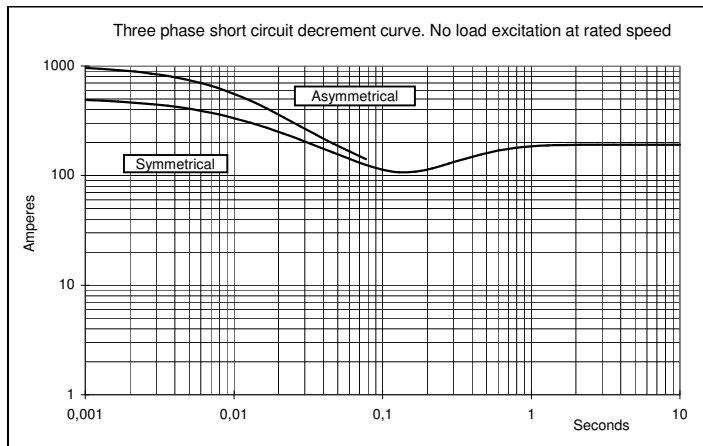
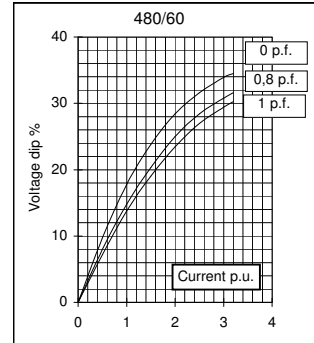
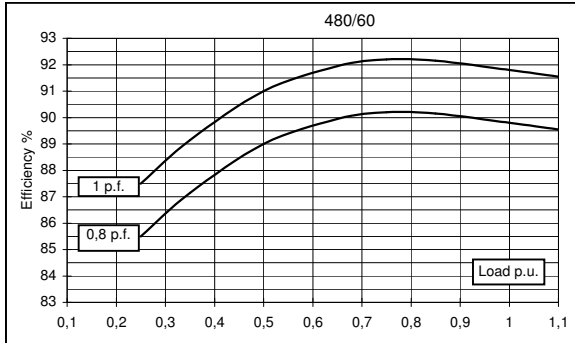
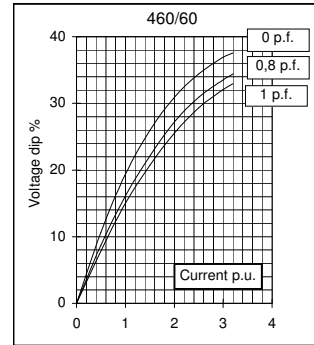
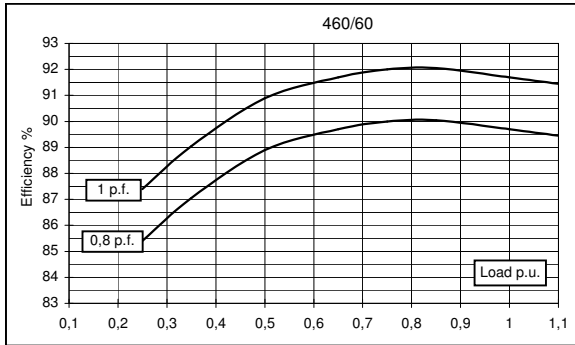
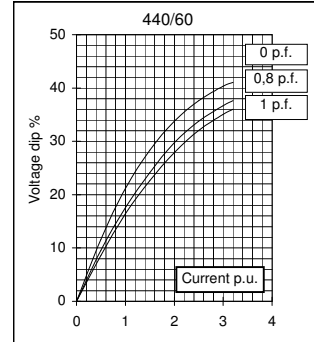
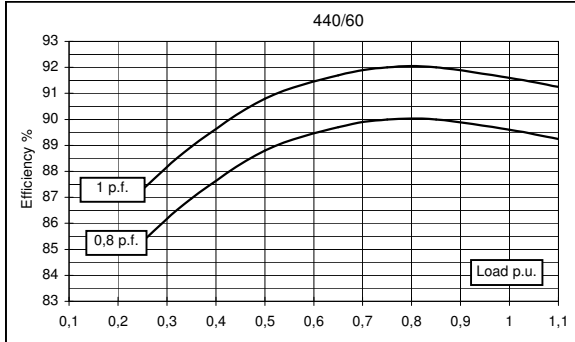
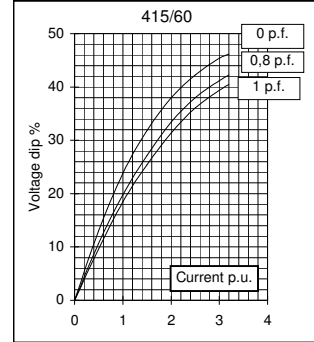
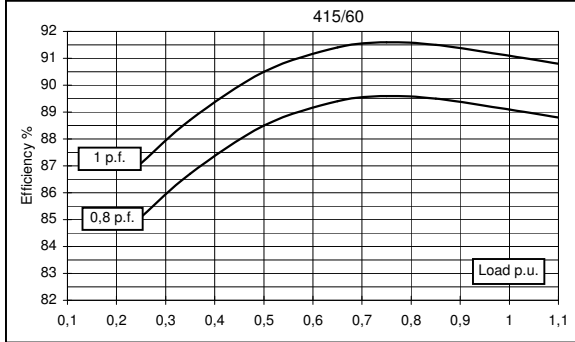

Three phase short circuit decrement curve. No load excitation at rated speed.

This document is a propriety of Mecc Alte S.p.a.. All rights reserved.

TWO BEARING MOMENTS OF INERTIA

FAMCO
 هایپر صنعت

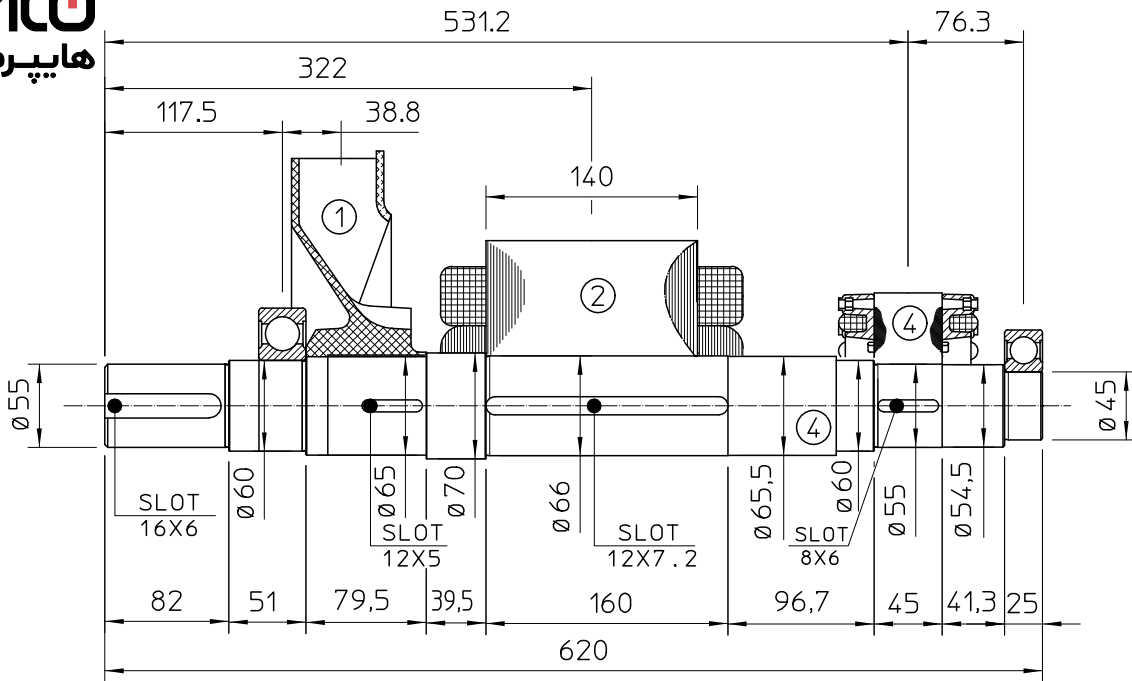

POS.	COMPONENT	WEIGHT (kg)	J (kgm ²)
1	FAN	2.3	0.0224
2	MAIN ROTOR	39.5	0.2804
3	EX. ROTOR	5.4	0.012
4	SHAFT	14.1	0.0069
TOTAL		61.3	0.3217

TWO BEARING DIMENSIONS

FAMCO
 هایپر صنعت

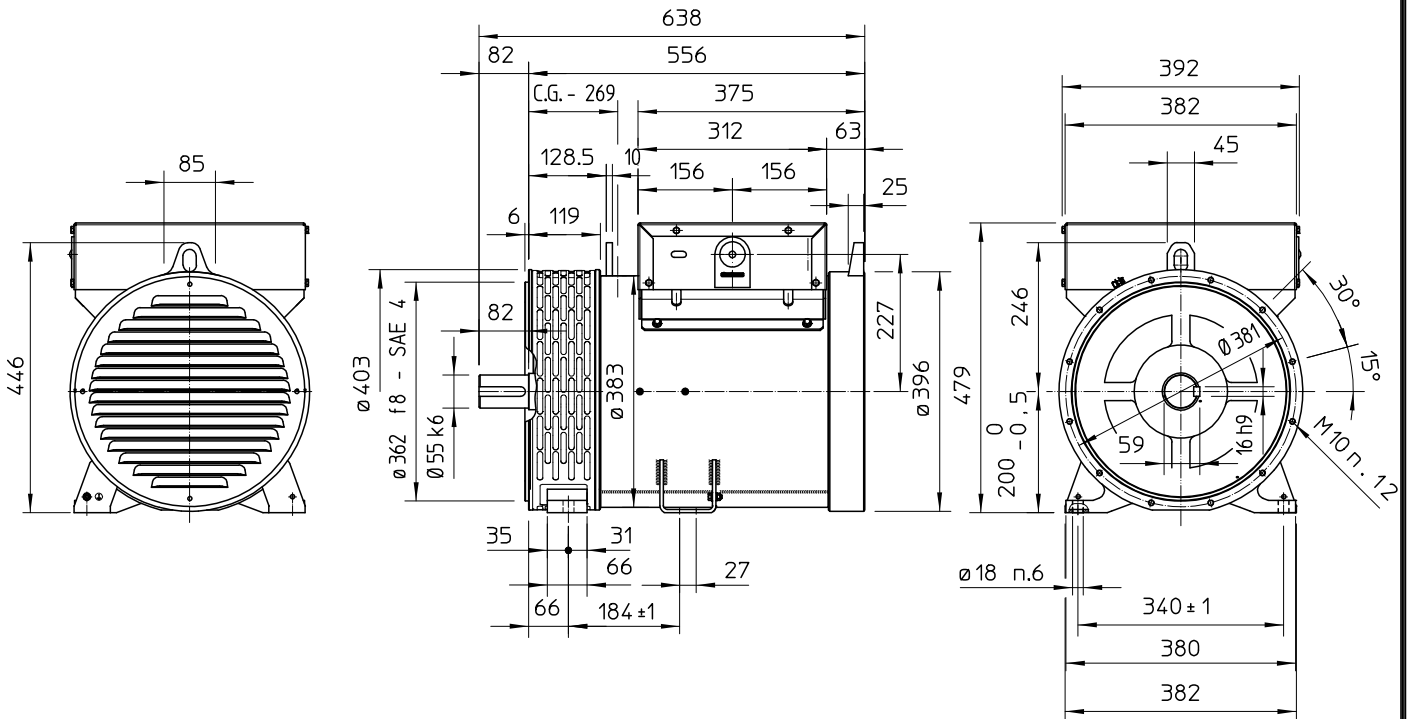

C.G.= GRAVITY CENTER

SINGLE BEARING MOMENTS OF INERTIA

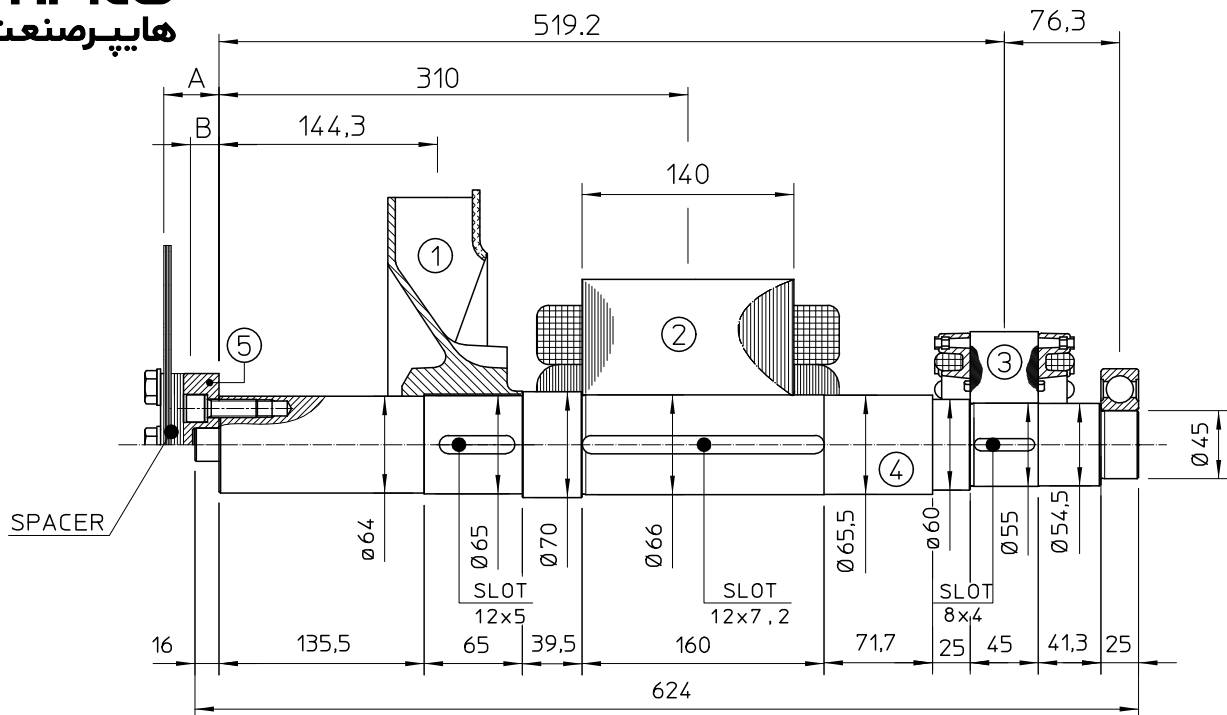

POS.	COMPONENT	WEIGHT (kg)	J (kgm ²)
1	FAN	2.3	0.0224
2	MAIN ROTOR	39.5	0.2804
3	EX. ROTOR	5.4	0.012
4	SHAFT	14.5	0.0074
TOTAL		61.7	0.3222

SAE N°	5		SHAFTS COUPLING FLEX PLATE	
	A	B	WEIGHT kg	J kgm ²
6.5	5	2.5	1.74	0.0084
7.5	5	2.5	2.1	0.013
8	36.6	28.1	3.9	0.02
10	28.6	21.6	4.47	0.038
11.5	15	11.5	4.51	0.059

SINGLE BEARING DIMENSIONS

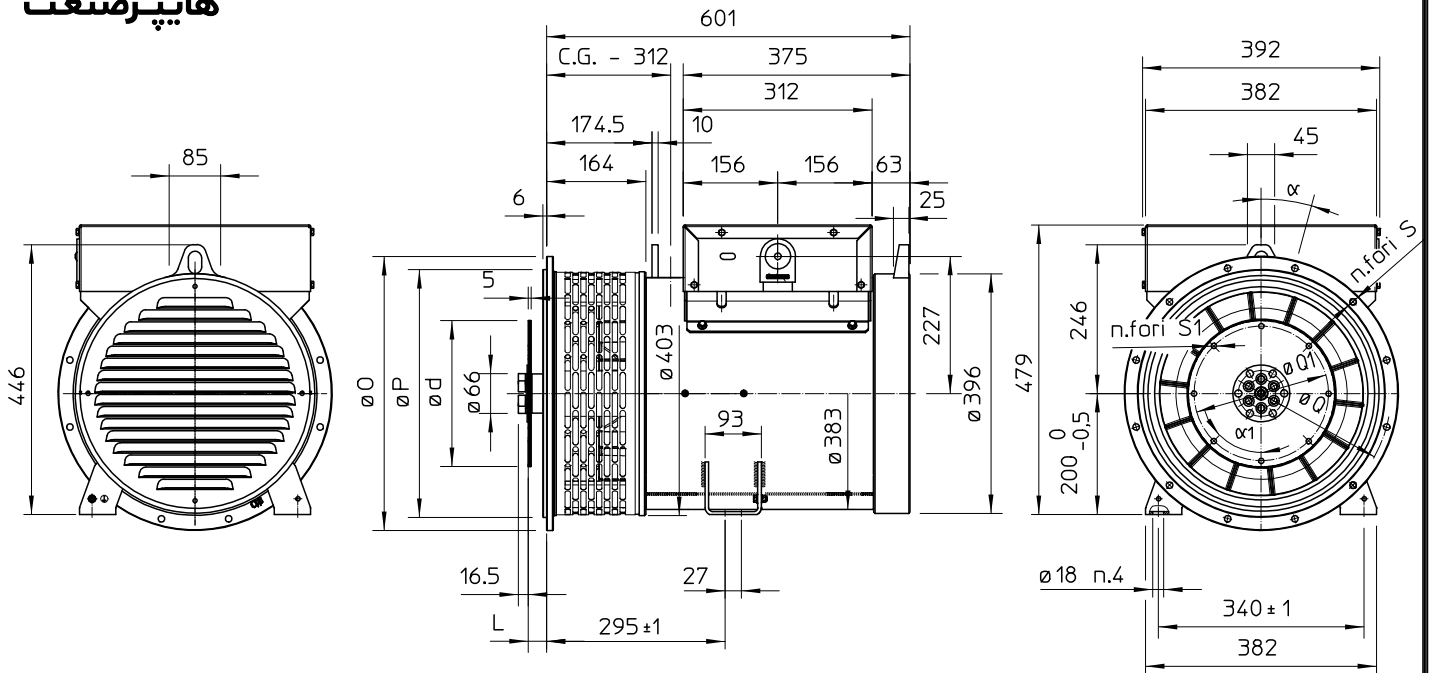

SAE N.	FLANGIA / FLANGE BRIDE / FLANSCH					
	O	P	Q	S	N. FORI HOLES N°	α
5	356	314.3	333.4	11	8	45
4	403	362	381	11	12	30
3	451	409.6	428.6	11	12	30
2	490	447.7	466.7	11	12	30
1	552	511.2	530.2	11	12	30

SAE N.	GIUNTI A DISCHI / DISC COUPLING DISCQUE DE MONOPALIER / SCHEIBENKUPPLUNG					
	d	L	Q1	S1	N. FORI HOLES N°	α1
6 1/2	215.9	30.2	200	9	6	60
7 1/2	241.3	30.2	222.25	9	8	45
8	263.52	62	244.47	11	6	60
10	314.32	53.8	295.27	11	8	45
11 1/2	352.42	39.6	333.37	11	8	45

Electrical Characteristics										
Frequency	Hz	50				60				
Voltage (series star)	V	380	400	415	440	415	440	460	480	
Rated power class H	kVA	75	75	75	70	80	86	90	90	
	kW	60	60	60	56	64	69	72	72	
Rated power class F	kVA	67	67	67	62	73	80	83	83	
	kW	53,6	53,6	53,6	49,6	58,4	64	66,4	66,4	
Regulation with	DSR	±1 % with any power factor and speed variations between -5% +30%								
Insulation class		H								
Execution		Brushless								
Stator winding		12 ends								
Rotor		with damping cage								
Efficiencies class H	4/4	%	90,6	90,7	90,4	90,2	92,5	93	93,1	93,2
(see graph. for details)	3/4	%	90,8	91,1	91	90,7	92,8	93	93,2	93,4
	2/4	%	89,6	89,7	89,7	89,7	90,8	90,9	91	91,1
	1/4	%	87,1	86,9	86,7	86,4	88,1	88,1	88,1	87,9
Reactances (f. l.c.l. F)	Xd	%	338,3	305,4	283,7	235,5	363,1	347,2	332,5	305,4
	Xd'	%	14,84	13,4	12,44	10,33	15,93	15,23	14,58	13,4
	Xd''	%	7,72	7	6,47	5,37	8,28	7,92	7,58	7
	Xq	%	130,6	117,9	109,5	90,9	140,1	134,0	128,3	117,9
	Xq'	%	130,6	117,9	109,5	90,9	140,1	134,0	128,3	117,9
	Xq''	%	38,0	34,3	31,9	26,4	40,8	39,0	37,3	34,3
	X ₂	%	25,88	23,4	21,70	18,02	27,77	26,56	25,43	23,4
	X ₀	%	3,68	3,3	3,09	2,56	3,95	3,78	3,62	3,3
Short Circuit Ratio	Kcc		0,48	0,57	0,64	1,19	0,36	0,40	0,48	0,57
Time Constants	Td'	sec.	0,065							
	Td''	sec.	0,0135							
	Tdo'	sec.	1,30							
	Tα	sec.	0,027							
Short Circuit Current Capacity		%	>300				>350			
Excitation at no load	Amp.		0,5	0,6	0,7	1,2	0,25	0,3	0,4	0,5
Excitation at full load	Amp.		2,1	2,2	2,4	2,8	1,8	1,7	1,9	2,1
Overload (long-term)	%	1 hour in a 6 hours period 110% rated load								
Overload per 20 sec.	%	300								
Stator Winding Resistance (20°C)	Ω	0,035								
Rotor Winding Resistance (20°C)	Ω	3,171								
Exciter Resistance (20 °C)	Ω	Rotor : 0,442				Stator : 11,35				
Heat dissipation at f.l.c.l.H	W	6225	6152	6372	6084	5189	5178	5336	5253	
Telephone Interference		THF < 2%				TIF < 45				
Radio interference		EN61000-6-3, EN61000-6-1. For others standards apply to factory								
Waveform Distors.(THD) at f. load	LL/LN %	3,9 / 3,7								
Waveform Distors.(THD) at no load	LL/LN %	3,3 / 3,1								
Mechanical characteristics										
Protection		IP 21 (other protection on request)								
DE bearing		6312-2RS								
NDE bearing		6309-2RS								
Weight of wound stator assembly	kg	110								
Weight of wound rotor assembly	kg	74								
Weight of complete generator	kg	298								
Maximun overspeed	rpm	2250								
Unbalanced magnetic pull at f.l.c.l.F	kN/mm	5,2								
Cooling air requirement	m ³ /min	11,8				14,5				
Inertia Constant (H)	sec.	0,094				0,113				
Noise level at 1m/7m	dB(A)	75 / 60				79 / 64				

All technical data are to be considered as a reference and they can be modified without any notice.

This document is a propriety of Mecc Alte S.p.a..All rights reserved.

50 Hz

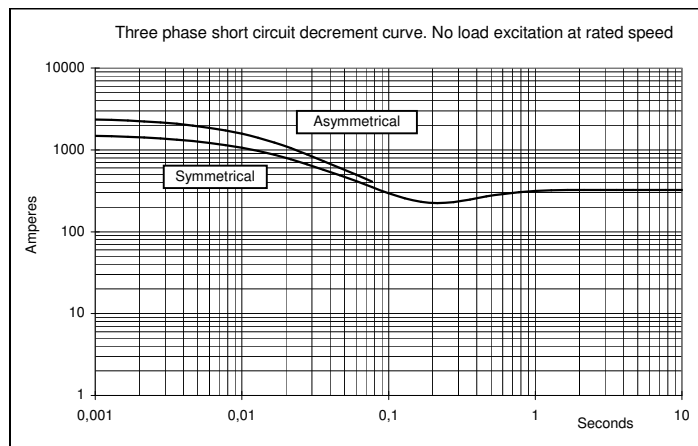
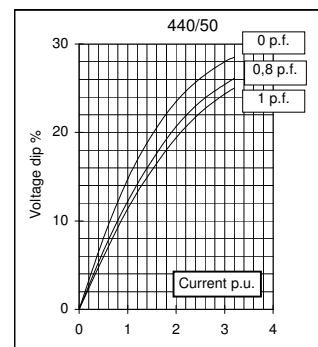
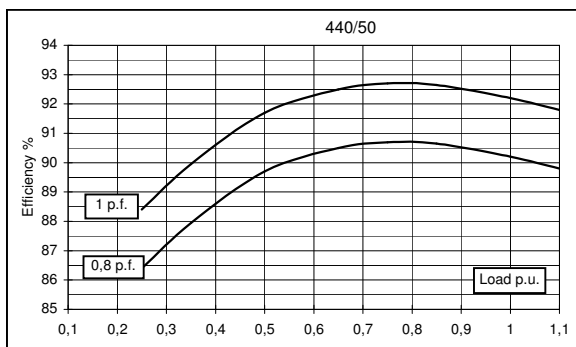
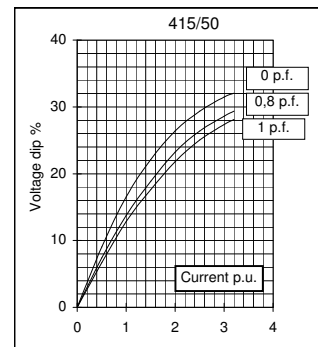
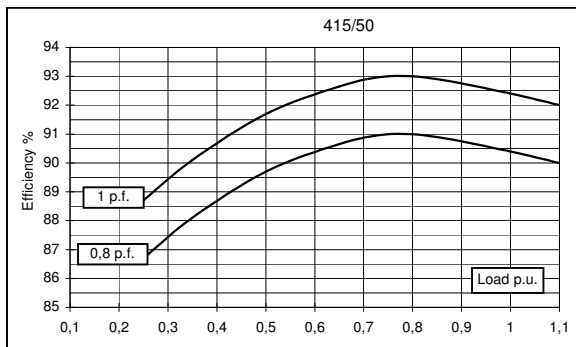
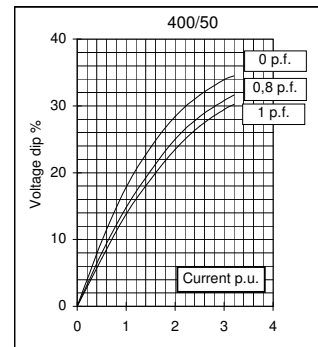
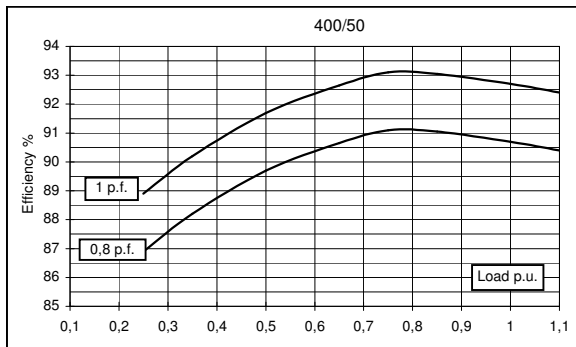
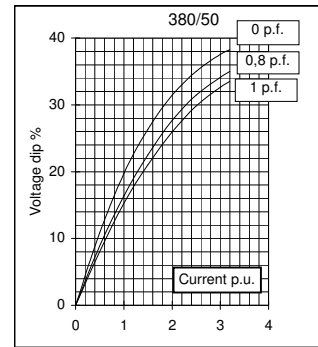
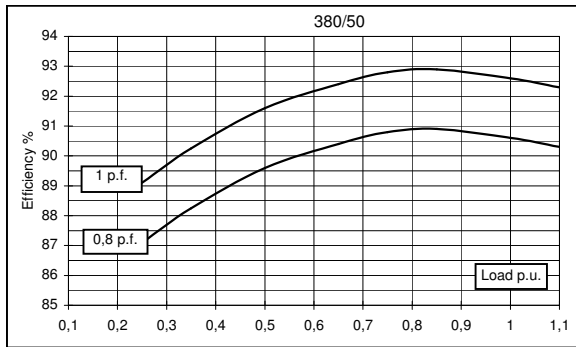

This document is a propriety of Mecc Alte S.p.a.. All rights reserved.

60 Hz

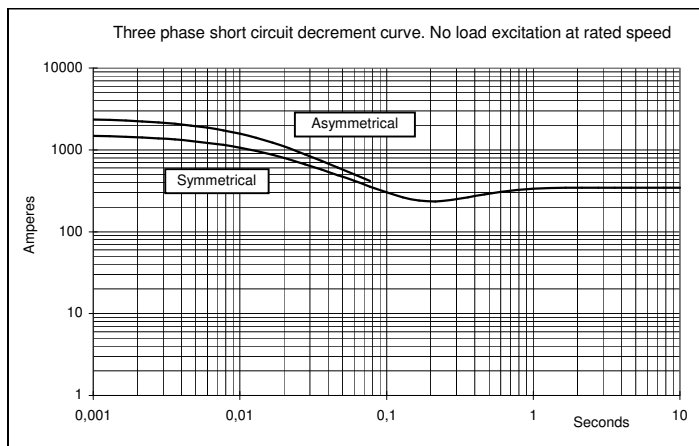
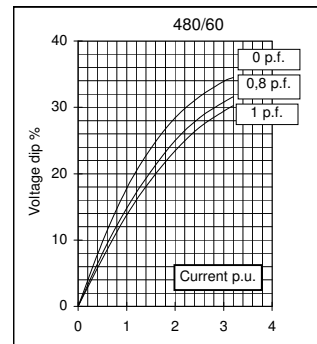
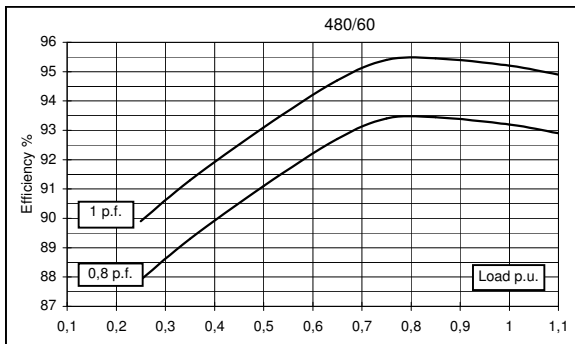
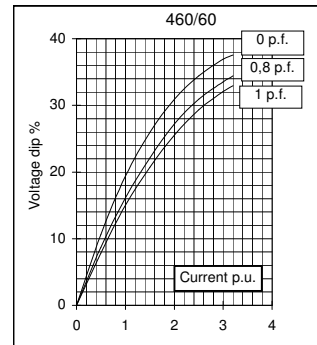
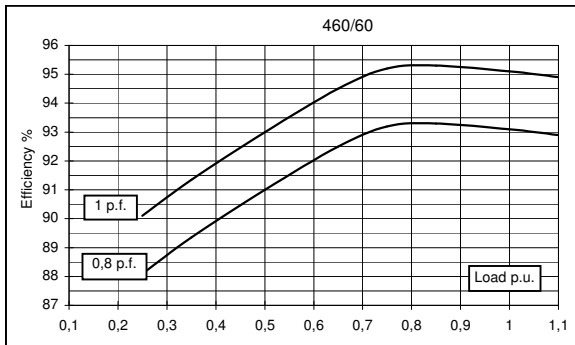
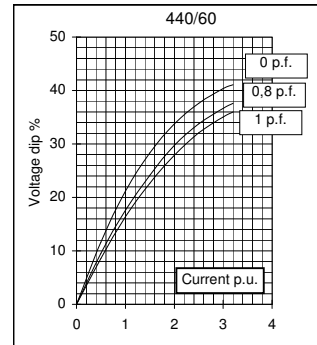
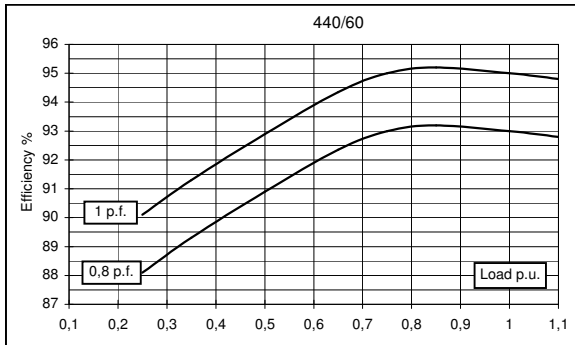
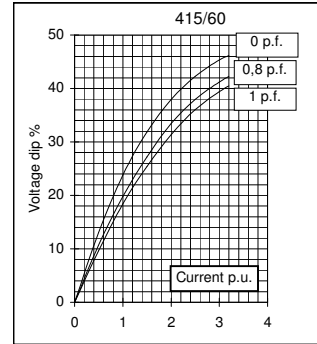
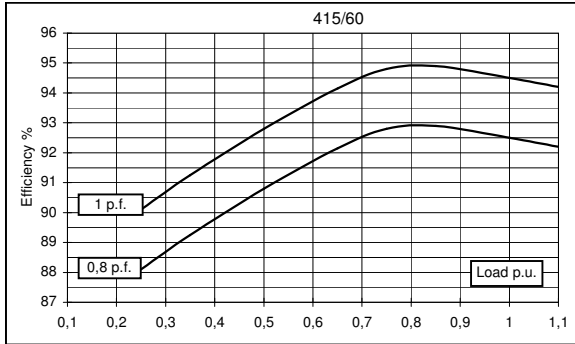

This document is a propriety of Mecc Alte S.p.a.. All rights reserved.

TWO BEARING MOMENTS OF INERTIA

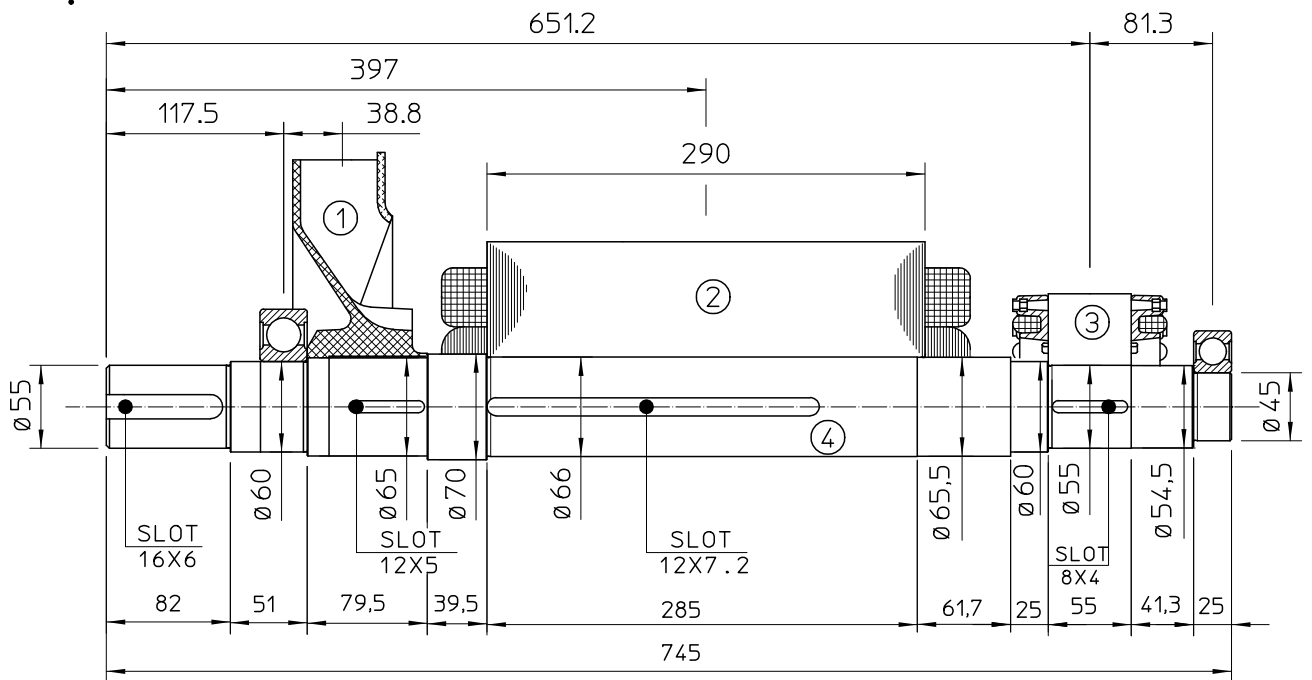

POS.	COMPONENT	WEIGHT (kg)	J (kgm ²)
1	FAN	2.3	0.0224
2	MAIN ROTOR	74	0.5254
3	EX. ROTOR	7	0.016
4	SHAFT	17.3	0.0067
TOTAL		100.6	0.5705

TWO BEARING DIMENSIONS

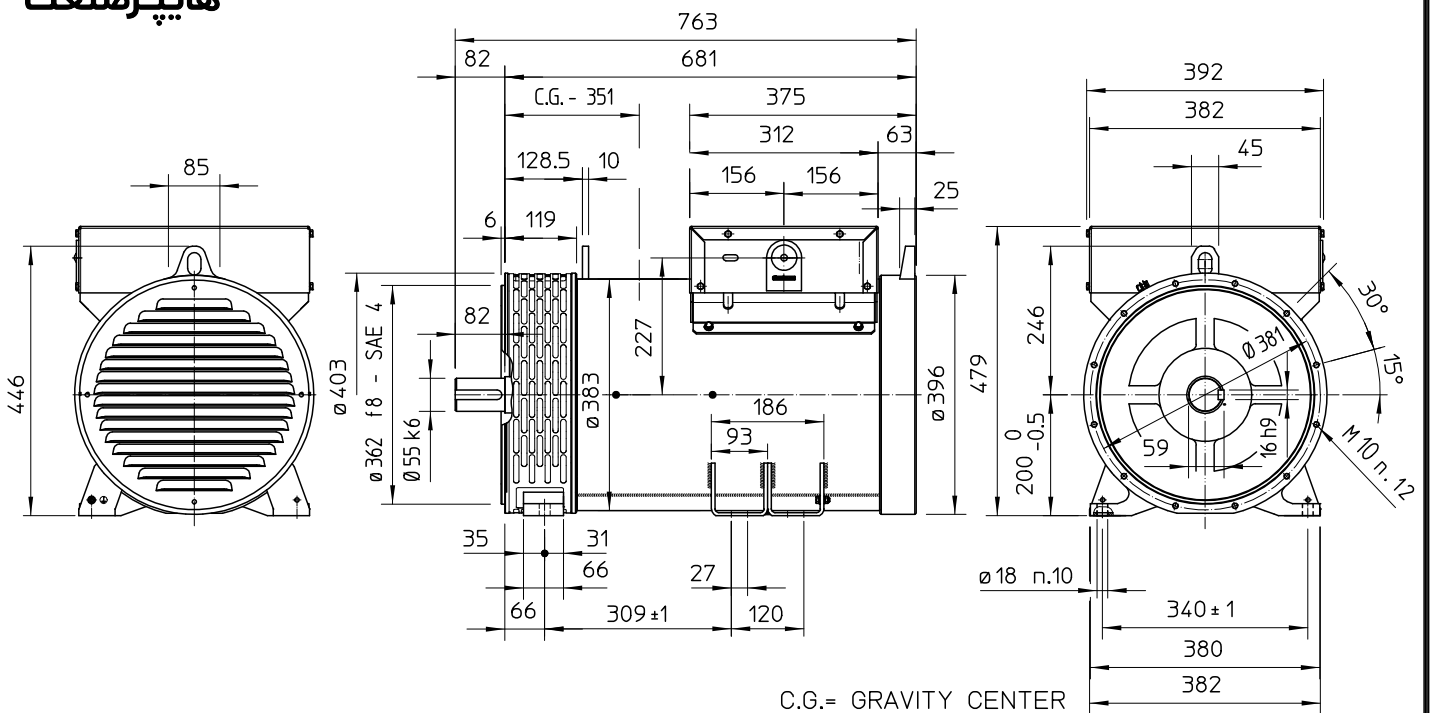

C.G.= GRAVITY CENTER

SINGLE BEARING MOMENTS OF INERTIA

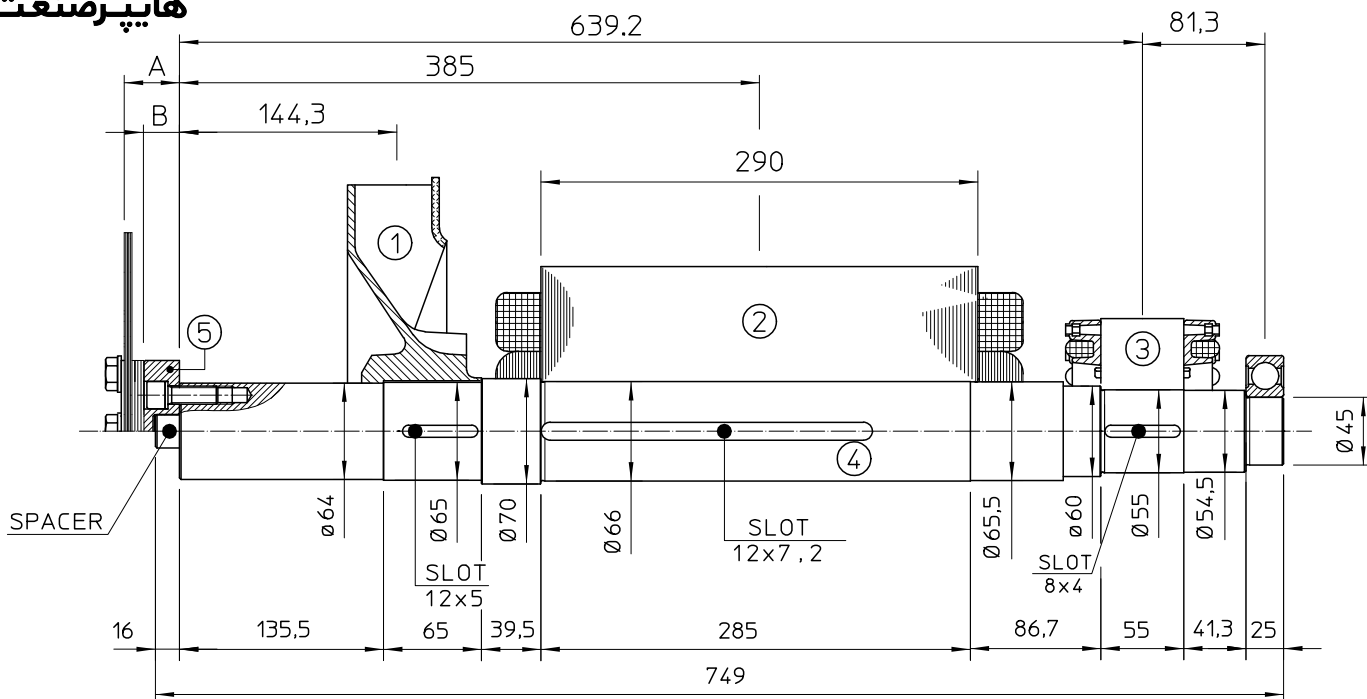

POS.	COMPONENT	WEIGHT (kg)	J (kgm ²)
1	FAN	2.3	0.0224
2	MAIN ROTOR	74	0.5254
3	EX. ROTOR	7	0.016
4	SHAFT	17.6	0.0090
TOTAL		100.9	0.5728

SAE N°	5		SHAFTS COUPLING FLEX PLATE	
	A	B	WEIGHT kg	J kgm ²
6.5	5	2.5	1.74	0.0084
7.5	5	2.5	2.1	0.013
8	36.6	28.1	3.9	0.02
10	28.6	21.6	4.47	0.038
11.5	15	11.5	4.51	0.059

SINGLE BEARING DIMENSIONS

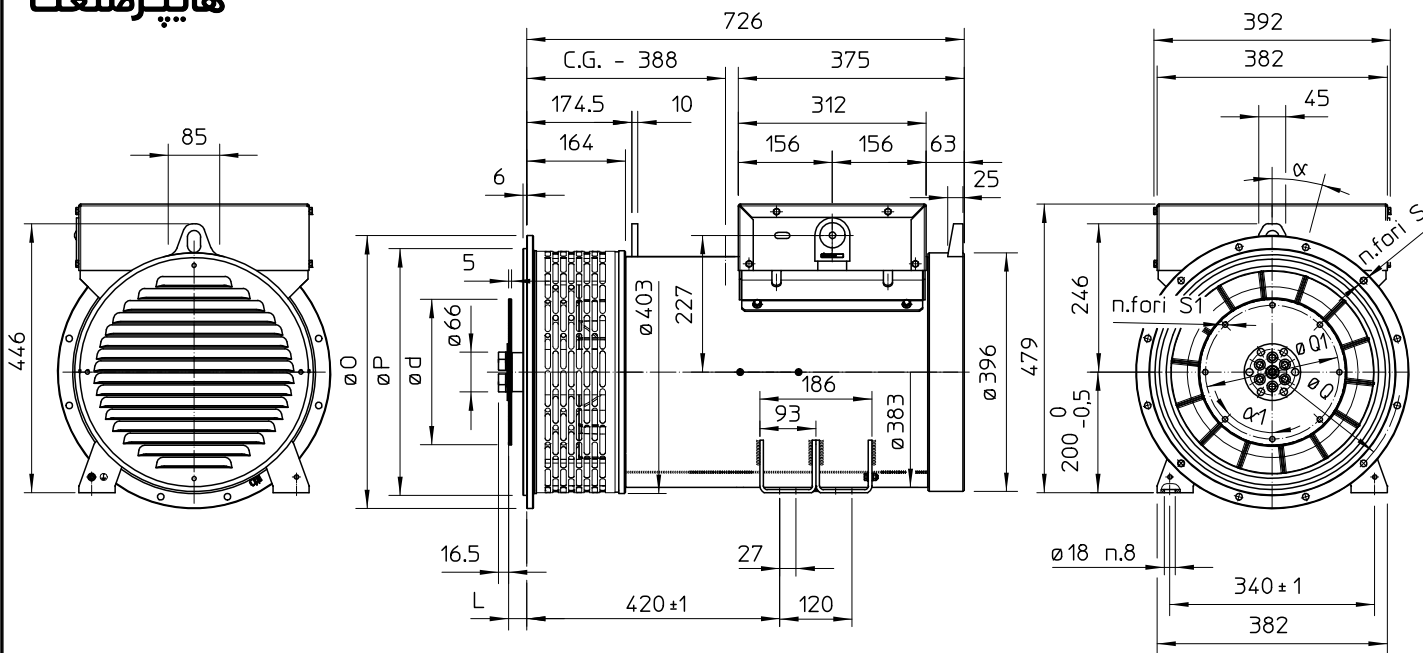

SAE N.	FLANGIA / FLANGE BRIDE / FLANSCH					
	O	P	Q	S	N. FORI HOLES N°	α
5	356	314.3	333.4	11	8	45
4	403	362	381	11	12	30
3	451	409.6	428.6	11	12	30
2	490	447.7	466.7	11	12	30
1	552	511.2	530.2	11	12	30

SAE N.	GIUNTI A DISCHI / DISC COUPLING DISCQUE DE MONOPALIER / SCHEIBENKUPPLUNG					
	d	L	Q1	S1	N. FORI HOLES N°	α1
6 1/2	215.9	30.2	200	9	6	60
7 1/2	241.3	30.2	222.25	9	8	45
8	263.52	62	244.47	11	8	60
10	314.32	53.8	295.27	11	8	45
11 1/2	352.42	39.6	333.37	11	8	45

Electrical Characteristics										
Frequency	Hz	50				60				
Voltage (series star)	V	380	400	415	440	415	440	460	480	
Rated power class H	kVA	42,5	42,5	42,5	34	50	51	51	51	
	kW	34	34	34	27,2	40	40,8	40,8	40,8	
Rated power class F	kVA	39	39	39	31	46	49	49	49	
	kW	31,2	31,2	31,2	25	37	39,2	39,2	39,2	
Regulation with	DSR	±1 % with any power factor and speed variations between -5% +30%								
Insulation class		H								
Execution		Brushless								
Stator winding		12 ends								
Rotor		with damping cage								
Efficiencies class H	4/4	%	88,5	88,6	88,3	88,1	89,1	89,6	89,8	90
(see graph. for details)	3/4	%	88,8	89,1	89	88,7	89,9	90,2	90,4	90,6
	2/4	%	87,2	87,3	87,3	87,3	88,7	88,8	88,9	89
	1/4	%	84,9	85	84,8	84,3	87	87	87	87
Reactances (f. l.cl. F)	Xd	%	210,5	190	176,5	125,6	249,2	226,1	206,9	190
	Xd'	%	15,84	14,3	13,28	9,45	18,76	17,02	15,57	14,3
	Xd''	%	11,08	10	9,29	6,61	13,12	11,90	10,89	10
	Xq	%	108,6	98	91,0	64,8	128,5	116,6	106,7	98
	Xq'	%	108,6	98	91,0	64,8	128,5	116,6	106,7	98
	Xq''	%	33,9	30,6	28,4	20,2	40,1	36,4	33,3	30,6
	X ₂	%	23,82	21,5	19,97	14,21	28,20	25,59	23,41	21,5
	X ₀	%	2,99	2,7	2,51	1,79	3,54	3,21	2,94	2,7
Short Circuit Ratio	Kcc		0,70	0,80	0,90	1,30	0,40	0,60	0,70	0,80
Time Constants	Td'	sec.	0,061							
	Td''	sec.	0,015							
	Tdo'	sec.	1,32							
	Tα	sec.	0,031							
Short Circuit Current Capacity		%	>300				>350			
Excitation at no load	Amp.		0,6	0,7	1	1,3	0,3	0,4	0,5	0,6
Excitation at full load	Amp.		2,3	2,4	2,6	2,9	2,1	2	2,2	2,3
Overload (long-term)		%	1 hour in a 6 hours period 110% rated load							
Overload per 20 sec.		%	300							
Stator Winding Resistance (20 °C)	Ω		0,078							
Rotor Winding Resistance (20 °C)	Ω		2,163							
Exciter Resistance (20 °C)	Ω		Rotor : 0,417				Stator : 10,6			
Heat dissipation at f.l.cl.H	W		4418	4375	4505	3674	4893	4736	4634	4533
Telephone Interference			THF < 2%				TIF < 45			
Radio interference			EN61000-6-3, EN61000-6-1. For others standards apply to factory							
Waveform Distors.(THD) at f. load	LL/LN %		3,7 / 3,6							
Waveform Distors.(THD) at no load	LL/LN %		3,2 / 3,1							
Mechanical characteristics										
Protection			IP 21 (other protection on request)							
DE bearing			6312-2RS							
NDE bearing			6309-2RS							
Weight of wound stator assembly	kg		62,5							
Weight of wound rotor assembly	kg		43,5							
Weight of complete generator	kg		214							
Maximun overspeed	rpm		2250							
Unbalanced magnetic pull at f.l.cl.F	kN/mm		4,5							
Cooling air requirement	m ³ /min		11,8				14,5			
Inertia Constant (H)	sec.		0,102				0,122			
Noise level at 1m/7m	dB(A)		75 / 60				79 / 64			

All technical data are to be considered as a reference and they can be modified without any notice.

50 Hz

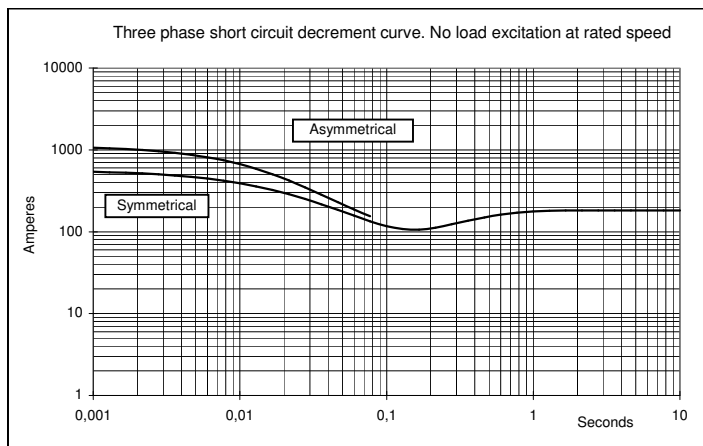
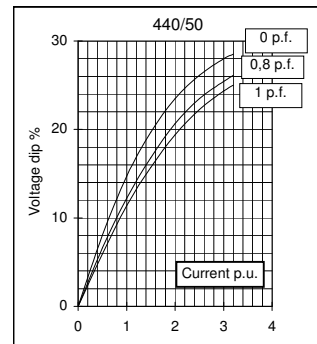
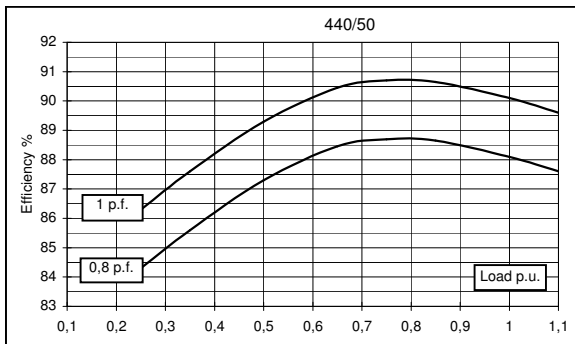
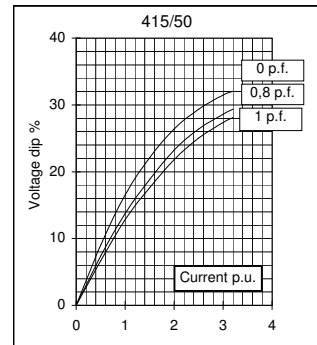
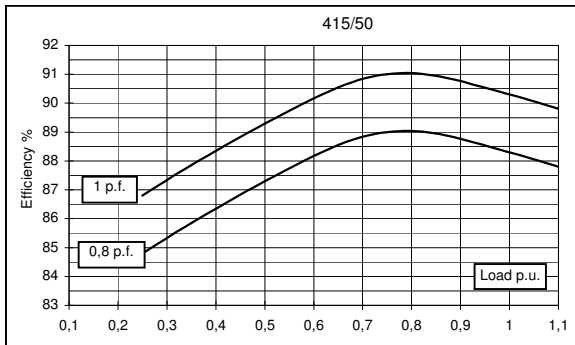
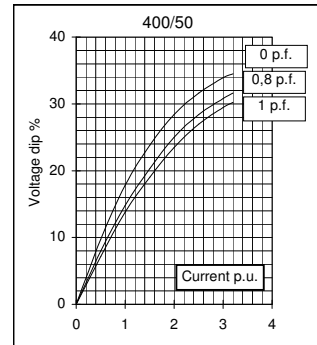
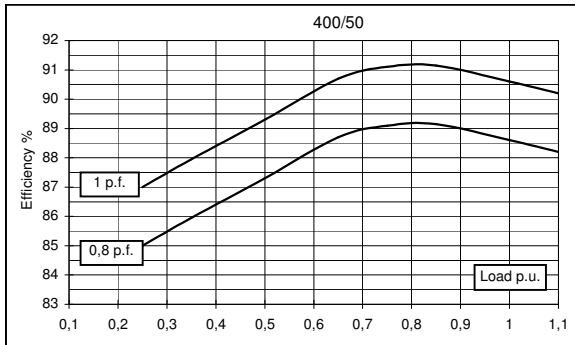
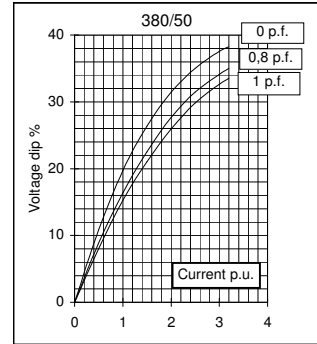
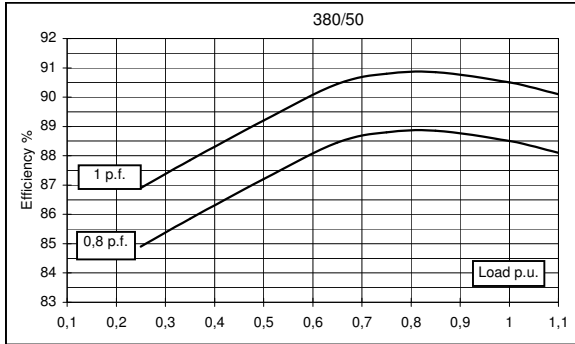

This document is a propriety of Mecc Alte S.p.a.. All rights reserved.

60 Hz

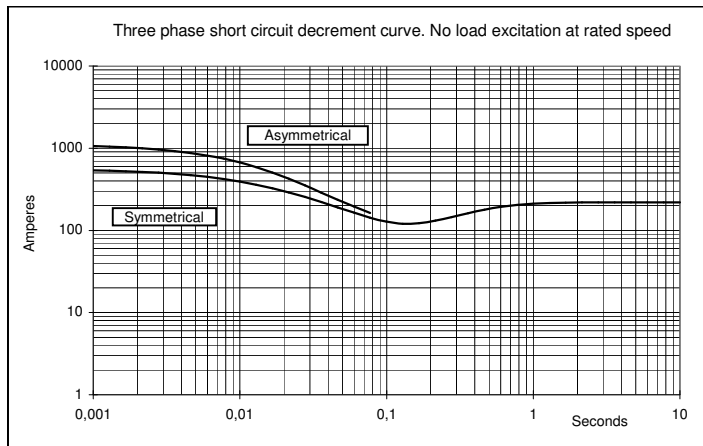
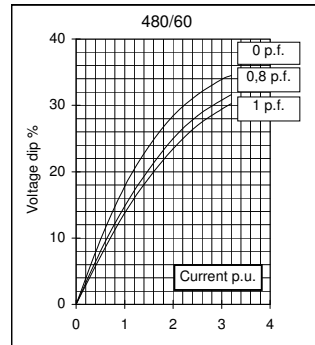
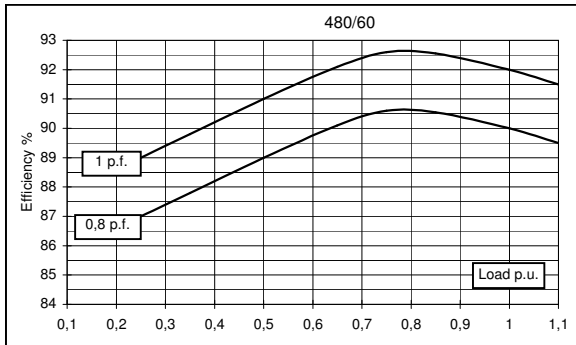
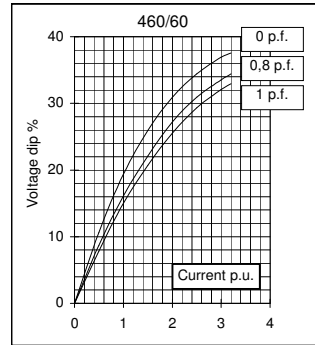
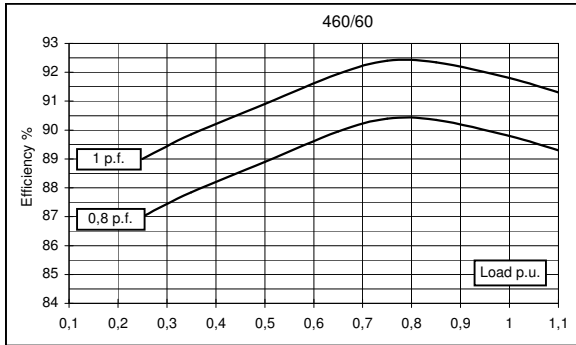
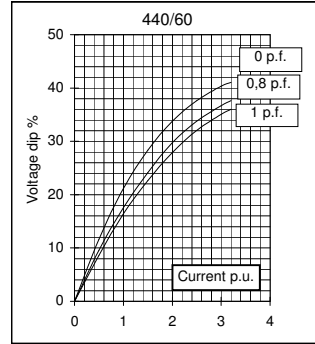
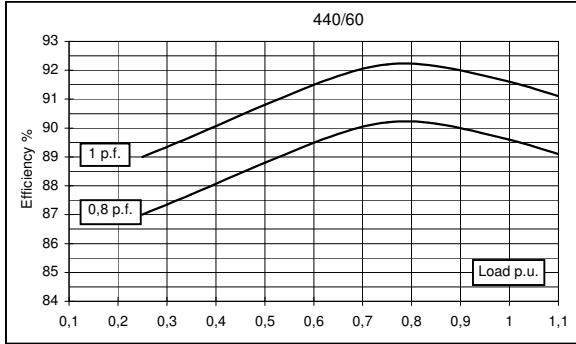
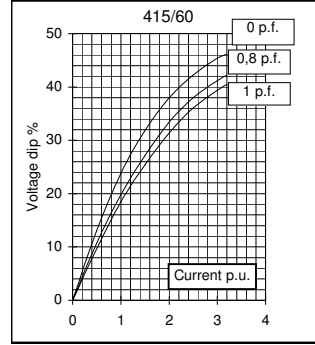
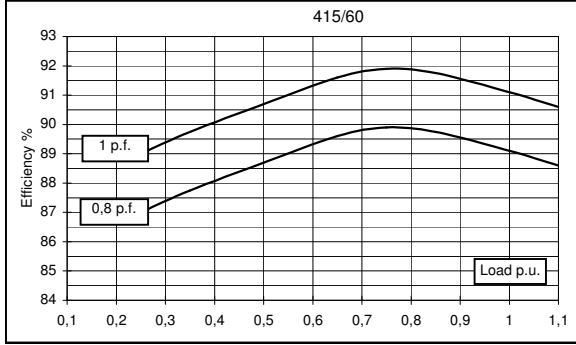

This document is a propriety of Mecc Alte S.p.a.. All rights reserved.

TWO BEARING MOMENTS OF INERTIA

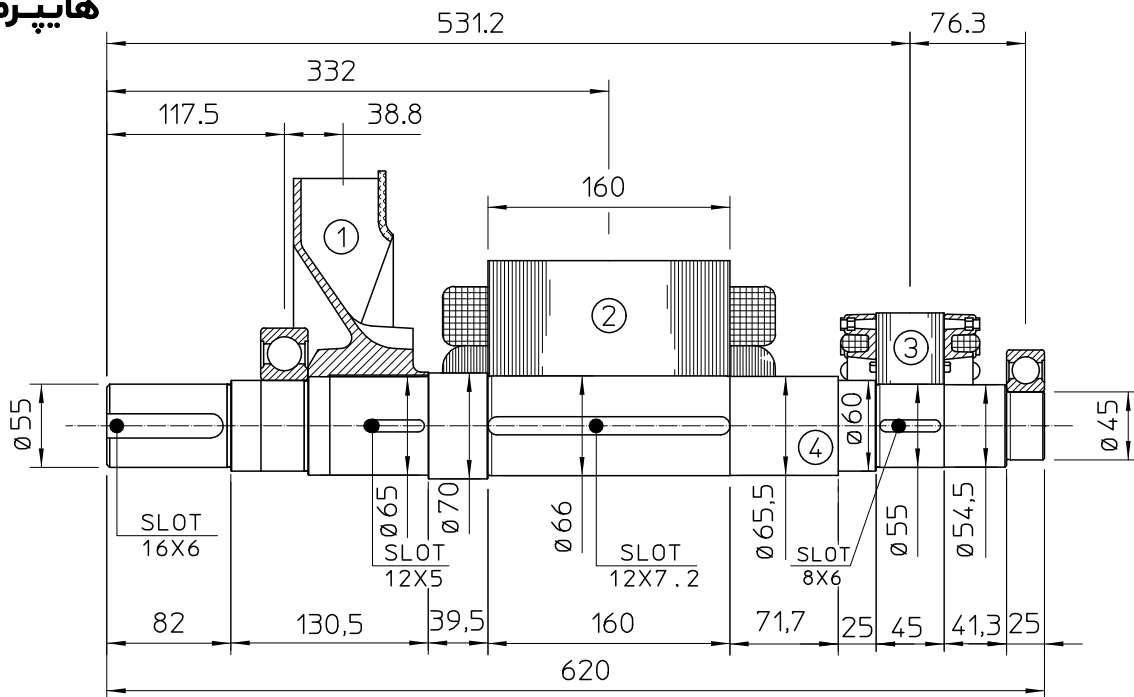

POS.	COMPONENT	WEIGHT (kg)	J (kgm ²)
1	FAN	2.3	0.0224
2	MAIN ROTOR	43.5	0.3088
3	EX. ROTOR	5.4	0.012
4	SHAFT	14.1	0.0069
TOTAL		65.3	0.3501

TWO BEARING DIMENSIONS

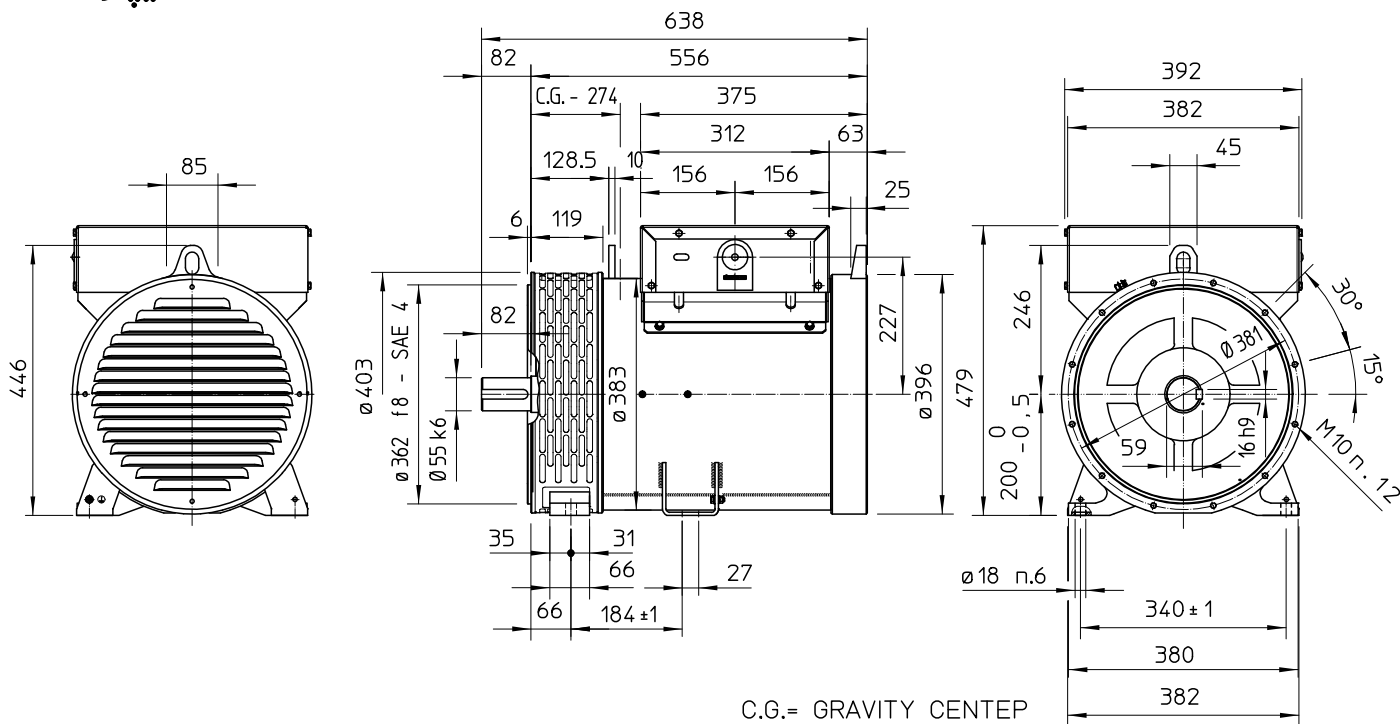

C.G.= GRAVITY CENTER

SINGLE BEARING MOMENTS OF INERTIA

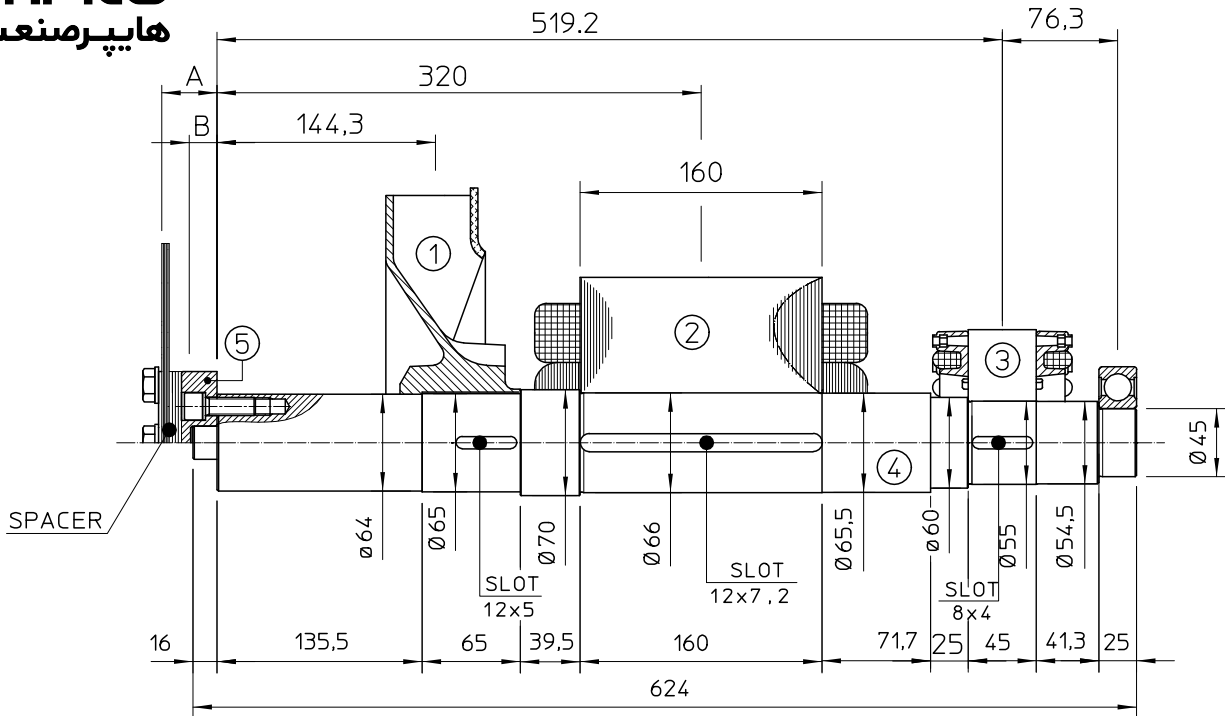

POS.	COMPONENT	WEIGHT (kg)	J (kgm ²)
1	FAN	2.3	0.0224
2	MAIN ROTOR	43.5	0.3088
3	EX. ROTOR	5.4	0.012
4	SHAFT	14.5	0.0074
TOTAL		65.7	0.3506

SAE N°	5		SHAFTS COUPLING FLEX PLATE	
	A	B	WEIGHT kg	J kgm ²
6.5	5	2.5	1.74	0.0084
7.5	5	2.5	2.1	0.013
8	36.6	28.1	3.9	0.02
10	28.6	21.6	4.47	0.038
11.5	15	11.5	4.51	0.059

SINGLE BEARING DIMENSIONS

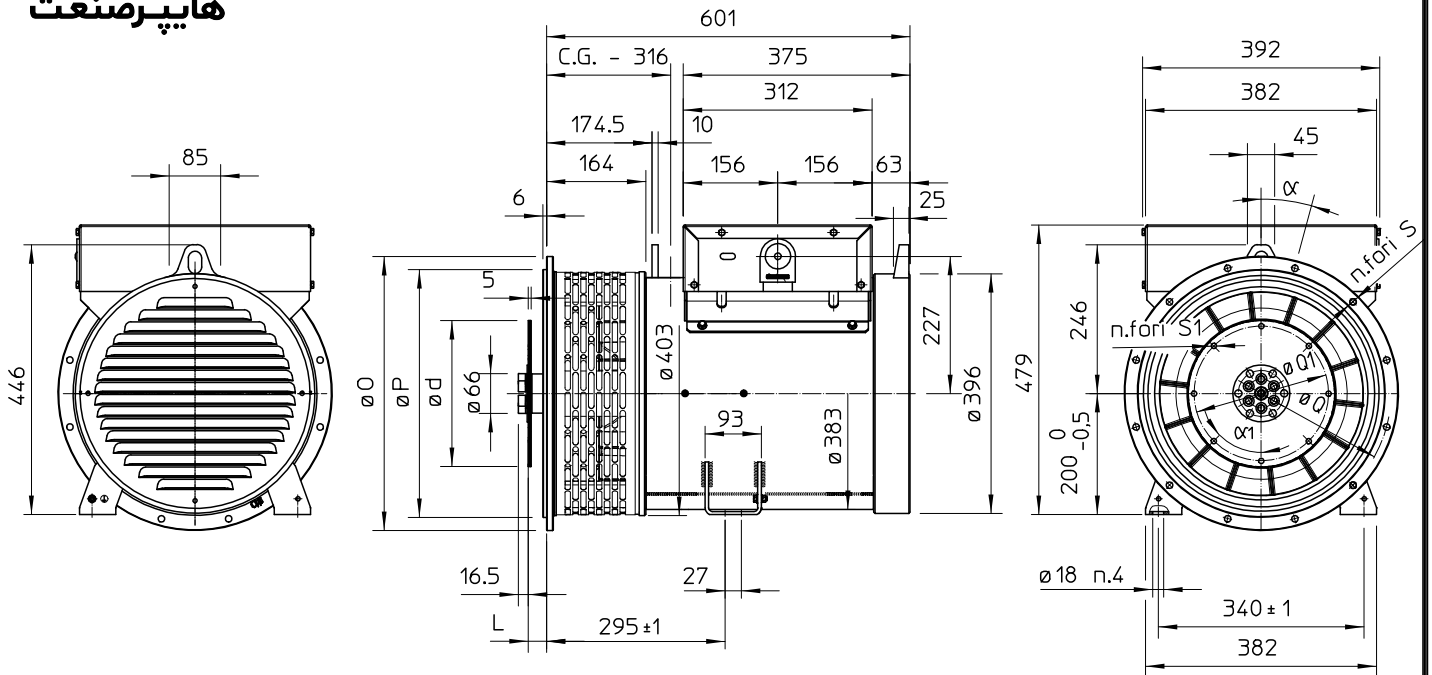

SAE N.	FLANGIA / FLANGE BRIDE / FLANSCH					
	O	P	Q	S	N. FORI HOLES N°	α
5	356	314.3	333.4	11	8	45
4	403	362	381	11	12	30
3	451	409.6	428.6	11	12	30
2	490	447.7	466.7	11	12	30
1	552	511.2	530.2	11	12	30

SAE N.	GIUNTI A DISCHI / DISC COUPLING DISCQUE DE MONOPALIER / SCHEIBENKUPPLUNG					
	d	L	Q1	S1	N. FORI HOLES N°	α1
6 1/2	215.9	30.2	200	9	6	60
7 1/2	241.3	30.2	222.25	9	8	45
8	263.52	62	244.47	11	6	60
10	314.32	53.8	295.27	11	8	45
11 1/2	352.42	39.6	333.37	11	8	45

C.G.= GRAVITY CENTER

Electrical Characteristics										
Frequency	Hz	50				60				
Voltage (series star)	V	380	400	415	440	415	440	460	480	
Rated power class H	kVA	85	85	85	70	95	102	102	102	
	kW	68	68	68	56	76	81,6	81,6	81,6	
Rated power class F	kVA	77	77	77	63	85,5	92	92	92	
	kW	61,6	61,6	61,6	50,4	68,4	73,6	73,6	73,6	
Regulation with SR7/2		±1,5 % with any power factor and speed variations between -5% +30%								
Insulation class		H								
Execution		Brushless								
Stator winding		12 ends								
Rotor		with damping cage								
Efficiencies class H	4/4	%	91,4	91,5	91,2	91	92,7	93,2	93,3	93,4
(see graph. for details)	3/4	%	91,6	91,9	91,8	91,5	93,3	93,5	93,6	93,8
	2/4	%	89,9	90	90	89,8	91,5	91,6	91,7	91,8
	1/4	%	86,2	86	85,8	85,8	87,7	87,7	87,7	87,5
Reactances (f. l.cl. F)	Xd	%	360,1	325	301,9	221,2	404,9	386,8	353,9	325
	Xd'	%	24,7	22,3	20,7	15,2	27,8	26,5	24,3	22,3
	Xd''	%	8,2	7,4	6,9	5,0	9,2	8,8	8,1	7,4
	Xq	%	188,9	170,5	158,4	116,0	212,4	202,9	185,6	170,5
	Xq'	%	188,9	170,5	158,4	116,0	212,4	202,9	185,6	170,5
	Xq''	%	32,7	29,5	27,4	20,1	36,8	35,1	32,1	29,5
	X ₂	%	21,3	19,2	17,8	13,1	23,9	22,8	20,9	19,2
	X ₀	%	4,0	3,6	3,3	2,5	4,5	4,3	3,9	3,6
Short Circuit Ratio	Kcc		0,45	0,50	0,62	1,07	0,35	0,40	0,45	0,50
Time Constants	Td'	sec.	0,04192							
	Td''	sec.	0,00575							
	Tdo'	sec.	1,50							
	Tα	sec.	0,0154							
Short Circuit Current Capacity		%	>300				>350			
Excitation at no load	Amp.		0,4	0,5	0,7	1	0,2	0,3	0,4	0,7
Excitation at full load	Amp.		2,2	2,3	2,5	2,8	1,9	2	2,1	2,2
Overload (long-term)		%	1 hour in a 6 hours period 110% rated load							
Overload per 20 sec.		%	300							
Stator Winding Resistance (20°C)		Ω	0,03							
Rotor Winding Resistance (20°C)		Ω	2,477							
Exciter Resistance (20 °C)		Ω	Rotor : 0,410				Stator : 15,28			
Heat dissipation at f.l.cl.H	W		6398	6317	6561	5538	5985	5954	5860	5766
Telephone Interference			THF < 2%				TIF < 40			
Radio interference			EN50081-1; EN50082-1; VDE0875K. For others standards apply to factory							
Waveform Distors.(THD) at f. load	LL/LN %		1,6 / 1,8							
Waveform Distors.(THD) at no load	LL/LN %		2,9 / 3							
Mechanical characteristics										
Protection			IP 21 (other protection on request)							
DE bearing			6314.2RS							
NDE bearing			6311.2RS							
Weight of wound stator assembly	kg		97							
Weight of wound rotor assembly	kg		63							
Weight of complete generator	kg		341							
Maximun overspeed	rpm		2250							
Unbalanced magnetic pull at f.l.cl.F	kN/mm		4,9							
Cooling air requirement	m ³ /min		19,3				23			
Inertia Constant (H)	sec.		0,111				0,133			
Noise level at 1m/7m	dB(A)		79 / 65				83 / 69			

All technical data are to be considered as a reference and they can be modified without any notice.

This document is a propriety of Mecc Alte S.p.a..All rights reserved.

50 Hz

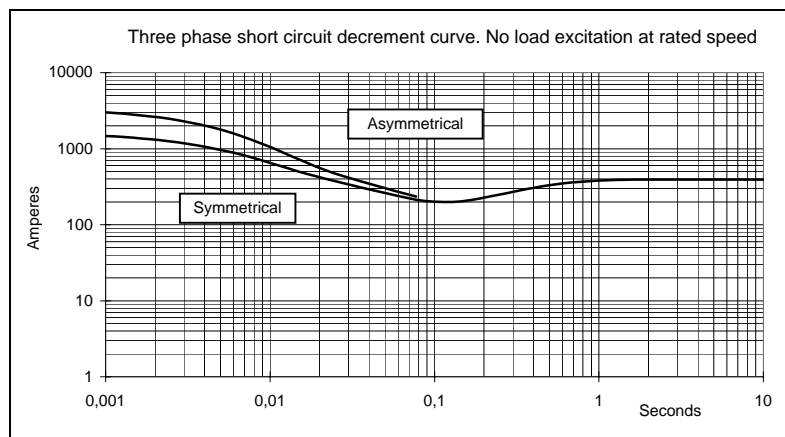
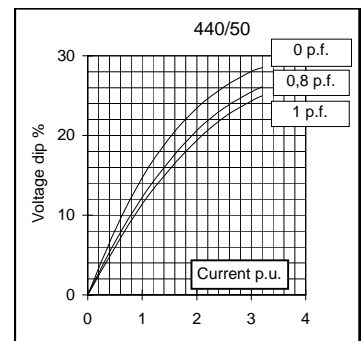
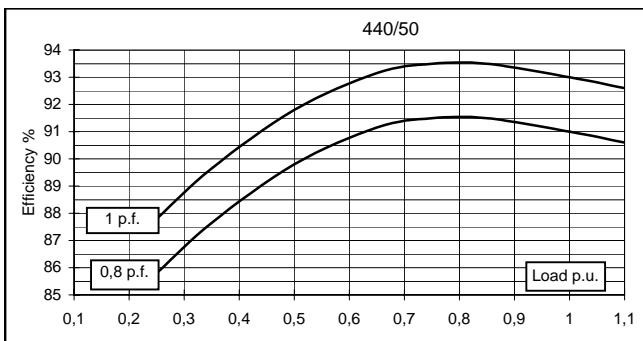
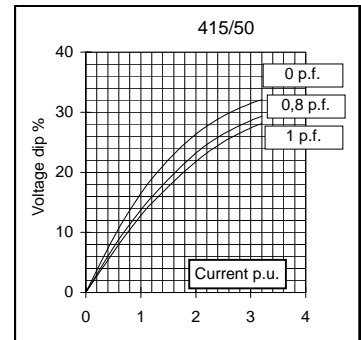
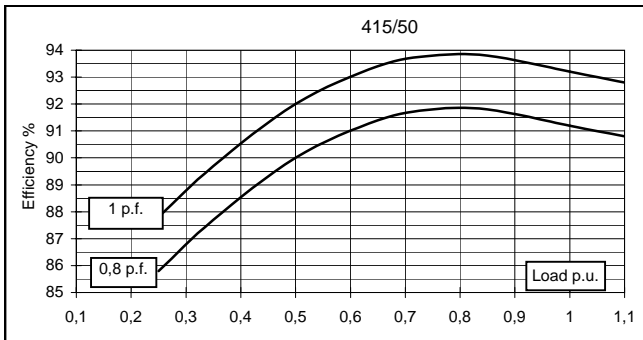
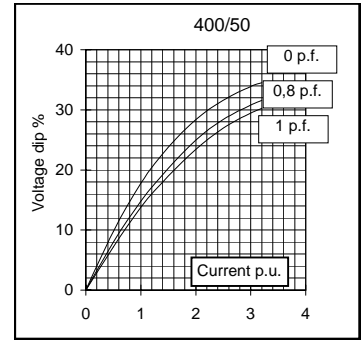
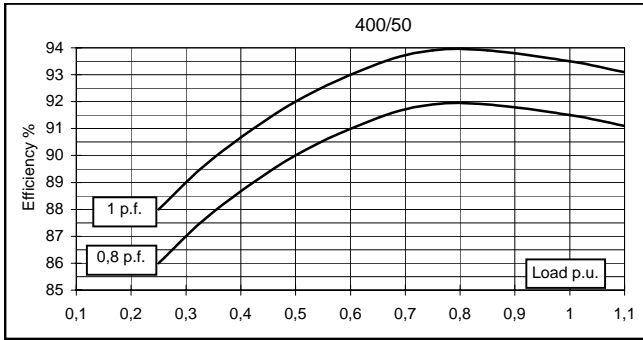
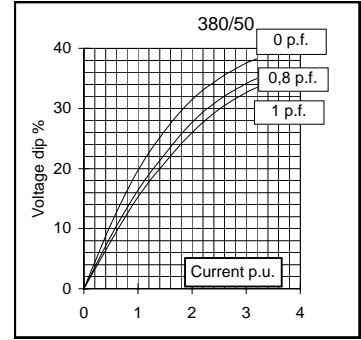
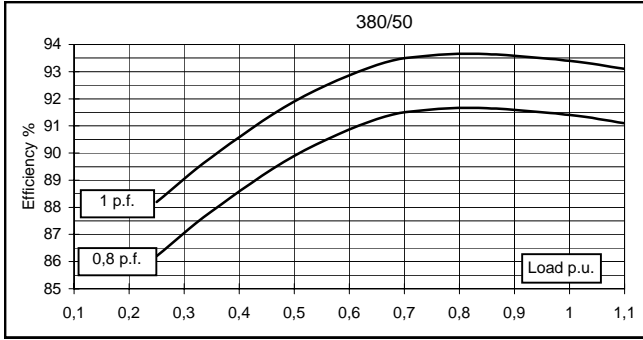

This document is a propriety of Mecc Alte S.p.a.. All rights reserved.

60 Hz

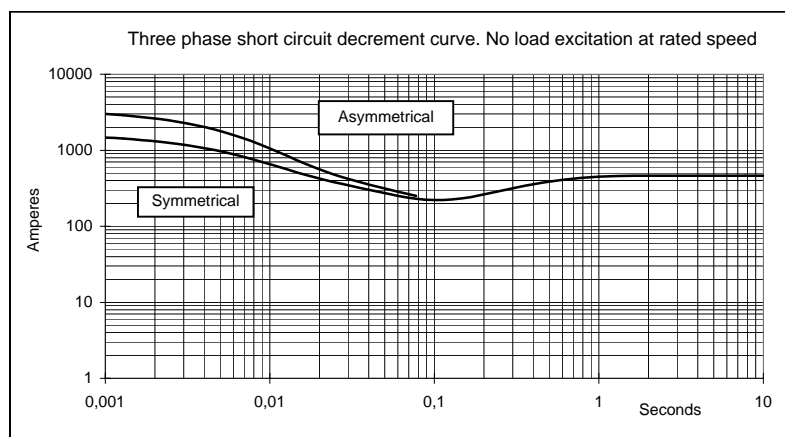
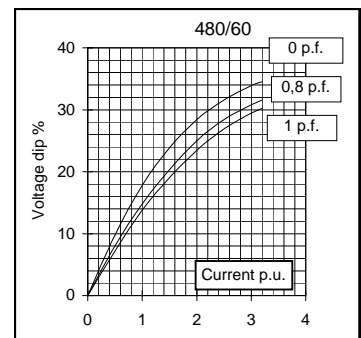
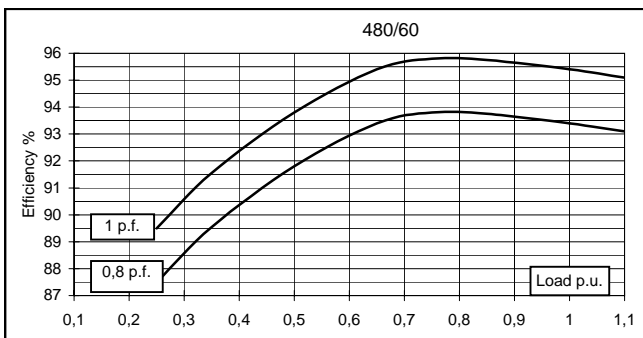
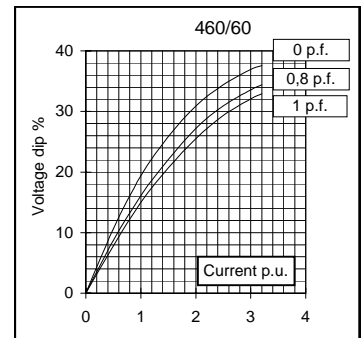
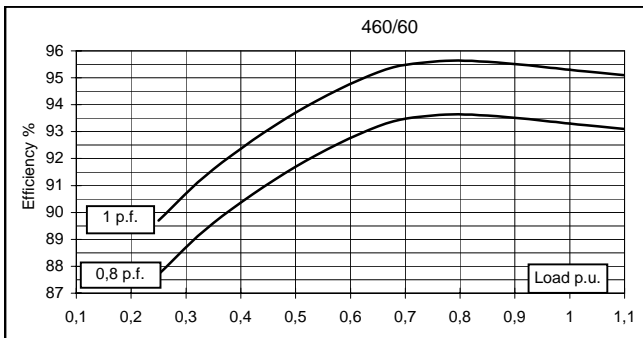
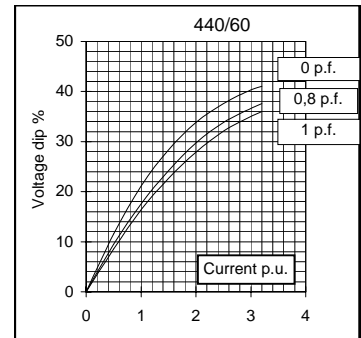
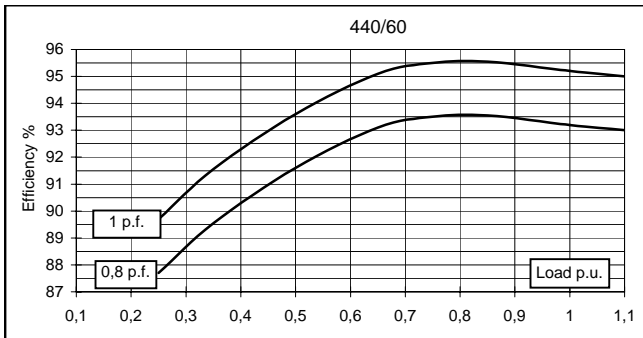
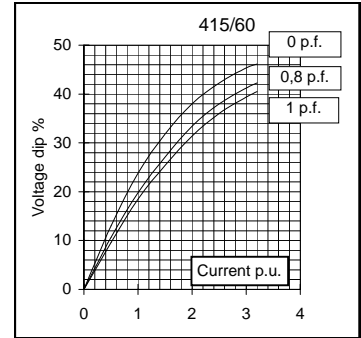
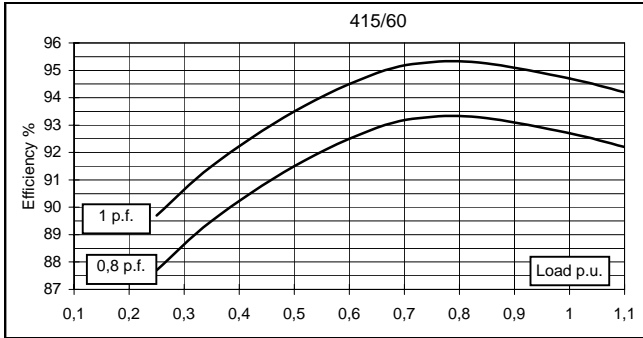

This document is a propriety of Mecc Alte S.p.a.. All rights reserved.

FAMCO
هایپر صنعت

TWO BEARING MOMENTS OF INERTIA

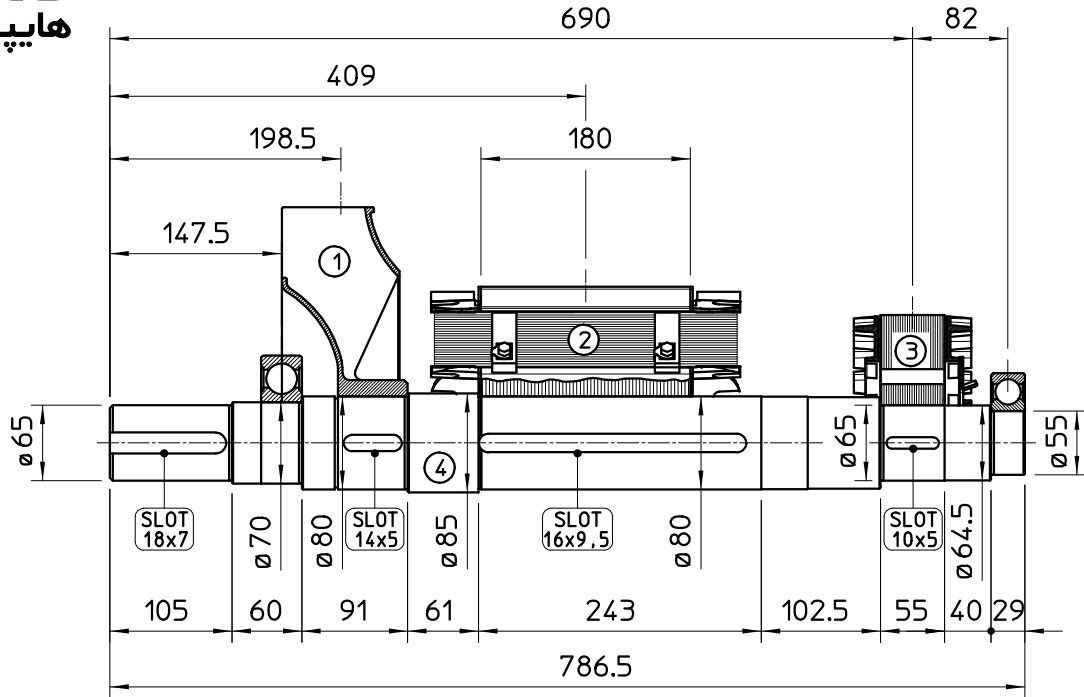

COMPONENT	WEIGHT kg	J kgm ²
1 FAN	3,3	0,0451
2 MAIN ROTOR	63	0,6144
3 EX. ROTOR	14,5	0,0874
4 SHAFT	26,6	0,0194
TOTAL	107,4	0,7663

FAMCO
هایپر صنعت

TWO BEARING DIMENSIONS

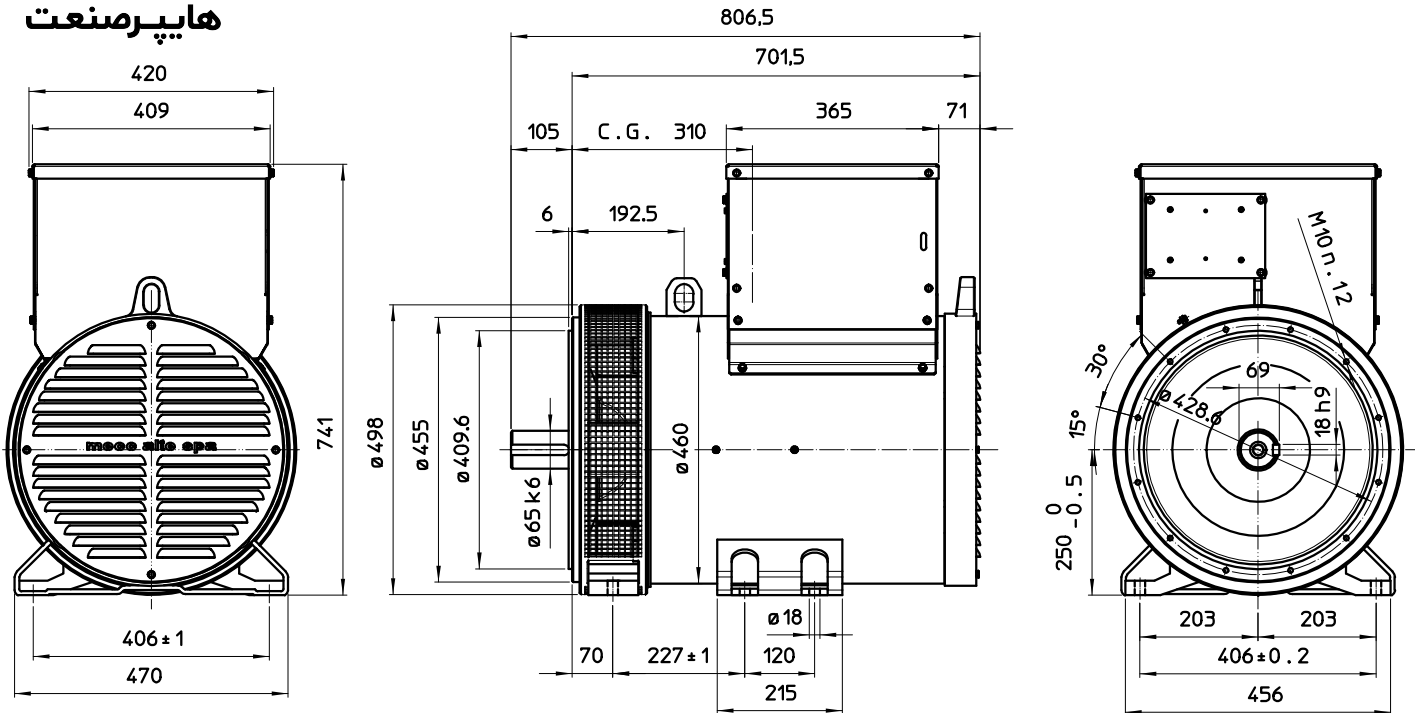

C.G.= GRAVITY CENTER

Electrical Characteristics										
Frequency	Hz	50				60				
Voltage (series star)	V	380	400	415	440	415	440	460	480	
Rated power class H	kVA	50	50	50	40	58	60	60	60	
	kW	40	40	40	32,0	46,4	48	48	48	
Rated power class F	kVA	48	48	48	38	56	58	58	58	
	kW	38,4	38,4	38,4	30,4	44,8	46,4	46,4	46,4	
Regulation with	SR7/2	±1,5 % with any power factor and speed variations between -5% +30%								
Insulation class		H								
Execution		Brushless								
Stator winding		12 ends								
Rotor		with damping cage								
Efficiencies class H	4/4	%	89	89,1	88,8	88,6	91,1	91,6	91,7	91,8
(see graph. for details)	3/4	%	89,2	89,5	89,4	89,1	91,5	91,7	91,9	92,1
	2/4	%	87,5	87,6	87,6	87,4	88,8	88,9	89	89,1
	1/4	%	85,5	85,3	85,1	84,6	85,4	85	85,5	85,4
Reactances (f. l.cl. F)	Xd	%	271,5	245	227,6	162,0	316,8	291,6	266,8	245
	Xd'	%	14,96	13,5	12,54	8,93	17,46	16,07	14,70	13,5
	Xd''	%	8,20	7,4	6,87	4,89	9,57	8,81	8,06	7,4
	Xq	%	113,0	102	94,8	67,4	131,9	121,4	111,1	102
	Xq'	%	113,0	102	94,8	67,4	131,9	121,4	111,1	102
	Xq''	%	34,9	31,5	29,3	20,8	40,7	37,5	34,3	31,5
	X ₂	%	23,27	21	19,51	13,88	27,16	24,99	22,87	21
	x ₀	%	3,21	2,9	2,69	1,92	3,75	3,45	3,16	2,9
Short Circuit Ratio	Kcc		0,62	0,71	0,73	1,30	0,40	0,48	0,62	0,71
Time Constants	Td'	sec.	0,059							
	Td''	sec.	0,013							
	Tdo'	sec.	1,40							
	Tα	sec.	0,035							
Short Circuit Current Capacity		%	>300				>350			
Excitation at no load	Amp.		0,6	0,7	0,8	1,2	0,3	0,4	0,5	0,6
Excitation at full load	Amp.		2,2	2,4	2,3	2,7	2,1	1,9	2,1	2,3
Overload (long-term)		%	1 hour in a 6 hours period 110% rated load							
Overload per 20 sec.		%	300							
Stator Winding Resistance (20°C)	Ω		0,061							
Rotor Winding Resistance (20°C)	Ω		2,473							
Exciter Resistance (20 °C)	Ω		Rotor : 0,442				Stator : 11,35			
Heat dissipation at f.l.cl.H	W		4944	4893	5045	4117	4533	4402	4345	4288
Telephone Interference			FHT < 2%				TIF < 45			
Radio interference			EN50081-1, EN50082-1, VDE0875K. For others standards apply to factory							
Waveform Distors.(THD) at f. load	LL/LN %		3,8 / 3,6							
Waveform Distors.(THD) at no load	LL/LN %		3,3 / 3,2							
Mechanical characteristics										
Protection			IP 21 (other protection on request)							
DE bearing			6312-2RS							
NDE bearing			6309-2RS							
Weight of wound stator assembly	kg		78							
Weight of wound rotor assembly	kg		53							
Weight of complete generator	kg		248							
Maximun overspeed	rpm		2250							
Unbalanced magnetic pull at f.l.cl.F	kN/mm		4,1							
Cooling air requirement	m ³ /min		11,8				14,5			
Inertia Constant (H)	sec.		0,105				0,125			
Noise level at 1m/7m	dB(A)		75 / 60				79 / 64			

This document is a propriety of Mecc Alte S.p.a..All rights reserved.

50 Hz

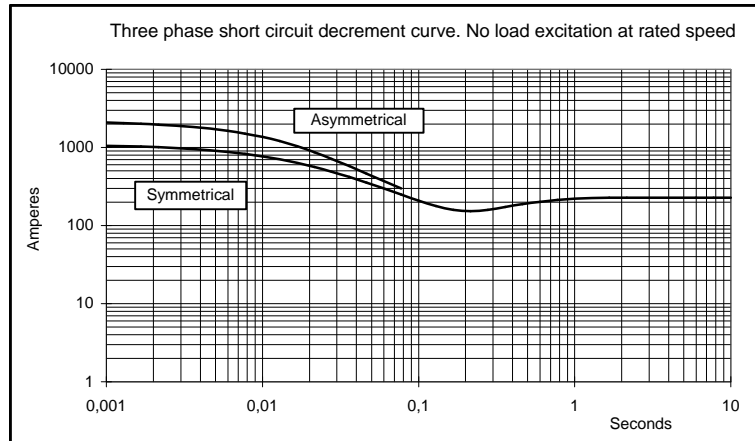
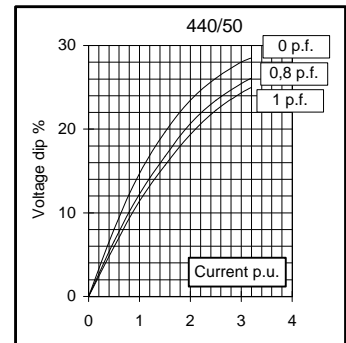
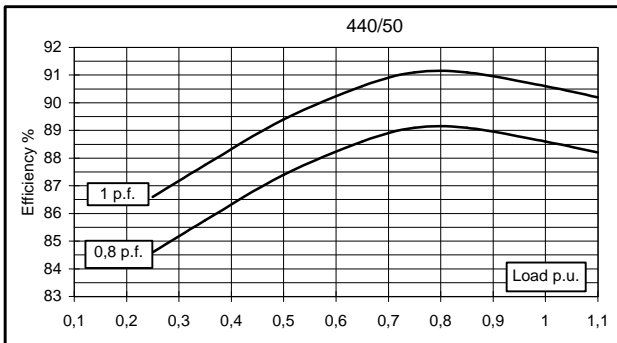
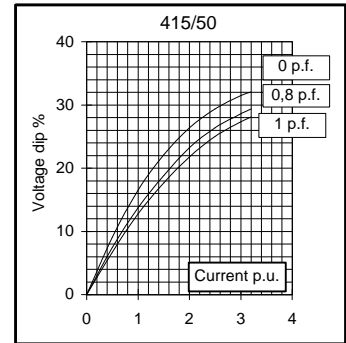
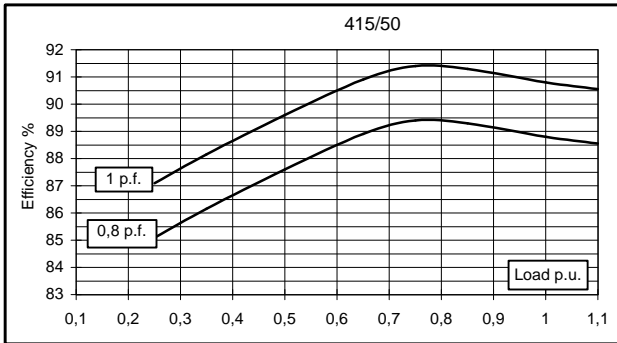
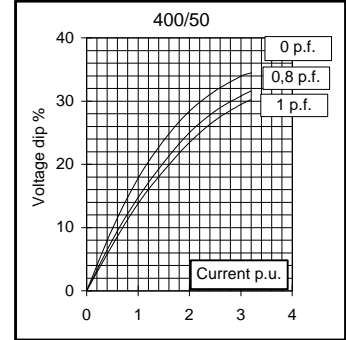
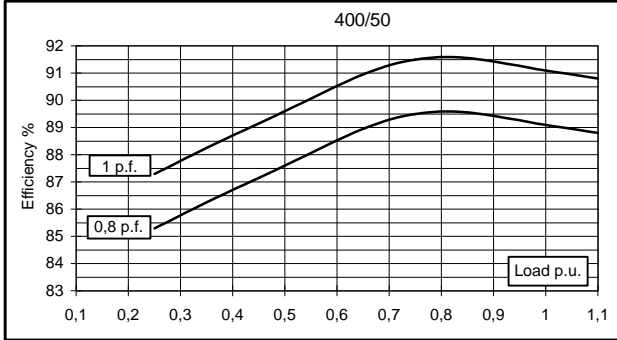
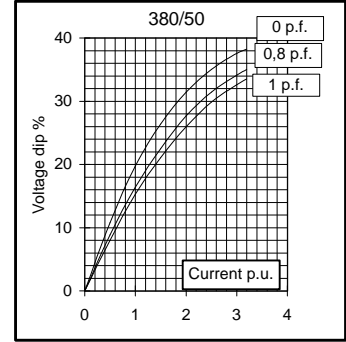
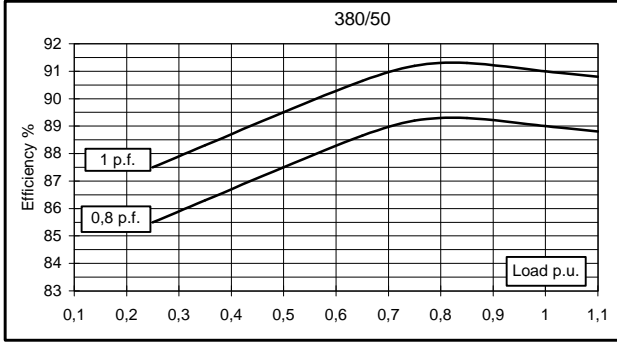

This document is a propriety of Mecc Alte S.p.a.. All rights reserved.

60 Hz

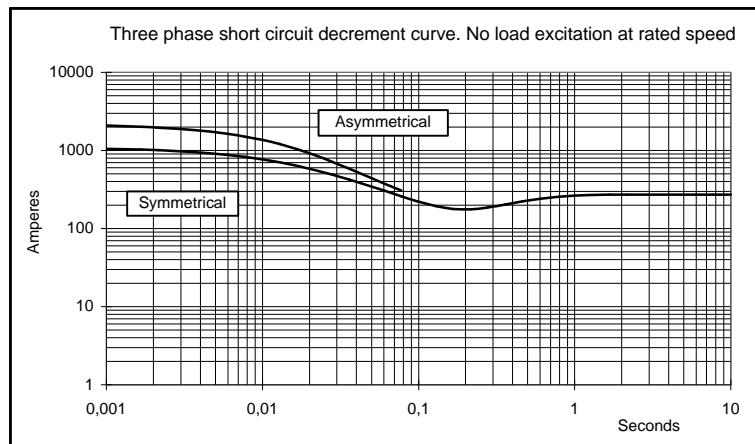
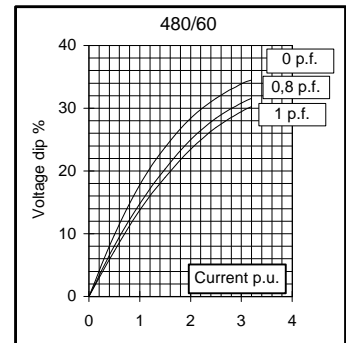
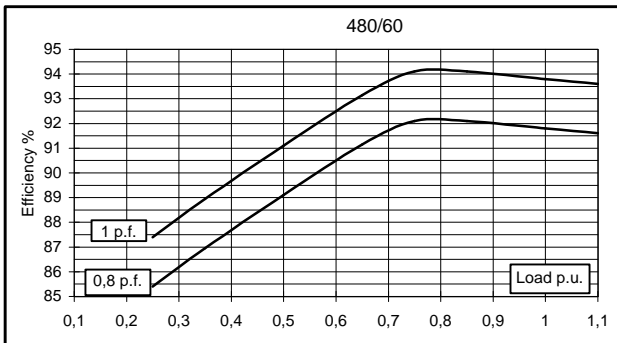
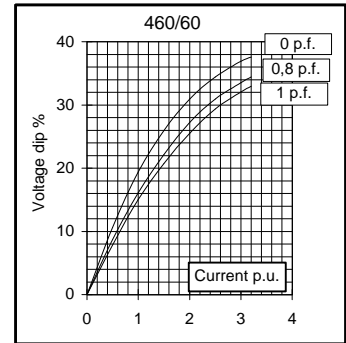
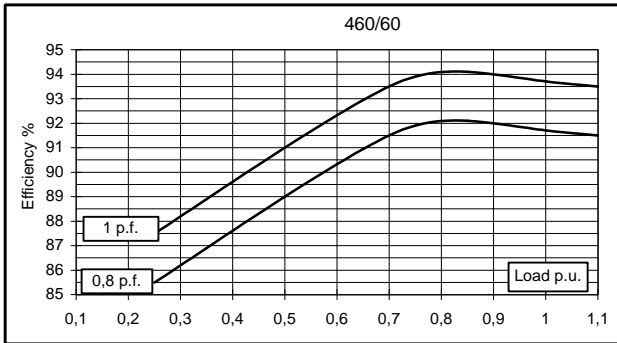
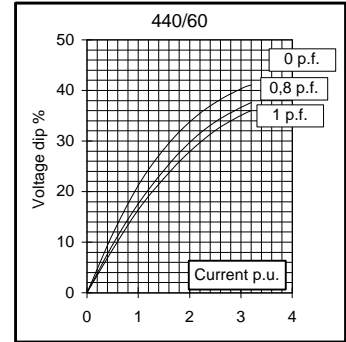
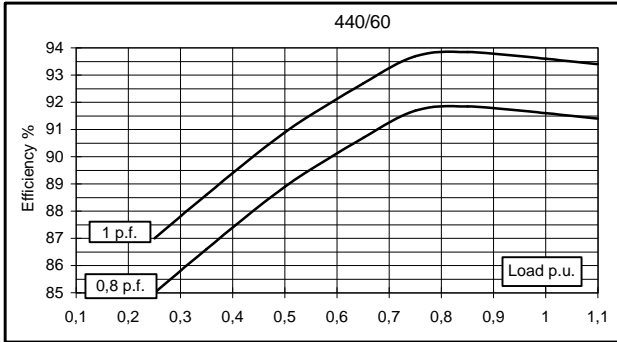
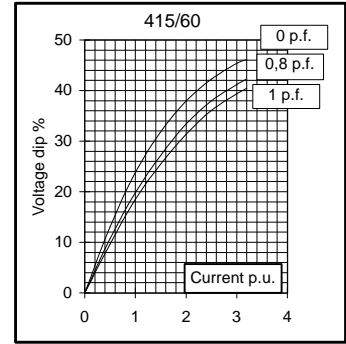
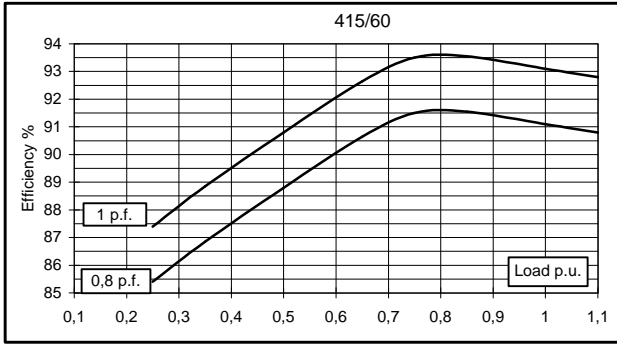

This document is a propriety of Mecc Alte S.p.a.. All rights reserved.

SINGLE BEARING MOMENTS OF INERTIA

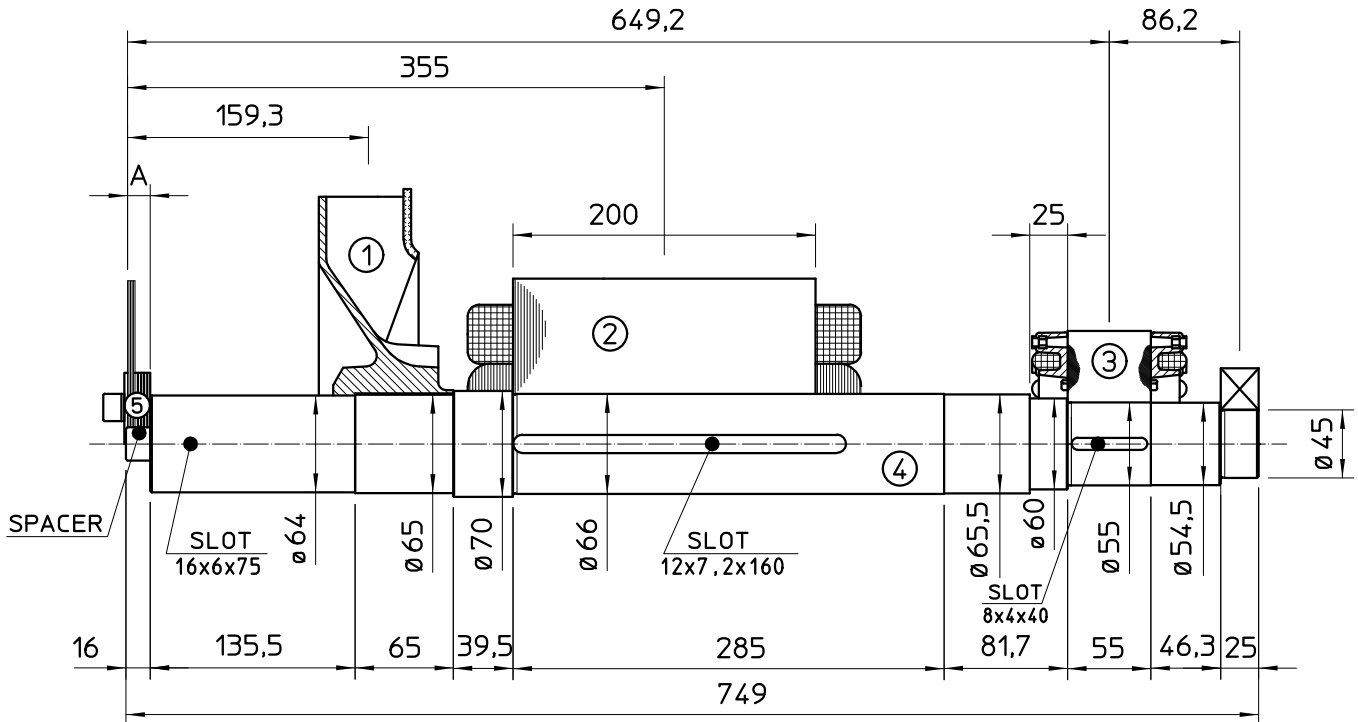

FAMCO
هایپر صنعت

COMPONENT	WEIGHT kg	J kgm ²
1 FAN	2,3	0,0224
2 MAIN ROTOR	53	0,3763
3 EX. ROTOR	7	0,016
4 SHAFT	18,3	0,0094
TOTAL	80,6	0,4241

SAE No	SHAFTS COUPLING FLEX PLATE			
	A (mm)	WEIGHT kg	J kgm ²	
6,5	5	1,74	0,0084	
7,5	5	2,1	0,013	
8	36,6	3,9	0,02	
10	28,6	4,47	0,038	
11,5	15	4,51	0,059	

SINGLE BEARING DIMENSIONS

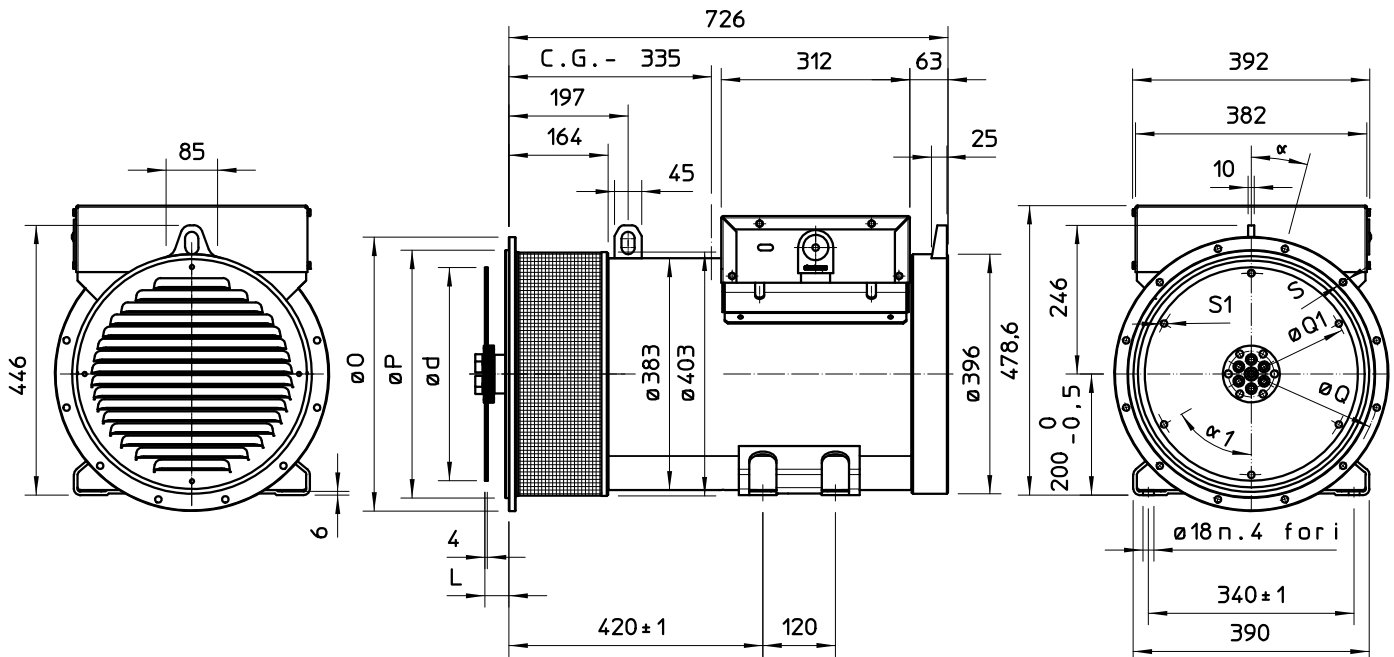

FAMCO
هایپر صنعت

SAE No	DISC COUPLING					
	L	d	Q1	No holes	S1	a1
6,5	30,2	215,9	200	6	9	60°
7,5	30,2	241,3	222,25	8	9	45°
8	62	263,52	244,47	6	11	60°
10	53,8	314,32	295,27	8	11	45°
11,5	39,6	352,42	333,37	8	11	45°

SAE No	FLANGE					
	O	P	Q	No holes	S	a
5	356	314,3	333,4	8	11	22°30'
4	403	362	381	12	11	15°
3	451	409,6	428,6	12	11	15°
2	489	447,7	466,7	12	11	15°
1	552	511,2	530,2	12	11	15°

C.G. = GRAVITY CENTER

Electrical Characteristics										
Frequency	Hz	50				60				
Voltage (series star)	V	380	400	415	440	415	440	460	480	
Rated power class H	kVA	200	200	200	190	230	240	240	240	
	kW	160	160	160	152	184	192	192	192	
Rated power class F	kVA	185	185	185	175	210	220	220	220	
	kW	148	148	148	140	168	176	176	176	
Regulation with DSR		±1 % with any power factor and speed variations between -5% +30%								
Insulation class		H								
Execution		Brushless								
Stator winding		12 ends								
Rotor		with damping cage								
Efficiencies class H	4/4	%	92,6	92,7	92,4	92,2	93,1	93,6	93,7	93,8
(see graph. for details)	3/4	%	92,6	92,9	92,8	92,5	93,4	93,6	93,8	94
	2/4	%	91,6	91,7	91,7	91,5	92,5	92,6	92,7	92,8
	1/4	%	90,1	89,9	89,7	89,5	90,6	90,6	90,6	90,4
Reactances (f. l.cl. F)	Xd	%	221,6	200	185,8	157,0	256,4	238,0	217,8	200
	Xd'	%	12,2	11,0	10,2	8,6	14,1	13,1	12,0	11,0
	Xd''	%	6,5	5,9	5,5	4,6	7,6	7,0	6,4	5,9
	Xq	%	121,9	110	102,2	86,4	141,0	130,9	119,8	110
	Xq'	%	121,9	110	102,2	86,4	141,0	130,9	119,8	110
	Xq''	%	23,8	21,5	20,0	16,9	27,6	25,6	23,4	21,5
	X ₂	%	15,8	14,3	13,3	11,2	18,3	17,0	15,6	14,3
	X ₀	%	2,8	2,5	2,3	2,0	3,2	3,0	2,7	2,5
Short Circuit Ratio	Kcc		0,43	0,46	0,64	1,02	0,32	0,39	0,43	0,46
Time Constants	Td'	sec.	0,078							
	Td''	sec.	0,012							
	Tdo'	sec.	0,90							
	Tα	sec.	0,016							
Short Circuit Current Capacity		%	>300				>350			
Excitation at no load	Amp.		0,5	0,7	0,9	1,2	0,3	0,35	0,45	0,65
Excitation at full load	Amp.		2,9	3	3,2	3,4	2,4	2,6	2,8	2,9
Overload (long-term)		%	1 hour in a 6 hours period 110% rated load							
Overload per 20 sec.		%	300							
Stator Winding Resistance (20 °C)		Ω	0,0105							
Rotor Winding Resistance (20 °C)		Ω	4,133							
Exciter Resistance (20 °C)		Ω	Rotor : 0,685				Stator : 15,28			
Heat dissipation at f.l.cl.H	W		12786	12600	13160	12859	13637	13128	12909	12691
Telephone Interference			THF < 2%				TIF < 40			
Radio interference			EN61000-6-3, EN61000-6-2. For others standards apply to factory							
Waveform Distors.(THD) at f. load	LL/LN %		2,7 / 2,6							
Waveform Distors.(THD) at no load	LL/LN %		3 / 2,9							
Mechanical characteristics										
Protection			IP 21 (other protection on request)							
DE bearing			6318.2RS							
NDE bearing			6314.2RS							
Weight of wound stator assembly	kg		174							
Weight of wound rotor assembly	kg		113							
Weight of complete generator	kg		560							
Maximun overspeed	rpm		2250							
Unbalanced magnetic pull at f.l.cl.F	kN/mm		5,2							
Cooling air requirement	m ³ /min		32				39			
Inertia Constant (H)	sec.		0,116				0,140			
Noise level at 1m/7m	dB(A)		82 / 69				86 / 73			

50 Hz

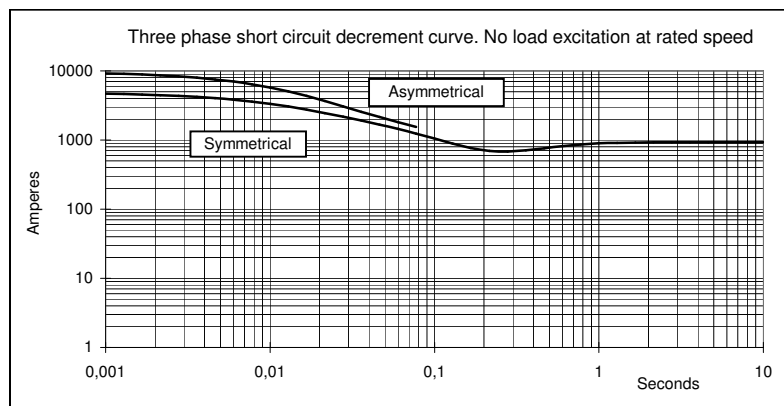
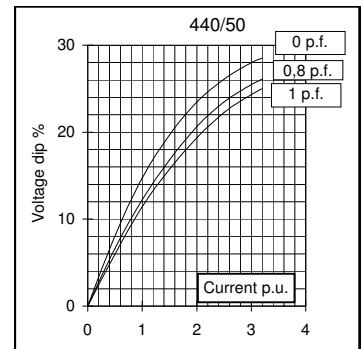
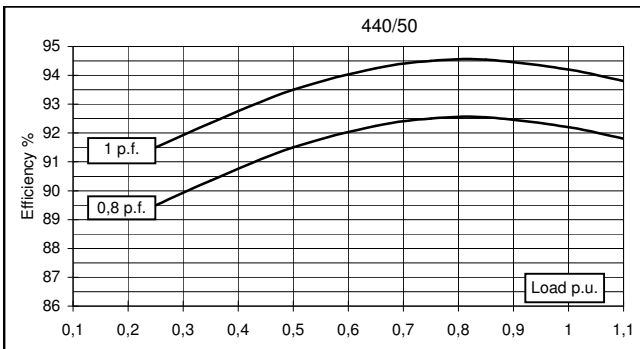
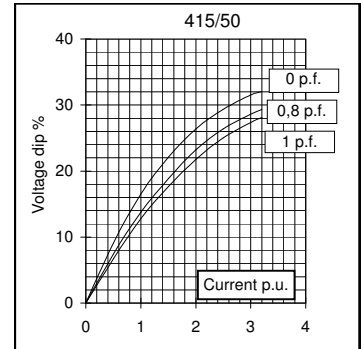
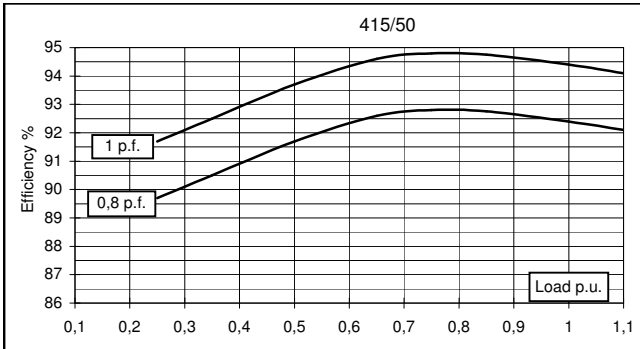
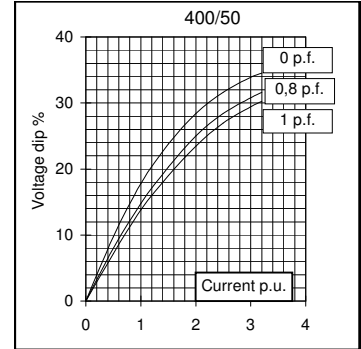
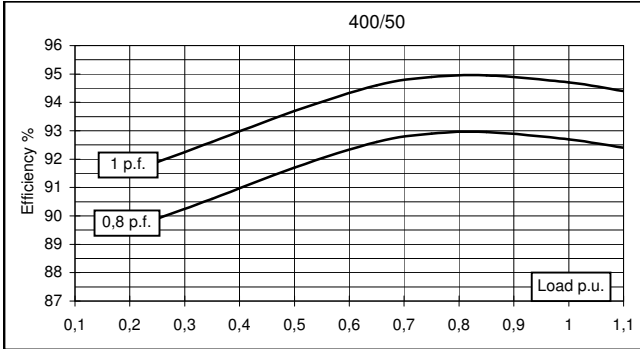
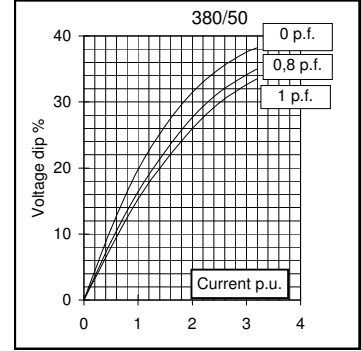
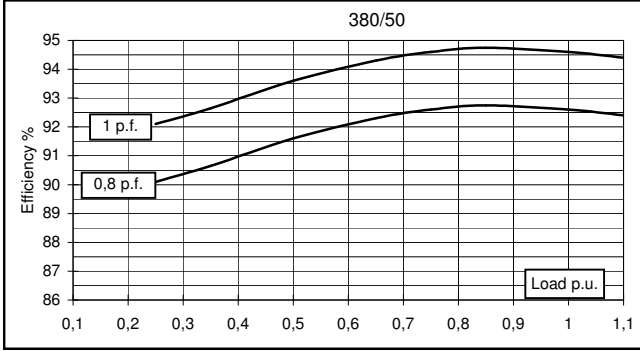

This document is a propriety of Mecc Alte S.p.a.. All rights reserved.

60 Hz

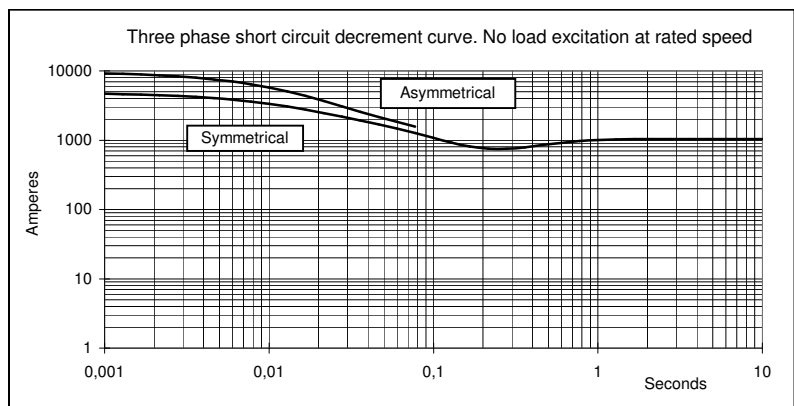
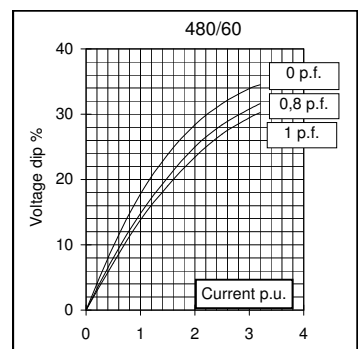
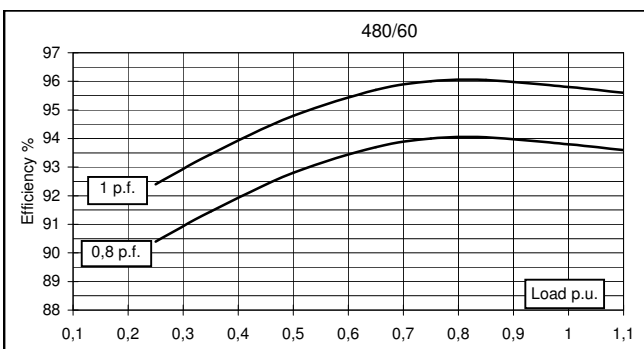
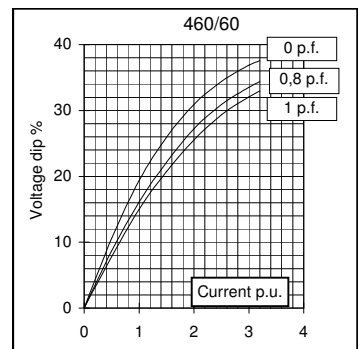
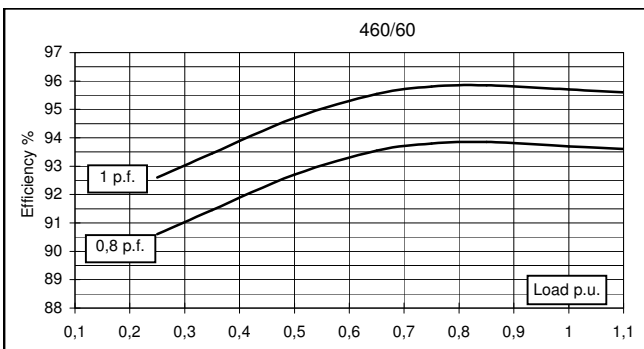
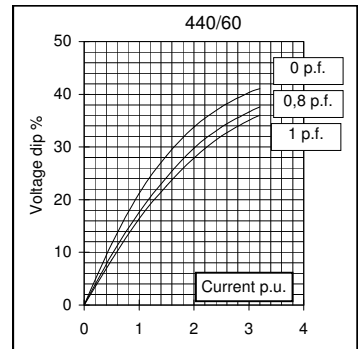
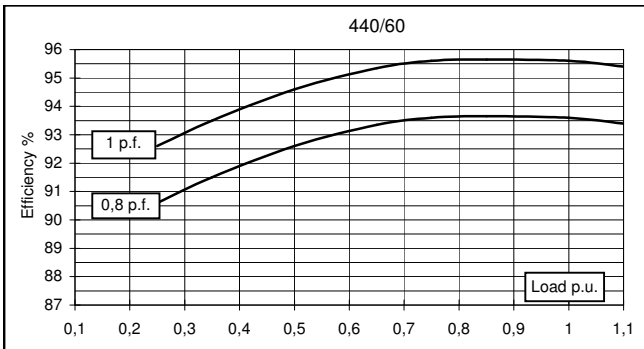
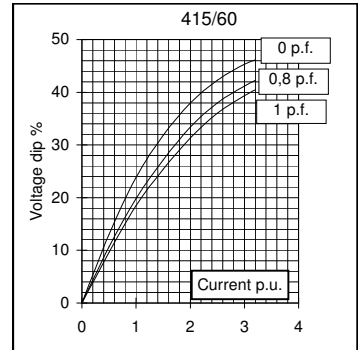
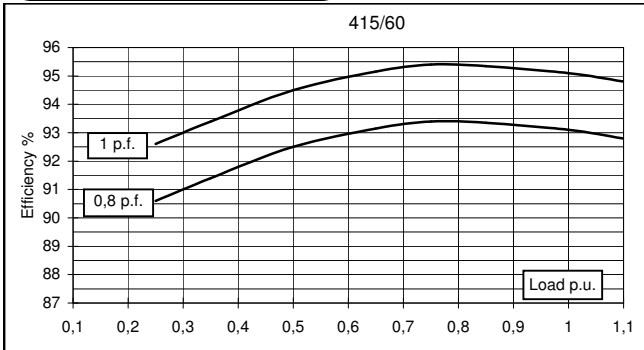

This document is a propriety of Mecc Alte S.p.a.. All rights reserved.

TWO BEARING MOMENTS OF INERTIA

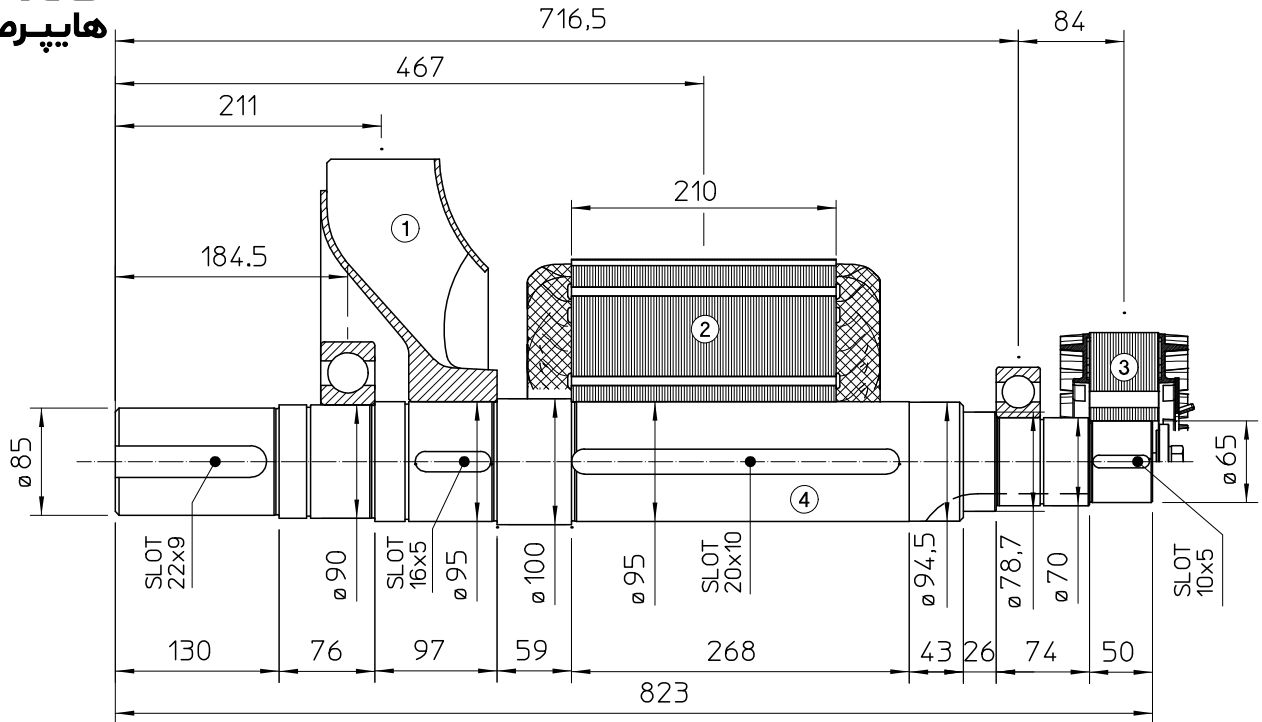

POS.	COMPONENT	WEIGHT (kg)	J (kgm ²)
1	FAN	6.1	0.1887
2	MAIN ROTOR	113	1.5641
3	EX. ROTOR	14.5	0.0874
4	SHAFT	38.5	0.0397
TOTAL		172.1	1.8799

TWO BEARING DIMENSIONS

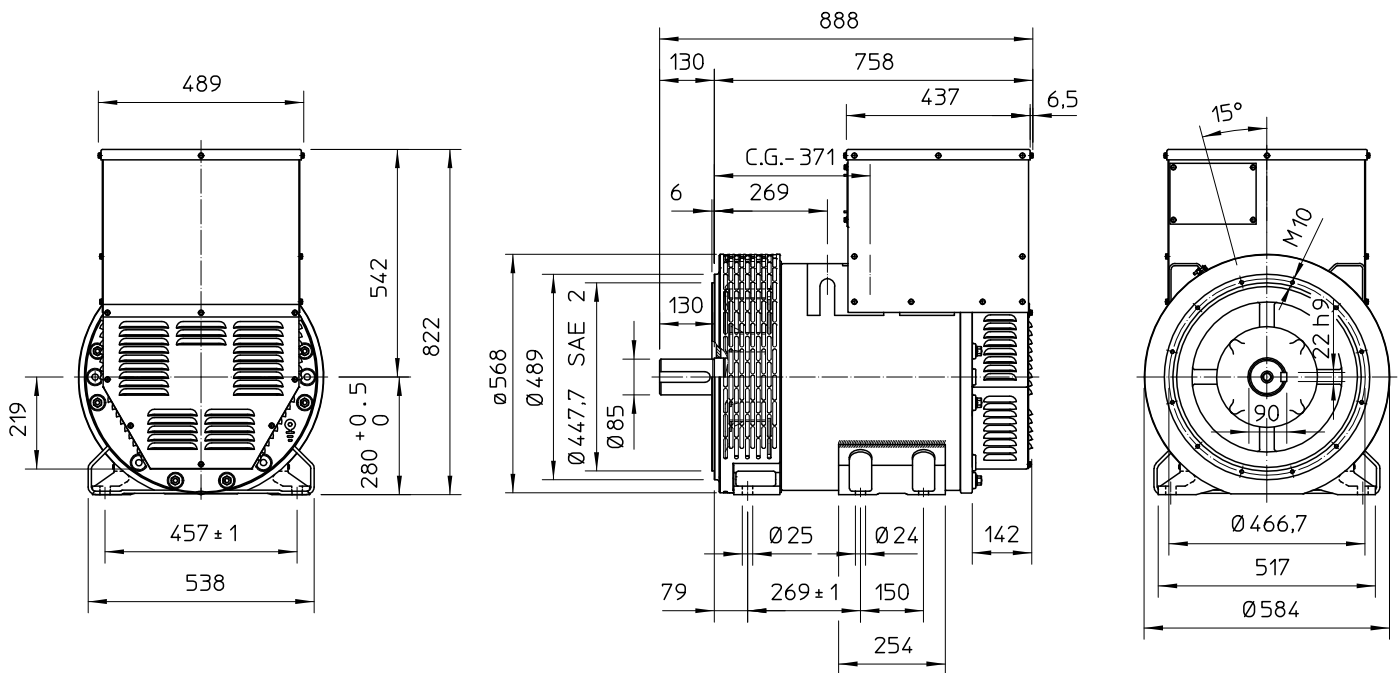

FAMCO
 هایپر صنعت

SINGLE BEARING MOMENTS OF INERTIA

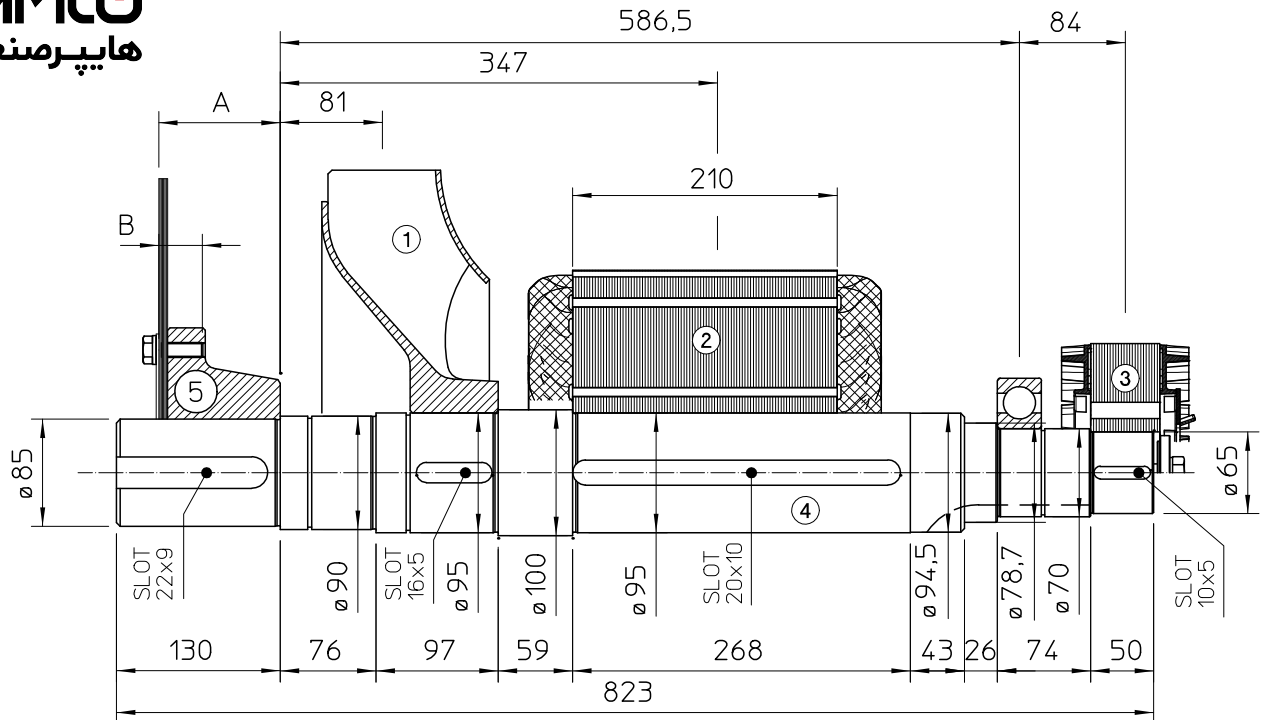

POS.	COMPONENT	WEIGHT (kg)	J (kgm ²)
1	FAN	6.1	0.1887
2	MAIN ROTOR	113	1.5641
3	EX. ROTOR	14.5	0.0874
4	SHAFT	38.5	0.0397
TOTAL		172.1	1.8799

SAE N°	5		SHAFTS COUPLING FLEX PLATE	
	A	B	WEIGHT kg	J kgm ²
11.5	110.4	41.1	20.5	0.174
14	96.4	34.7	23.5	0.275

FAMCO
 هایپر صنعت

SINGLE BEARING DIMENSIONS

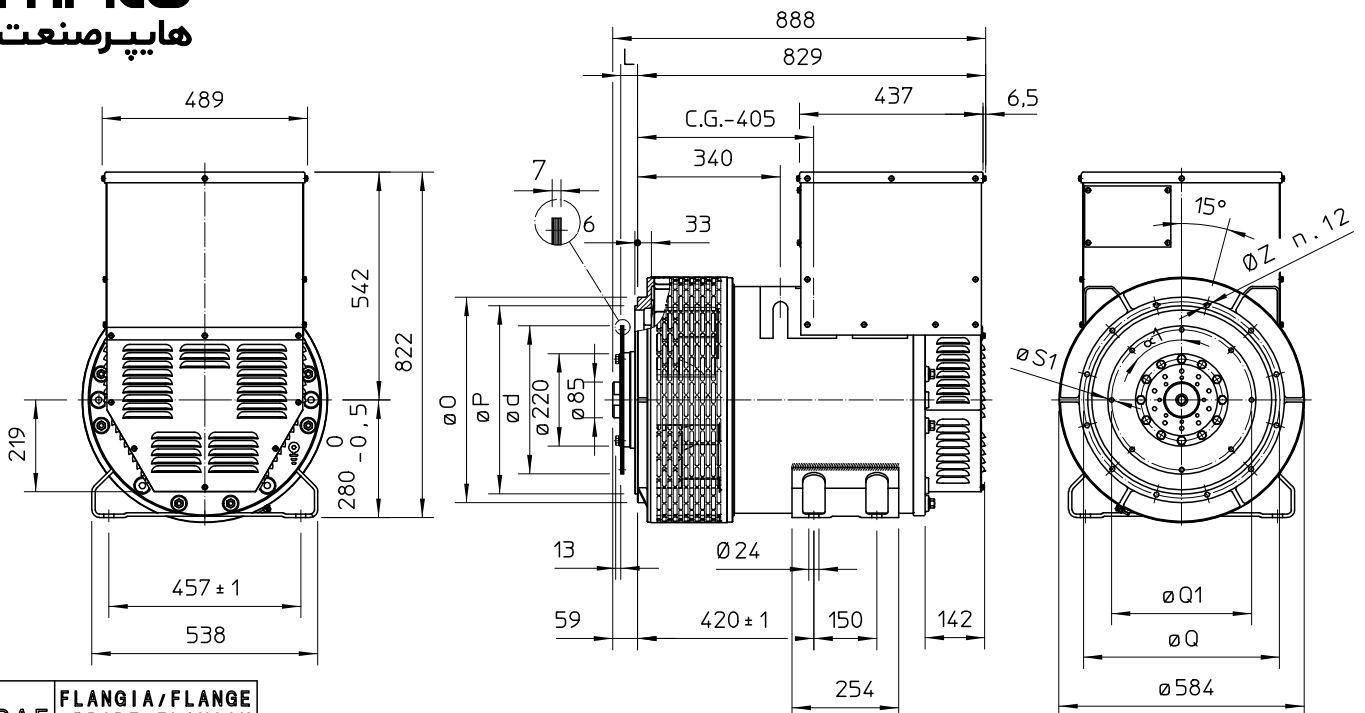

SAE N.	FLANGIA/FLANGE BRIDE/FLANSCH		
	O	P	Q
3	451	409,6	428,6
2	489	447,7	466,7
1	552	511,2	530,2
1/2	648	584,2	619,1

SAE N.	GIUNTI A DISCHI DISC COUPLING DISQUE DE MONOPALIER SCHEIBENKUPPLUNG				
	L	d	Q1	n _{fori}	S1
11 1/2	39,6	352,42	333,37	8	11 45°
14	25,4	466,72	438,15	8	14 45°

C.G.= GRAVITY CENTER

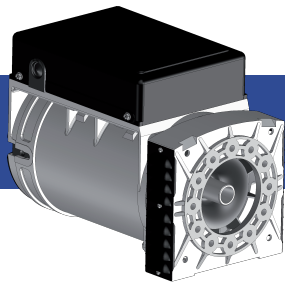

S16F

MECCALTE spa - Via Roma, 20 - 36051 CREAZZO (VI) ITALY
Tel. +39 0444/396111 - Fax +39 0444/396166 - e-mail: info@meccalte.it
website: www.meccalte.com

2 POLE
1 PHASE
IP23

CHARACTERISTICS

50 Hz

Type	115/230V 50Hz 3000 RPM									
	kVA	η	η	η	T.H.D.	Air volume	Noise		Weight	J
		2/4 1 p.f.	3/4 1 p.f.	4/4 1 p.f.			7m dBA	1m dBA		
CL. H	%	%	%	%	m ³ /min			Kg	Kgm ²	
S16F -150	5,5	76,4	79,2	79	< 6	3,4	60	78	28	0,0105
S16F -180	6,5	76,8	79,7	79,5	< 6	3,4	60	78	31	0,0174

60 Hz

Type	120/240V 60Hz 3600 RPM									
	kVA	η	η	η	T.H.D.	Air volume	Noise		Weight	J
		2/4 1 p.f.	3/4 1 p.f.	4/4 1 p.f.			7m dBA	1m dBA		
CL. H	%	%	%	%	m ³ /min			Kg	Kgm ²	
S16F -150	6,6	76,8	79,7	79,6	< 6	4,3	62	80	28	0,0105
S16F -180	7,8	77,1	80,3	80,1	< 6	4,3	62	80	31	0,0174

OVERALL DIMENSIONS



dimensions in mm.

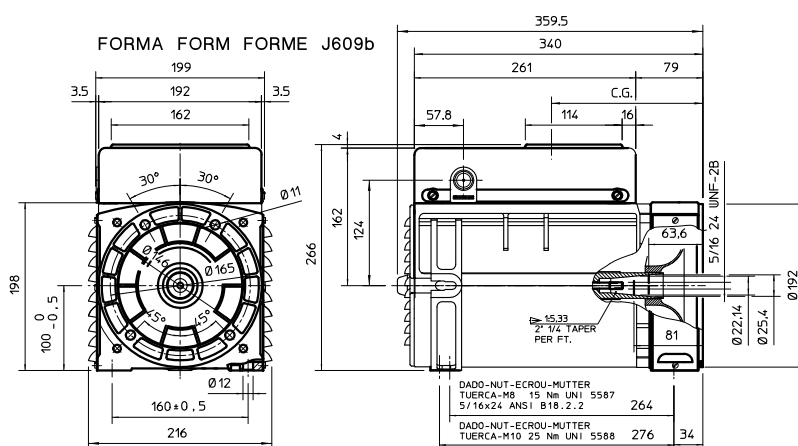
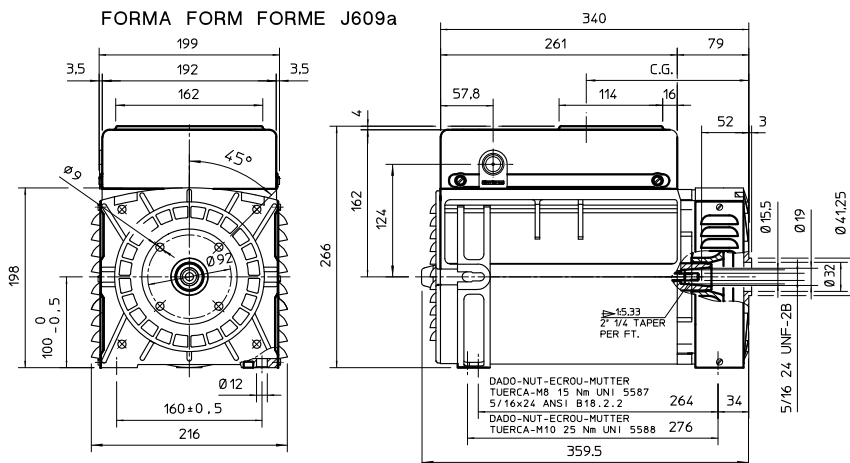
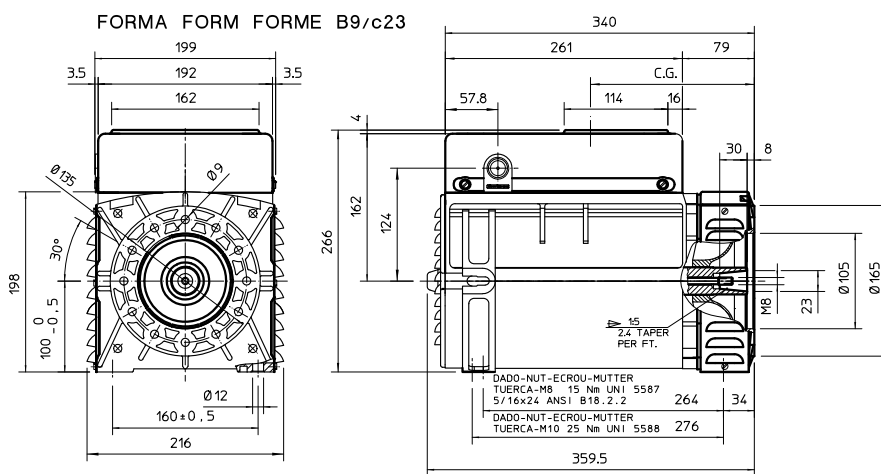
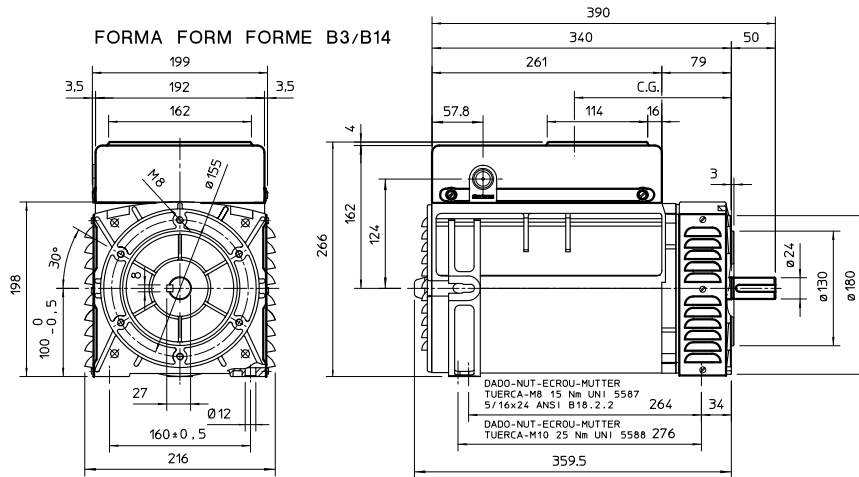

FORM	CG	
	150	180
B14	178	163
B9	180	165
J609a	179	164
J609b	179	164

Electrical Characteristics										
Frequency	Hz	50				60				
Voltage (series star)	V	380	400	415	440	415	440	460	480	
Rated power class H	kVA	105	105	105	85	115	126	126	126	
	kW	84	84	84	68	92	101	101	101	
Rated power class F	kVA	95	95	95	77	104	114	114	114	
	kW	76	76	76	61,6	83,2	91,2	91,2	91,2	
Regulation with DSR		±1% with any power factor and speed variations between -5% +30%								
Insulation class		H								
Execution		Brushless								
Stator winding		12 ends								
Rotor		with damping cage								
Efficiencies class H	4/4	%	92,1	92,2	91,9	91,7	93,1	93,6	93,7	93,8
(see graph. for details)	3/4	%	92,2	92,5	92,4	92,1	93,6	93,8	93,9	94,1
	2/4	%	90,6	90,7	90,7	90,5	92	92,1	92,2	92,3
	1/4	%	87,2	87	86,8	86,8	88,2	88,2	88,2	88
Reactances (f. l.cl. F)	Xd	%	254,8	230	213,7	153,9	280,8	273,7	250,4	230
	Xd'	%	19,5	17,6	16,4	11,8	21,5	20,9	19,2	17,6
	Xd''	%	6,3	5,7	5,3	3,8	7,0	6,8	6,2	5,7
	Xq	%	165,8	149,6	139,0	100,1	182,7	178,0	162,9	149,6
	Xq'	%	165,8	149,6	139,0	100,1	182,7	178,0	162,9	149,6
	Xq''	%	34,6	31,2	29,0	20,9	38,1	37,1	34,0	31,2
	X ₂	%	20,5	18,5	17,2	12,4	22,6	22,0	20,1	18,5
	X ₀	%	3,9	3,5	3,3	2,3	4,3	4,2	3,8	3,5
Short Circuit Ratio	Kcc		0,41	0,47	0,61	0,90	0,32	0,35	0,41	0,47
Time Constants	Td'	sec.	0,0393							
	Td''	sec.	0,0055							
	Tdo'	sec.	1,70							
	Tα	sec.	0,0146							
Short Circuit Current Capacity		%	>300				>350			
Excitation at no load	Amp.		0,5	0,6	0,8	1,1	0,2	0,3	0,4	0,5
Excitation at full load	Amp.		2	2,2	2,3	2,6	1,7	1,9	2	2,2
Overload (long-term)		%	1 hour in a 6 hours period 110% rated load							
Overload per 20 sec.		%	300							
Stator Winding Resistance (20 °C)	Ω		0,02							
Rotor Winding Resistance (20 °C)	Ω		2,951							
Exciter Resistance (20 °C)	Ω		Rotor : 0,410				Stator : 15,28			
Heat dissipation at f.l.cl.H	W		7205	7106	7404	6155	6818	6892	6777	6663
Telephone Interference			THF < 2%				TIF < 40			
Radio interference			EN61000-6-3, EN61000-6-2. For others standards apply to factory							
Waveform Distors.(THD) at f. load	LL/LN %		1,8 / 1,9							
Waveform Distors.(THD) at no load	LL/LN %		2,8 / 2,9							
Mechanical characteristics										
Protection			IP 21 (other protection on request)							
DE bearing			6314.2RS							
NDE bearing			6311.2RS							
Weight of wound stator assembly	kg		126							
Weight of wound rotor assembly	kg		81							
Weight of complete generator	kg		409							
Maximun overspeed	rpm		2250							
Unbalanced magnetic pull at f.l.cl.F	kN/mm		5,1							
Cooling air requirement	m ³ /min		19,3				23			
Inertia Constant (H)	sec.		0,111				0,133			
Noise level at 1m/7m	dB(A)		79 / 65				83 / 69			

50 Hz

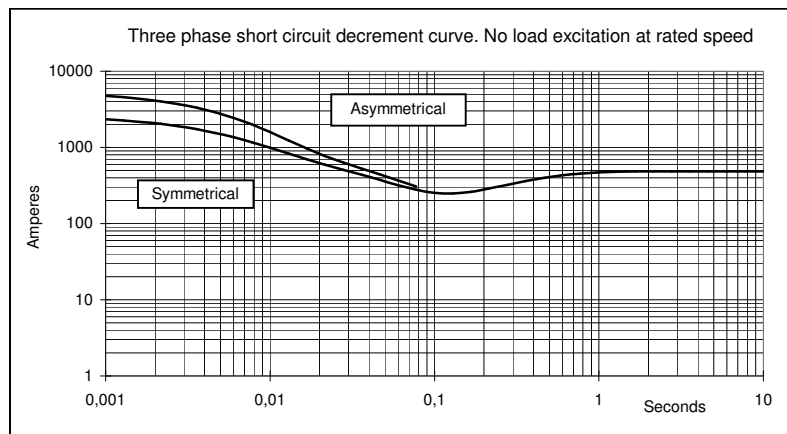
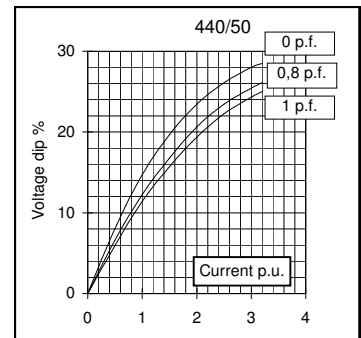
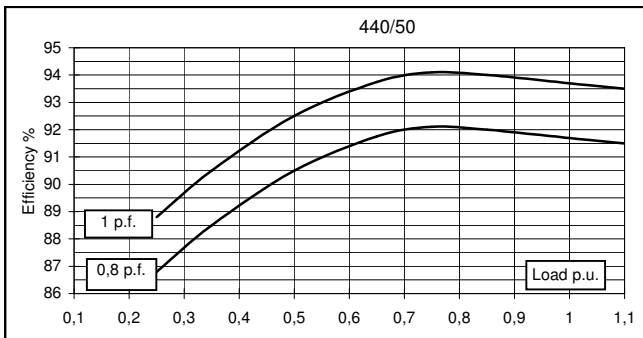
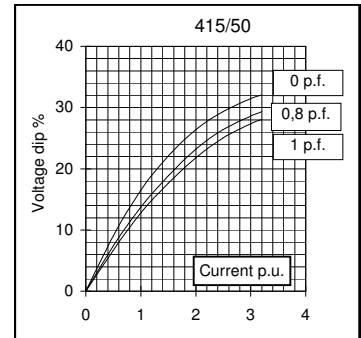
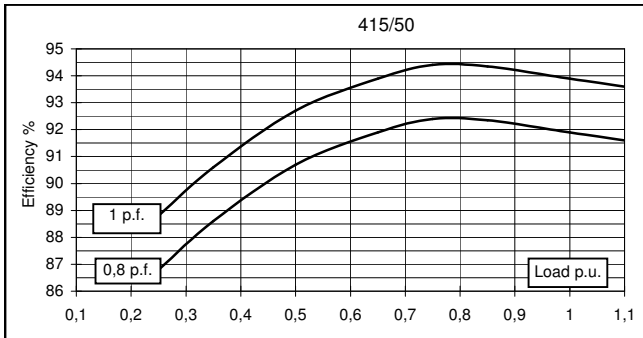
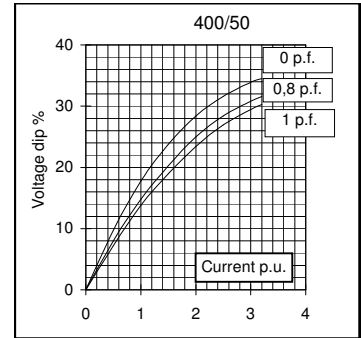
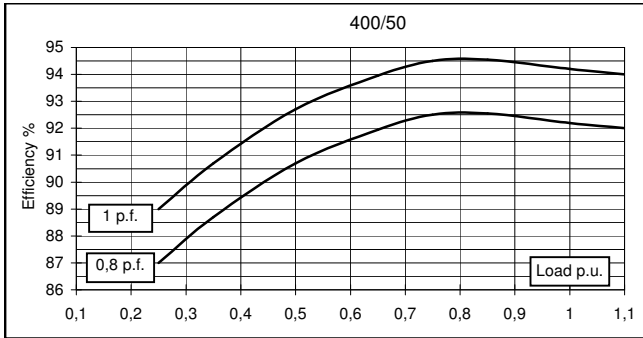
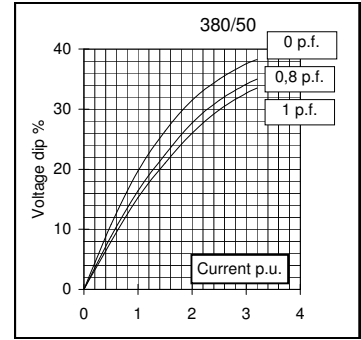
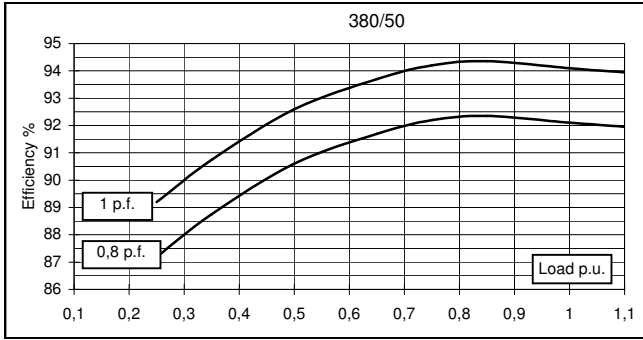

This document is a propriety of Mecc Alte S.p.a.. All rights reserved.

60 Hz

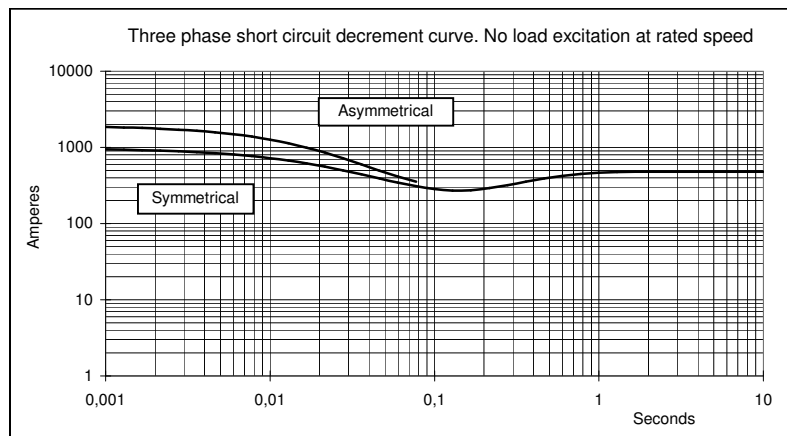
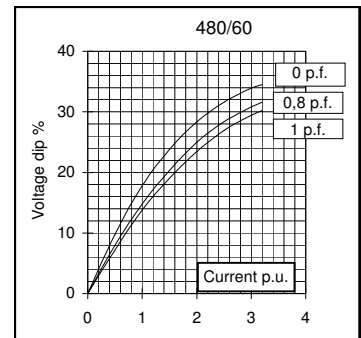
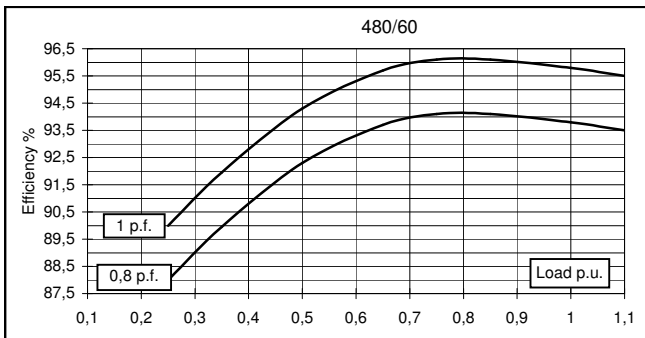
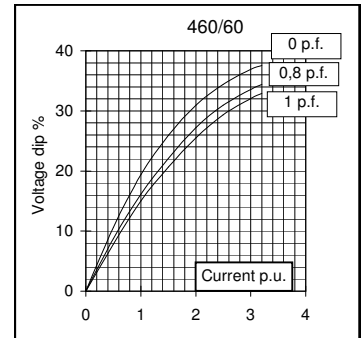
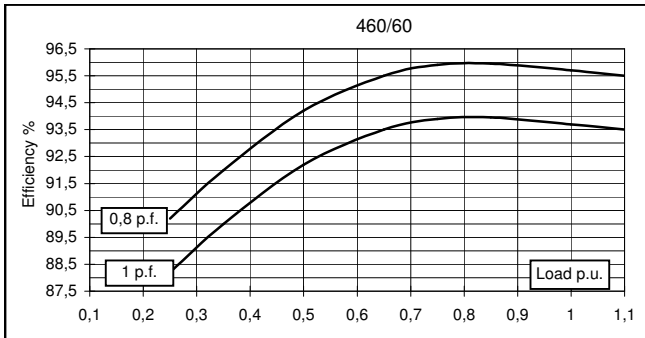
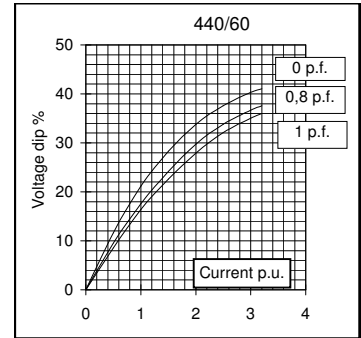
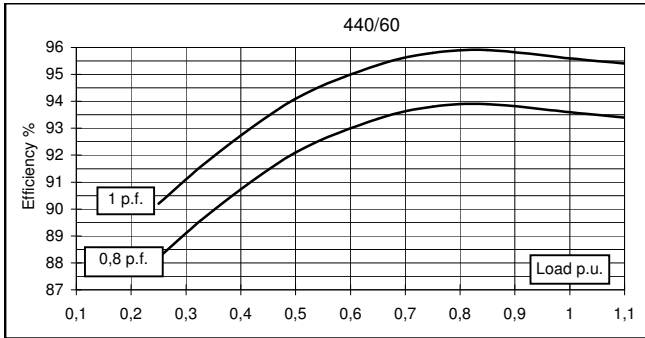
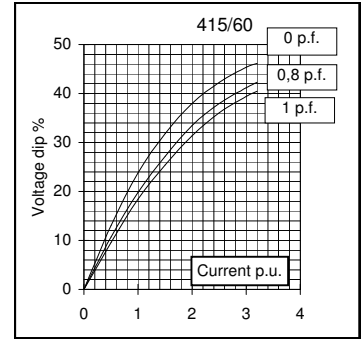
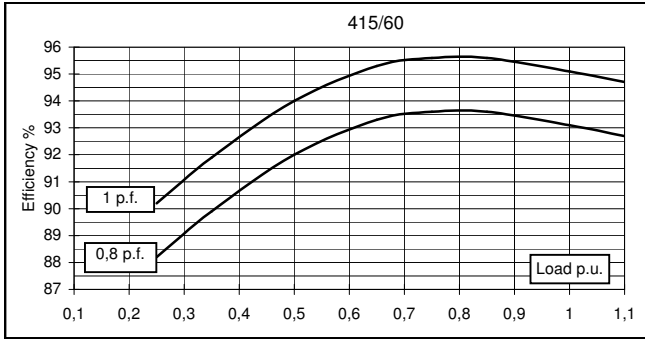

This document is a propriety of Mecc Alte S.p.a.. All rights reserved.

TWO BEARING MOMENTS OF INERTIA

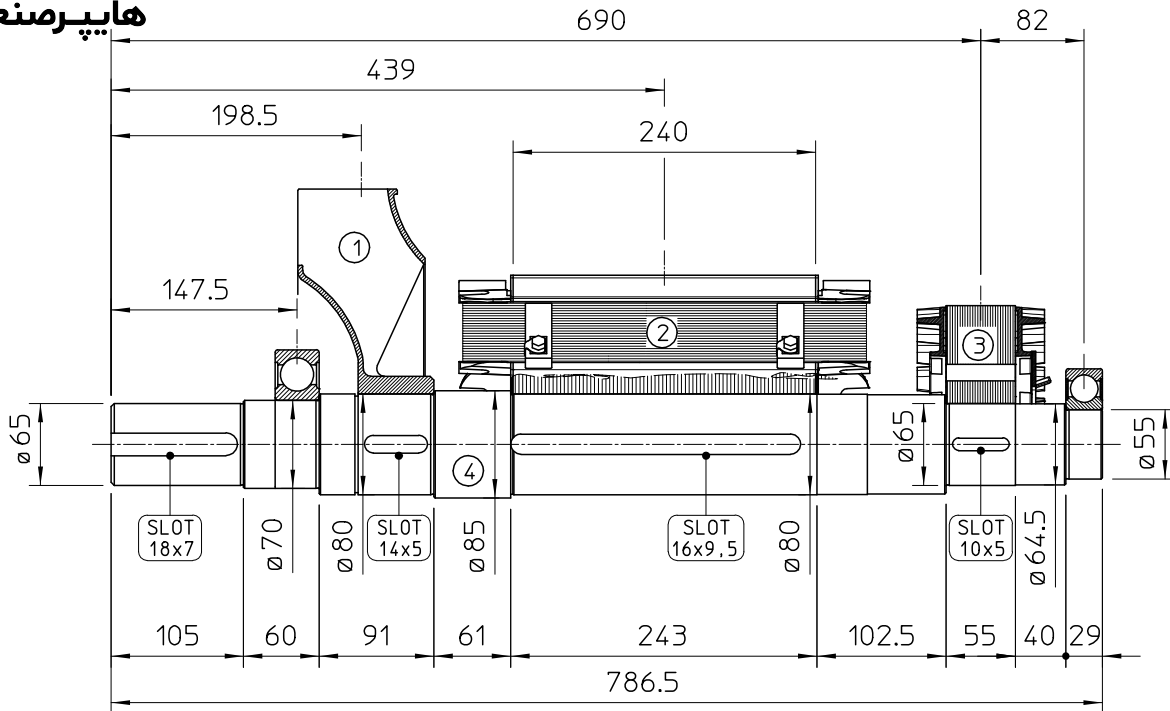

POS.	COMPONENT	WEIGHT (kg)	J (kgm ²)
1	FAN	3.6	0.0451
2	MAIN ROTOR	83.7	0.7539
3	EX. ROTOR	14.5	0.0874
4	SHAFT	26.8	0.0196
TOTAL		128.6	0.906

TWO BEARING DIMENSIONS

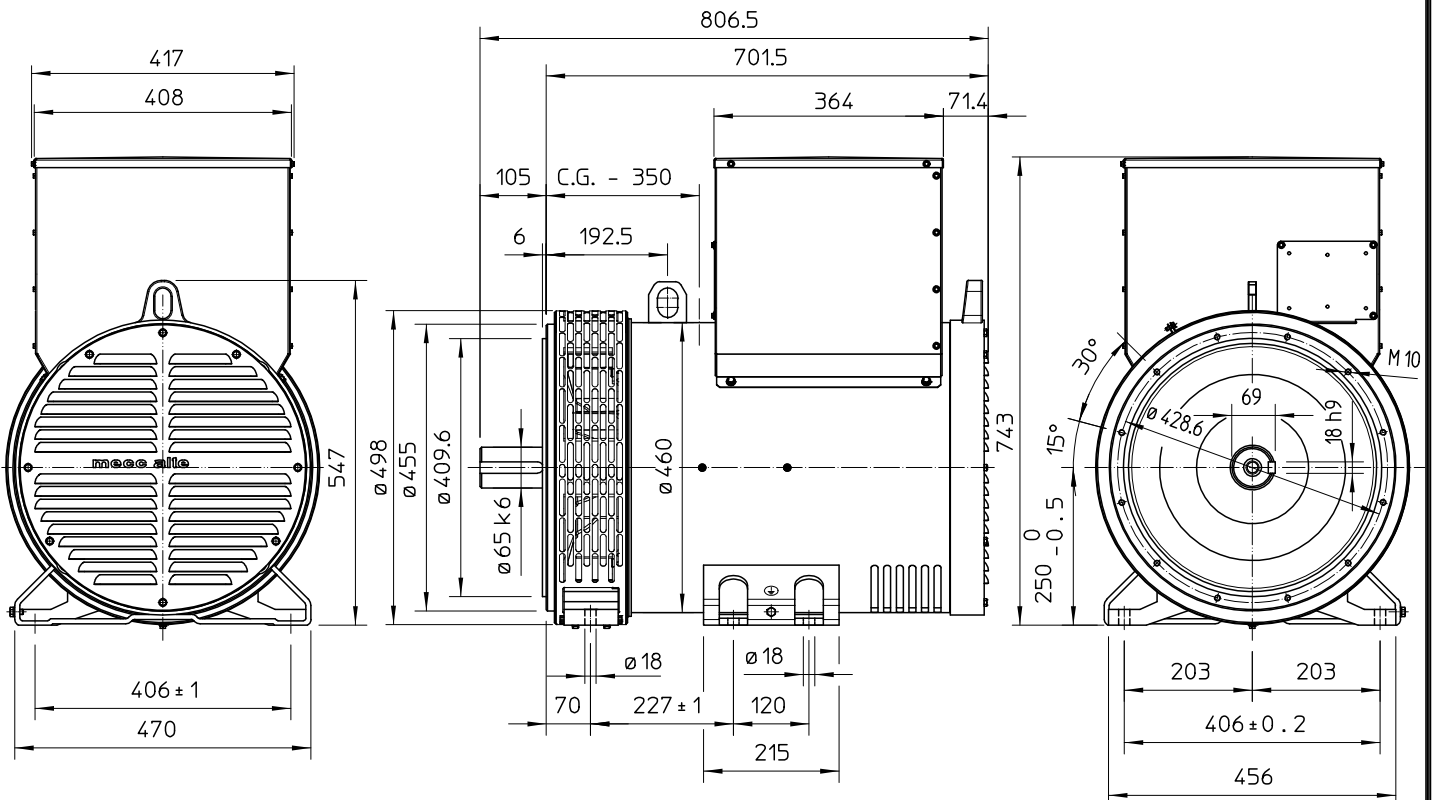

FAMCO
 هایپر صنعت

SINGLE BEARING MOMENTS OF INERTIA

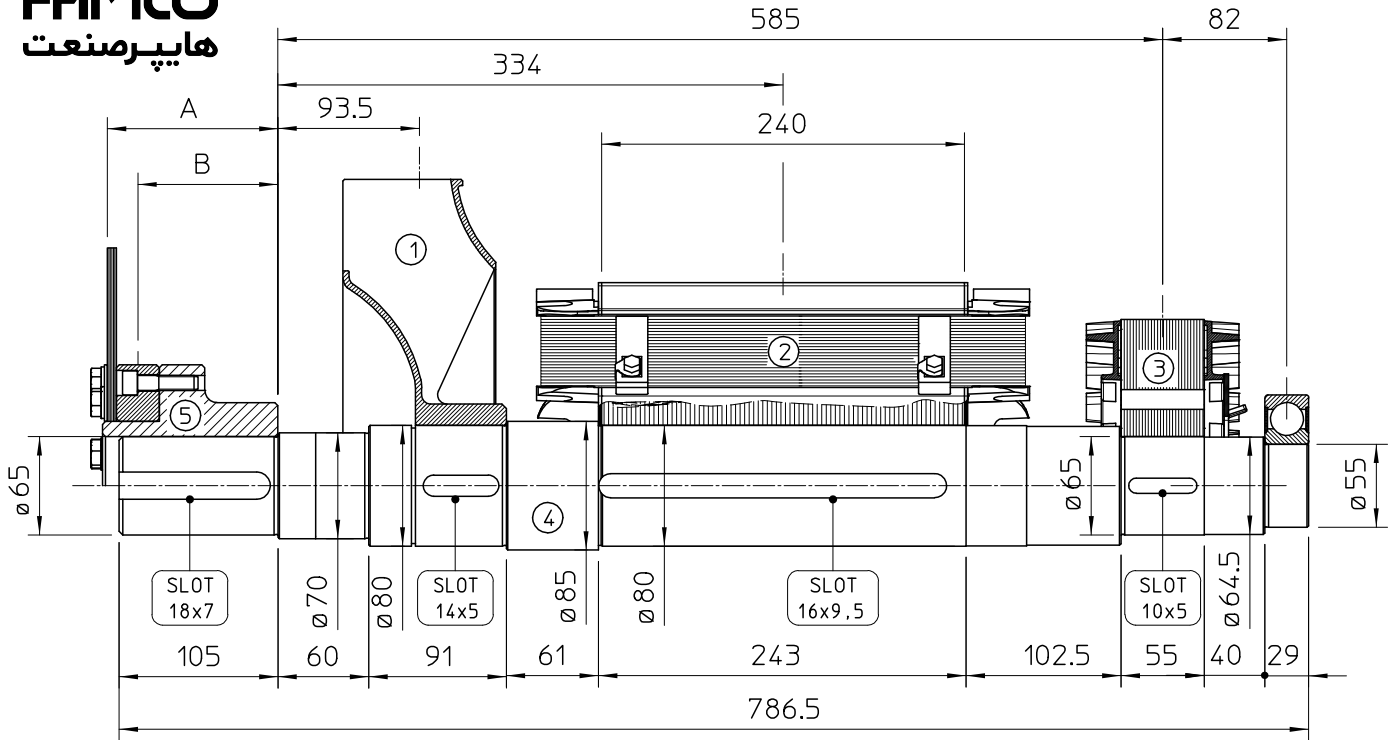

POS.	COMPONENT	WEIGHT (kg)	J (kgm ²)
1	FAN	3.6	0.0451
2	MAIN ROTOR	83.7	0.7539
3	EX. ROTOR	14.5	0.0874
4	SHAFT	26.8	0.0196
TOTAL		128.6	0.906

SAE N°	5		SHAFTS COUPLING FLEX PLATE	
	A	B	WEIGHT kg	J kgm ²
10	112.8	35.6	13.5	0.0770
11 1/2	98.6	71.5	12.4	0.0956
14	84.4	68.6	14.8	0.2360

SINGLE BEARING DIMENSIONS

FAMCO
 هایپر صنعت

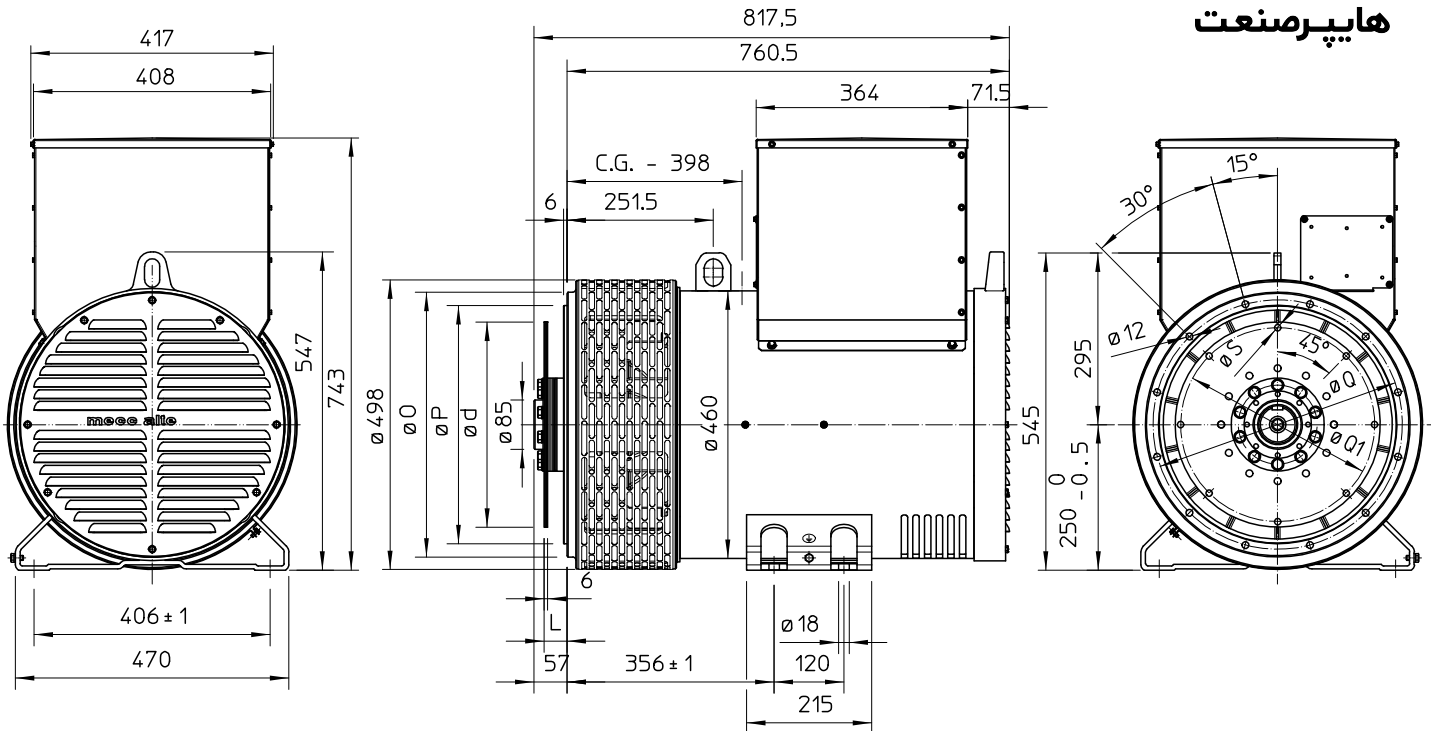

SAE N.	FLANGIA / FLANGE BRIDE / FLANSCH		
	O	P	Q
3	451	409.6	428.6
2	489	447.7	466.7
1	552	511.2	530.2

SAE N.	GIUNTI A DISCHI / DISC COUPLING DISCQUE DE MONOPALIER / SCHEIBENKUPPLUNG			
	L	d	Q1	S
10	53.8	314.32	295.27	11
11 1/2	39.6	352.42	333.37	11
14	25.4	466.72	438.15	14

C.G.= GRAVITY CENTER

Electrical Characteristics										
Frequency	Hz	50				60				
Voltage (series star)	V	380	400	415	440	415	440	460	480	
Rated power class H	kVA	135	135	135	114	140	150	162	162	
	kW	108	108	108	91	112	120	130	130	
Rated power class F	kVA	121	121	121	103	125	135	146	146	
	kW	97	97	97	82	100	108	117	117	
Regulation with DSR		±1% with any power factor and speed variations between -5% +30%								
Insulation class		H								
Execution		Brushless								
Stator winding		12 ends								
Rotor		with damping cage								
Efficiencies class H	4/4	%	92,8	92,9	92,6	92,4	94	94,5	94,7	94,8
(see graph. for details)	3/4	%	93,1	93,4	93,2	93	94,5	95	95,2	95,3
	2/4	%	91,6	91,7	91,7	91,6	93,1	93,3	93,5	93,6
	1/4	%	88,2	88,2	88,1	88	89,3	89,4	89,5	89,3
Reactances (f. l.cl. F)	Xd	%	245	222	202	161	257	250	241	222
	Xd'	%	16,8	15,4	14,4	11,5	19,5	18,0	16,8	15,4
	Xd''	%	8,1	7,6	6,9	5,4	9,7	8,9	8,1	7,6
	Xq	%	148	136	125	112	162	154	148	136
	Xq'	%	148	136	125	112	162	154	148	136
	Xq''	%	31,2	28,4	27,1	25,2	35,4	33	31,2	28,4
	X ₂	%	18,9	17,2	16,6	15,4	22,1	20,7	18,9	17,2
	X ₀	%	3,1	2,7	2,9	2,2	3,6	3,4	3,1	2,7
Short Circuit Ratio	Kcc		0,39	0,45	0,60	0,90	0,30	0,35	0,39	0,45
Time Constants	Td'	sec.	0,039							
	Td''	sec.	0,0085							
	Tdo'	sec.	1,85							
	Tα	sec.	0,0168							
Short Circuit Current Capacity		%	>300				>350			
Excitation at no load	Amp.		0,5	0,6	0,67	0,8	0,3	0,35	0,4	0,5
Excitation at full load	Amp.		2,1	2,1	2,2	2,4	2,3	2,1	2	2
Overload (long-term)	%	1 hour in a 6 hours period 110% rated load								
Overload per 20 sec.	%	300								
Stator Winding Resistance (20°C)	Ω	0,016								
Rotor Winding Resistance (20°C)	Ω	4,142								
Exciter Resistance (20 °C)	Ω	Rotor : 0,410				Stator : 15,28				
Heat dissipation at f.l.cl.H	W	8379	8254	8631	7501	7149	6984	7253	7109	
Telephone Interference		THF < 2%				TIF < 40				
Radio interference		EN61000-6-3, EN61000-6-2. For others standards apply to factory								
Waveform Distors.(THD) at f. load	LL/LN %	1,7 / 1,9								
Waveform Distors.(THD) at no load	LL/LN %	2,3 / 2,5								
Mechanical characteristics										
Protection		IP 21 (other protection on request)								
DE bearing		6314.2RS								
NDE bearing		6311.2RS								
Weight of wound stator assembly	kg	152								
Weight of wound rotor assembly	kg	101,3								
Weight of complete generator	kg	467								
Maximun overspeed	rpm	2250								
Unbalanced magnetic pull at f.l.cl.F	kN/mm	5,7								
Cooling air requirement	m ³ /min	19,3				23				
Inertia Constant (H)	sec.	0,098				0,118				
Noise level at 1m/7m	dB(A)	79 / 65				83 / 69				

All technical data are to be considered as a reference and they can be modified without any notice.

This document is a propriety of Mecc Alte S.p.a..All rights reserved.

50 Hz

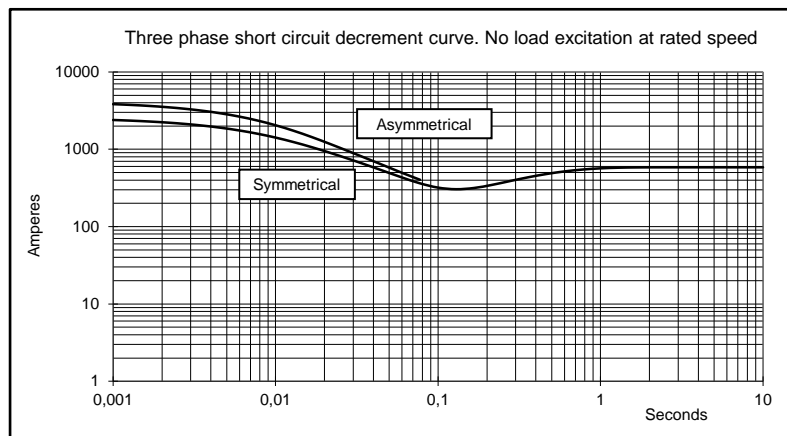
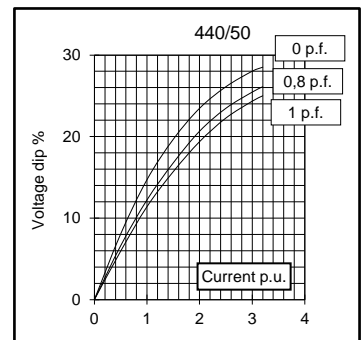
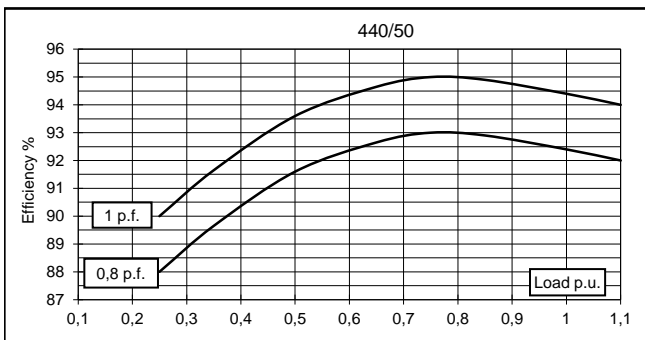
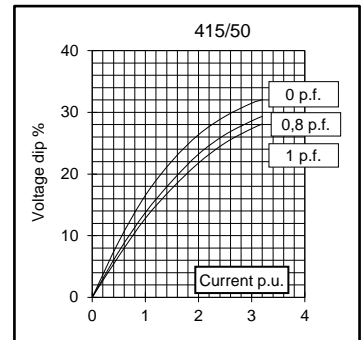
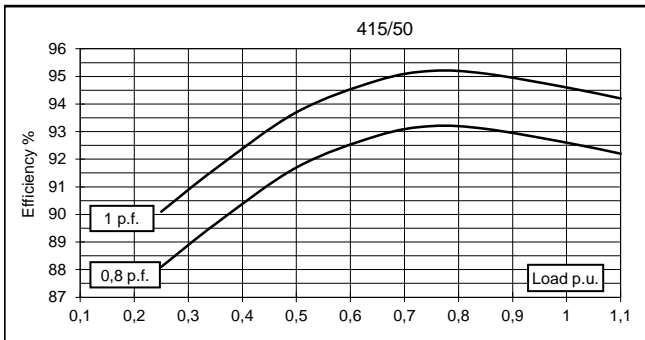
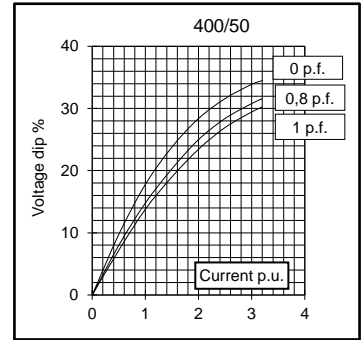
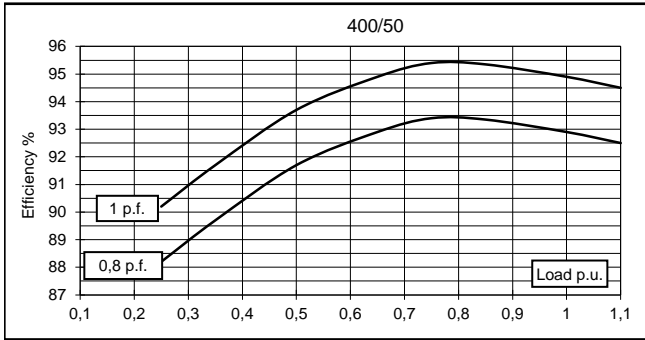
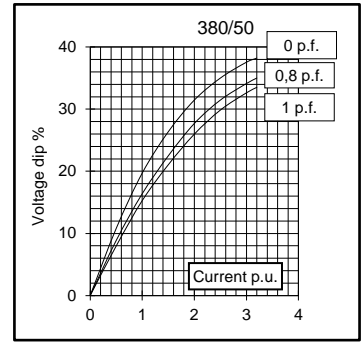
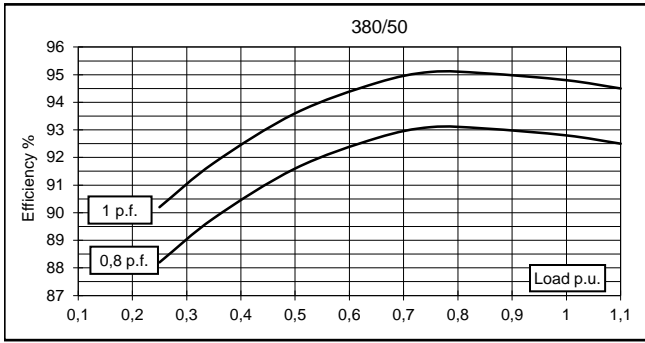

This document is a propriety of Mecc Alte S.p.a.. All rights reserved.

60 Hz

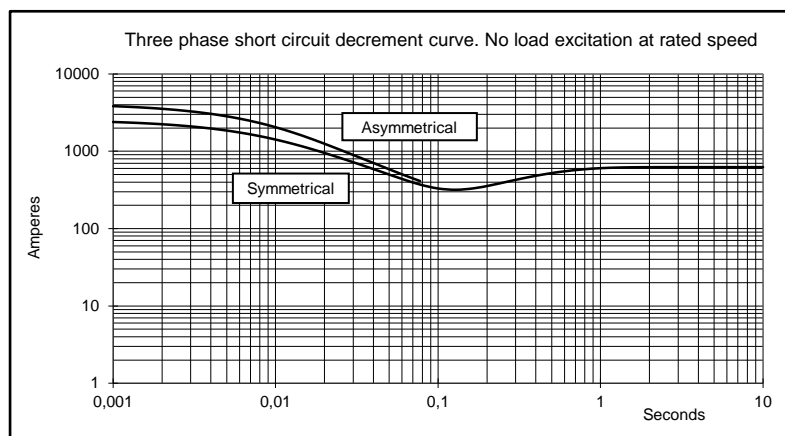
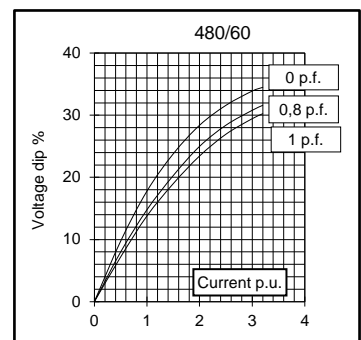
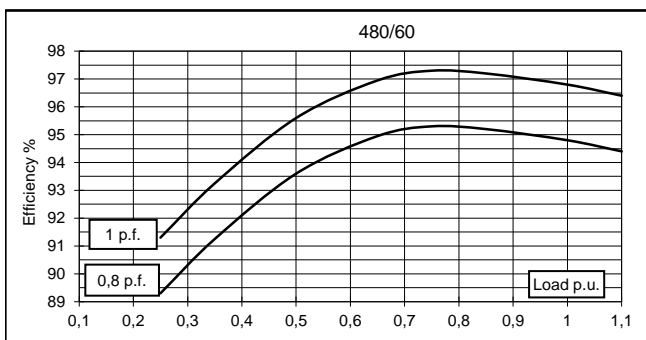
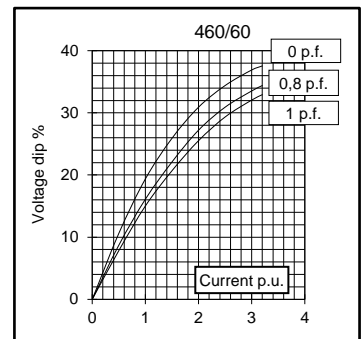
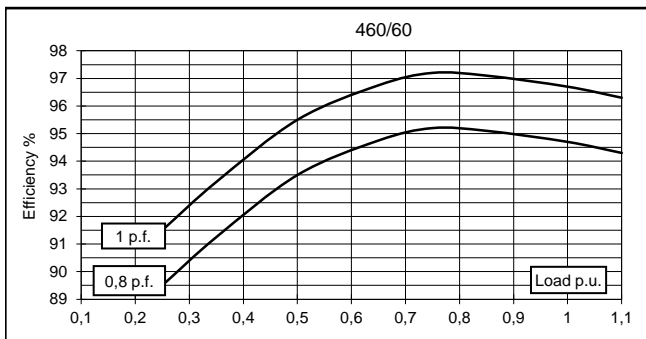
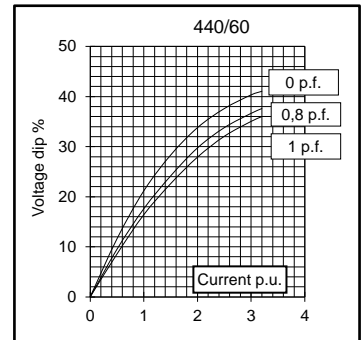
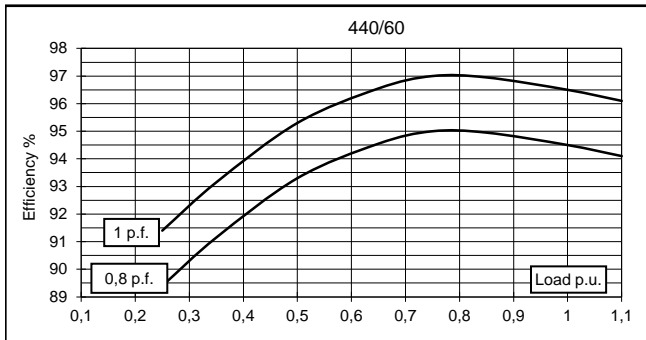
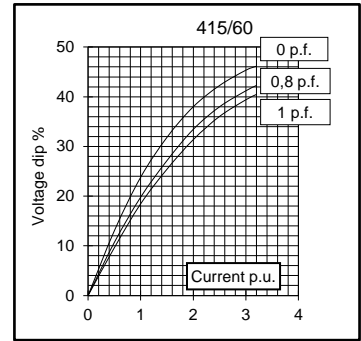
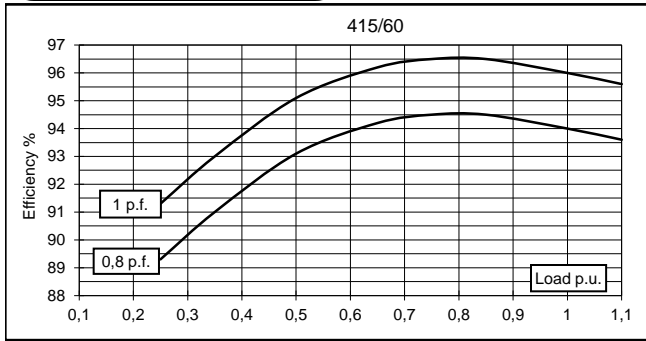

This document is a propriety of Mecc Alte S.p.a.. All rights reserved.

TWO BEARING MOMENTS OF INERTIA

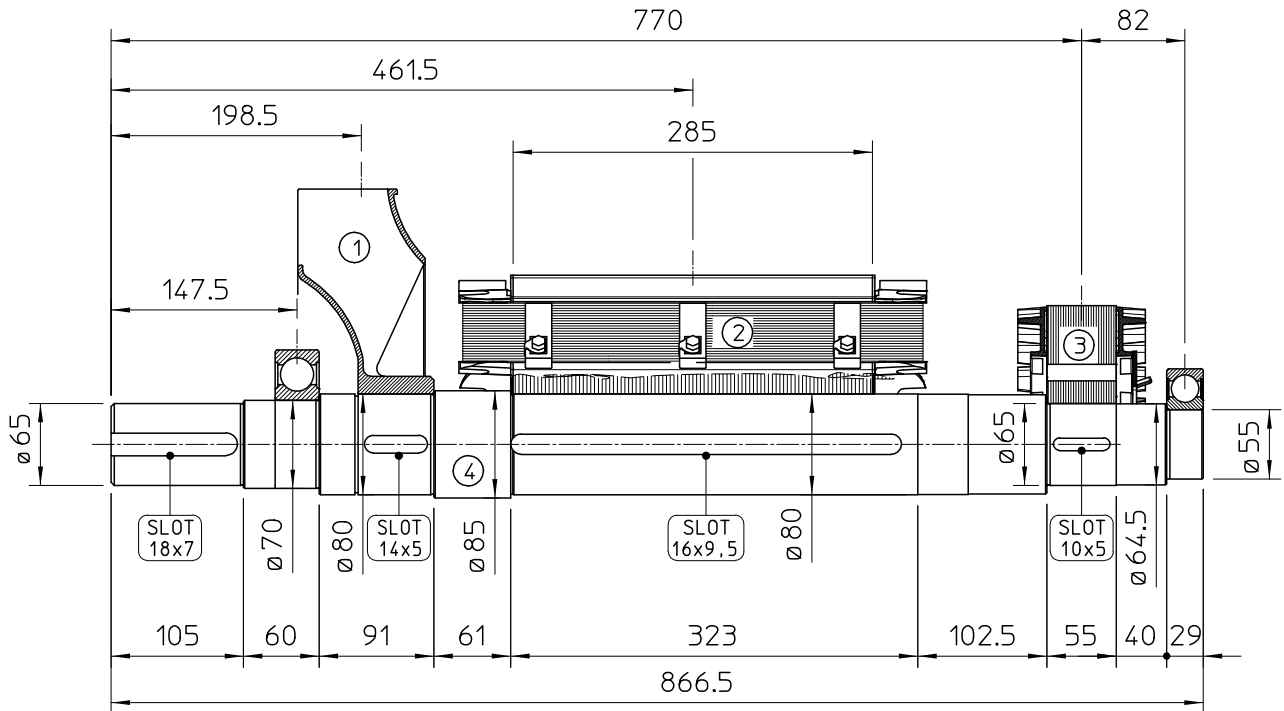

POS.	COMPONENT	WEIGHT (kg)	J (kgm ²)
1	FAN	3.6	0.0451
2	MAIN ROTOR	101.3	0.9153
3	EX. ROTOR	14.5	0.0874
4	SHAFT	29.6	0.0218
TOTAL		149	1.0696

TWO BEARING DIMENSIONS

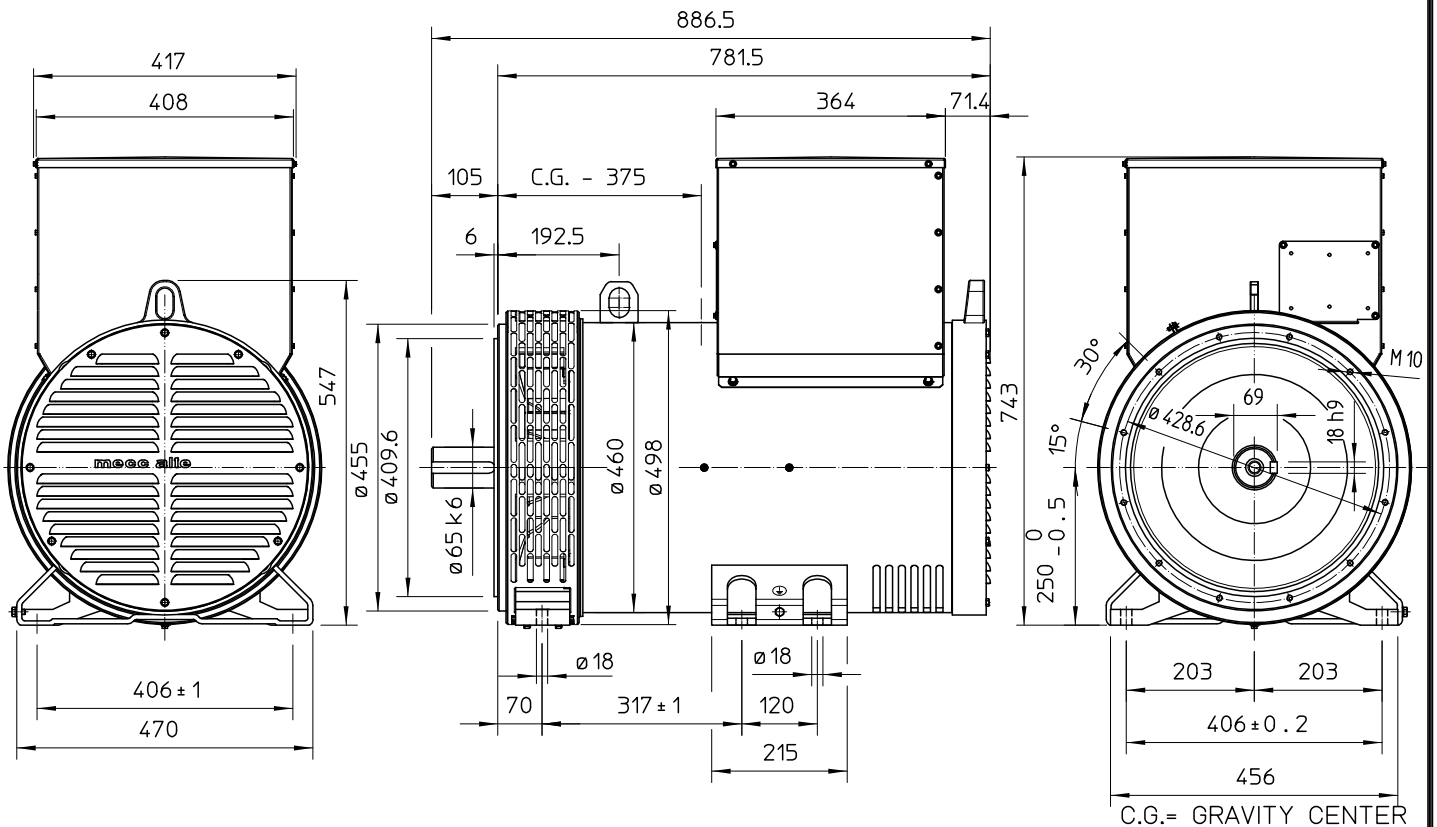

SINGLE BEARING MOMENTS OF INERTIA

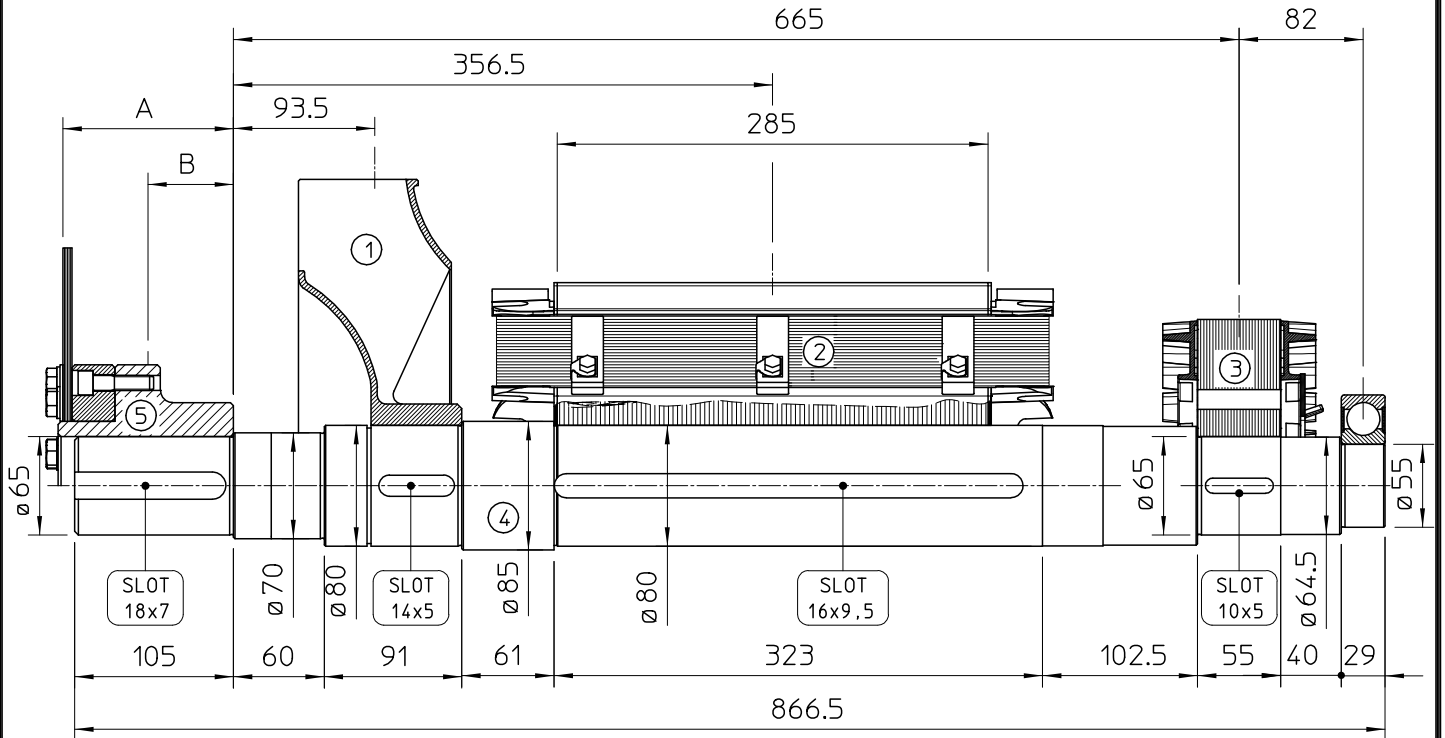

POS.	COMPONENT	WEIGHT (kg)	J (kgm ²)
1	FAN	3.6	0.0451
2	MAIN ROTOR	101.3	0.9153
3	EX. ROTOR	14.5	0.0874
4	SHAFT	29.6	0.0218
TOTAL		148.8	1.0696

SAE N°	5		SHAFTS COUPLING FLEX PLATE	
	A	B	WEIGHT kg	J kgm ²
10	112.8	35.6	13.5	0.0770
11 1/2	98.6	71.5	12.4	0.0956
14	84.4	68.6	14.8	0.2360

FAMCO
 هایپر صنعت

SINGLE BEARING DIMENSIONS

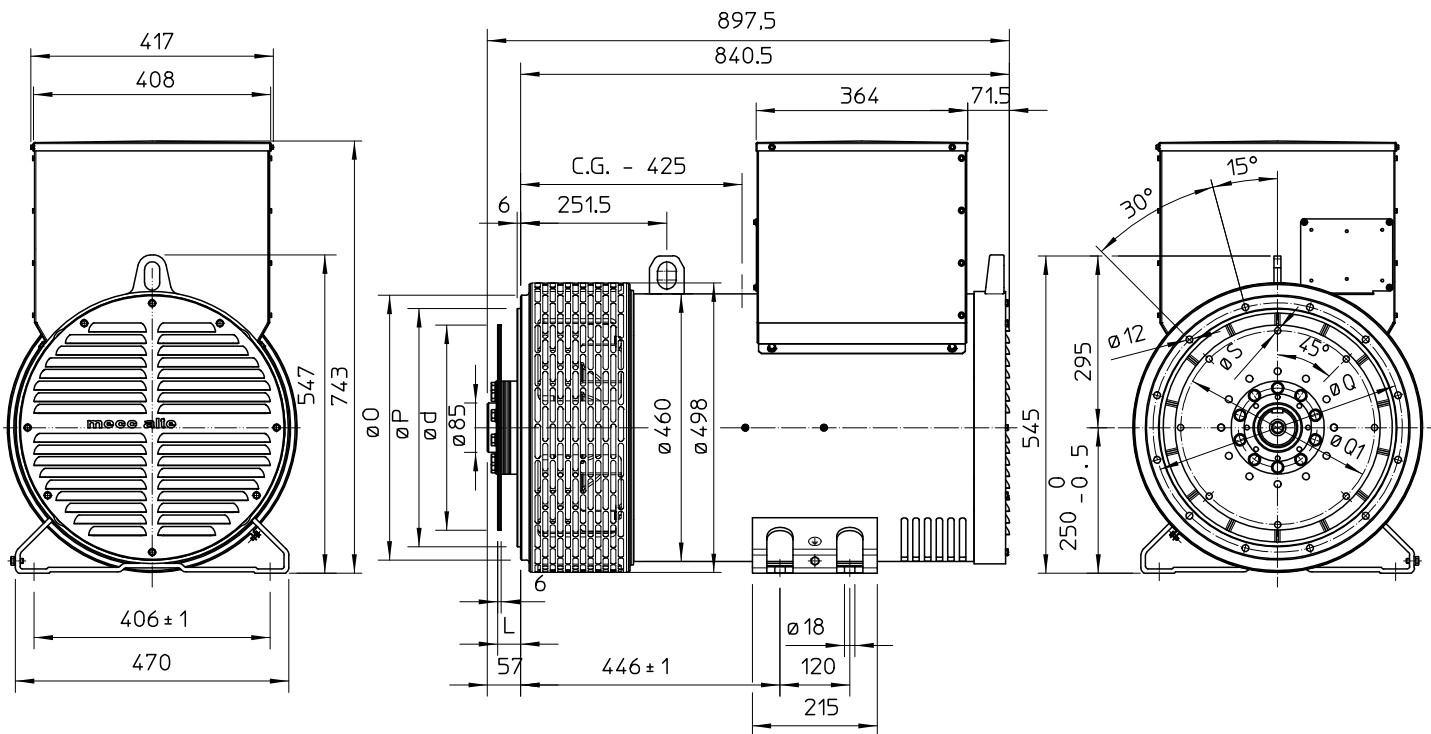

SAE N.	FLANGIA / FLANGE BRIDE / FLANSCH		
	O	P	Q
3	451	409.6	428.6
2	489	447.7	466.7
1	552	511.2	530.2

SAE N.	GIUNTI A DISCHI / DISC COUPLING DISQUE DE MONOPALIER / SCHEIBENKUPPLUNG			
	L	d	Q1	S
10	53.8	314.32	295.27	11
11 1/2	39.6	352.42	333.37	11
14	25.4	466.72	438.15	14

FAMCO
 هایپر صنعت

C.G.= GRAVITY CENTER

Electrical Characteristics										
Frequency	Hz	50				60				
Voltage (series star)	V	380	400	415	440	415	440	460	480	
Rated power class H	kVA	25	25	25	-	26	27,5	30	30	
	kW	20	20	20	-	20,8	22	24	24	
Rated power class F	kVA	23	23	23	-	24	25,5	27,5	27,5	
	kW	18,4	18,4	18,4	-	19,2	20,4	22	22	
Regulation with	SR7/2	±1,5 % with any power factor and speed variations between -5% +30%								
Insulation class		H								
Execution		Brushless								
Stator winding		12 ends								
Rotor		without damping cage								
Efficiencies class H	4/4	%	87,4	87,8	88,1	-	88,8	89,1	89,3	89,7
(see graph. for details)	3/4	%	87,8	88,1	88,2	-	89,4	89,6	89,8	90
	2/4	%	86	86,1	86,1	-	87,7	87,8	87,9	88
	1/4	%	83,8	83,6	83,6	-	85,9	85,7	85,9	85,8
Reactances (f. l.cl. F)	Xd	%	205,0	185	171,9	-	214,5	201,8	201,4	185
	Xd'	%	17,95	16,2	15,05	-	18,78	17,67	17,64	16,2
	Xd''	%	10,19	9,2	8,55	-	10,67	10,04	10,02	9,2
	Xq	%	84,2	76	70,6	-	88,1	82,9	82,8	76
	Xq'	%	84,2	76	70,6	-	88,1	82,9	82,8	76
	Xq''	%	23,3	21	19,5	-	24,3	22,9	22,9	21
	X ₂	%	15,18	13,7	12,73	-	15,88	14,95	14,92	13,7
	X ₀	%	3,43	3,1	2,88	-	3,59	3,38	3,38	3,1
Short Circuit Ratio	Kcc		0,50	0,58	0,80	-	0,38	0,43	0,50	0,58
Time Constants	Td'	sec.	0,047							
	Td''	sec.	0,013							
	Tdo'	sec.	0,93							
	Tα	sec.	0,011							
Short Circuit Current Capacity		%	>300				>350			
Excitation at no load	Amp.		0,45	0,6	0,7	-	0,3	0,4	0,5	0,55
Excitation at full load	Amp.		1,4	1,6	1,8	-	1,3	1,4	1,5	1,6
Overload (long-term)		%	1 hour in a 6 hours period 110% rated load							
Overload per 20 sec.		%	300							
Stator Winding Resistance (20°C)	Ω		0,128							
Rotor Winding Resistance (20°C)	Ω		1,67							
Exciter Resistance (20 °C)	Ω		Rotor : 0,417				Stator : 10,60			
Heat dissipation at f.l.cl.H	W		2883	2779	2701	-	2623	2691	2876	2756
Telephone Interference			FHT < 2%				TIF < 45			
Radio interference			EN60034-1. For others standards apply to factory							
Waveform Distors.(THD) at f. load	LL/LN %		2 / 2							
Waveform Distors.(THD) at no load	LL/LN %		3,4 / 3,2							
Mechanical characteristics										
Protection			IP 23 (other protection on request)							
DE bearing			6309-2RS							
NDE bearing			6209-2RS							
Weight of wound stator assembly	kg		50							
Weight of wound rotor assembly	kg		27							
Weight of complete generator	kg		139							
Maximun overspeed	rpm		2250							
Unbalanced magnetic pull at f.l.cl.F	kN/mm		4,5							
Cooling air requirement	m ³ /min		5,3				5,8			
Inertia Constant (H)	sec.		0,082				0,099			
Noise level at 1m/7m	dB(A)		68 / 57				71 / 61			

All technical data are to be considered as a reference and they can be modified without any notice

This document is a propriety of Mecc Alte S.p.a..All rights reserved.

50 Hz
FAMCO
هایپر صنعت

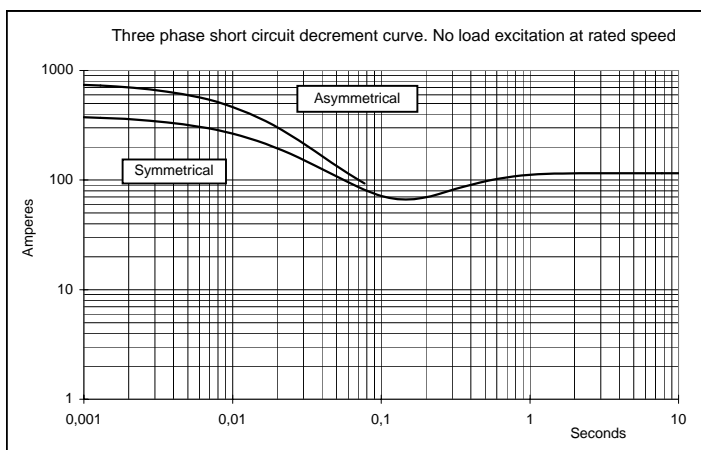
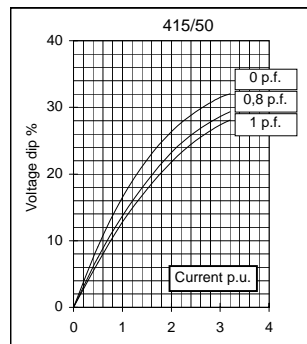
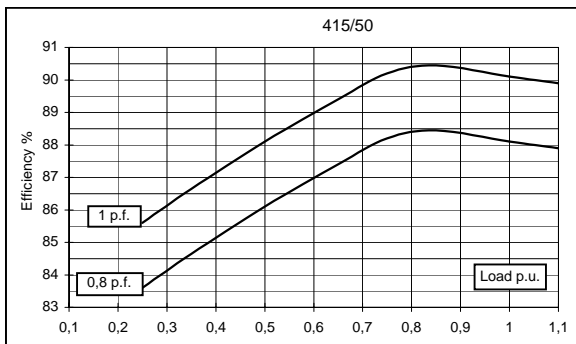
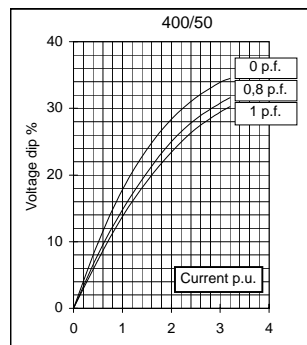
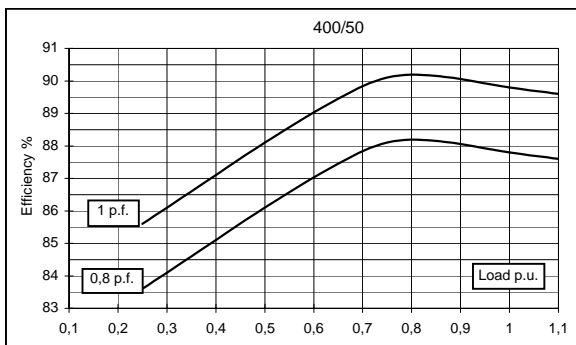
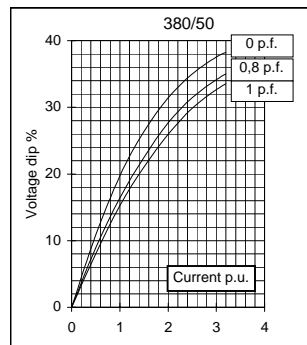
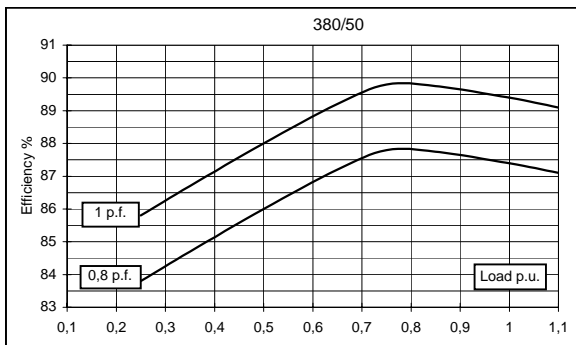

This document is a propriety of Mecc Alte S.p.a.. All rights reserved.

60 Hz

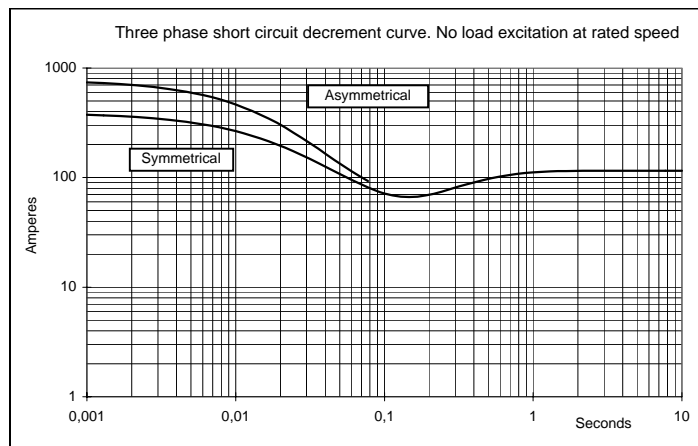
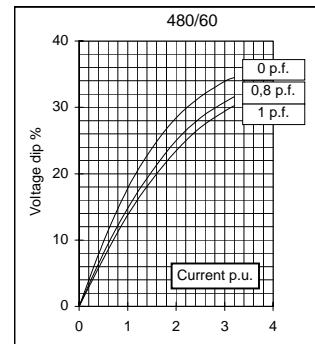
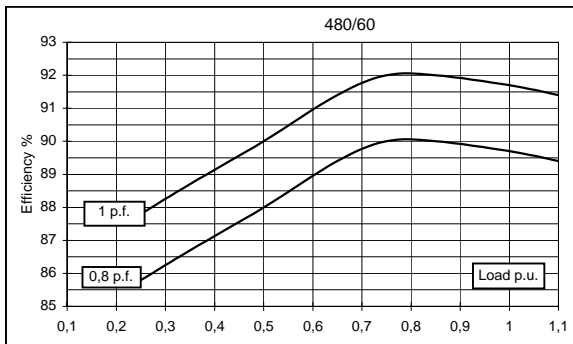
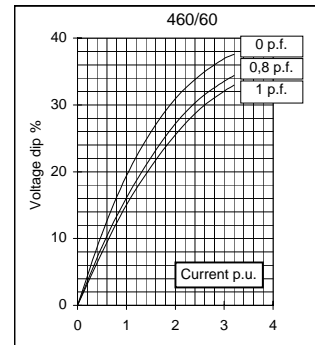
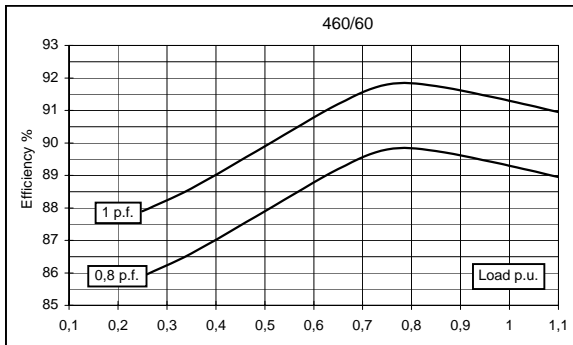
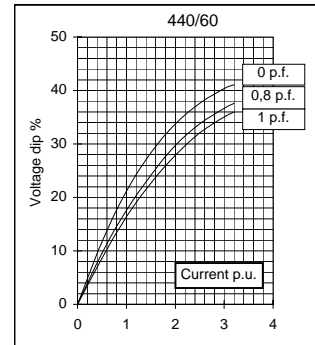
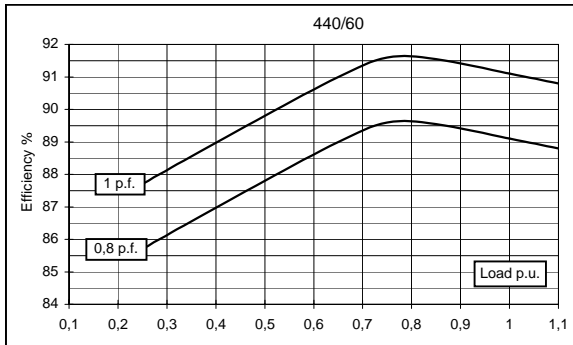
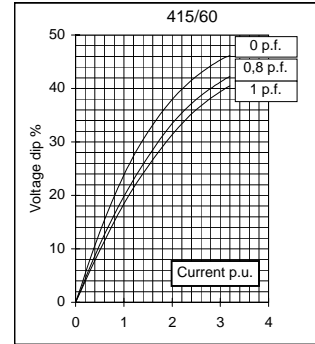
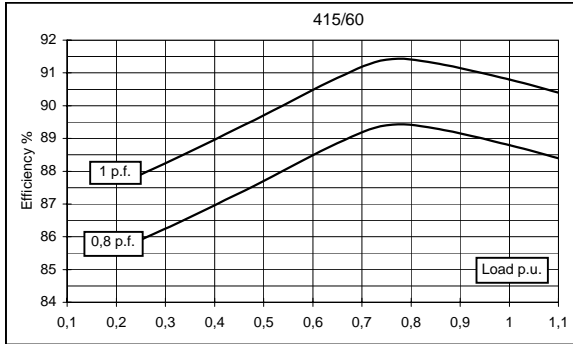

This document is a propriety of Mecc Alte S.p.a.. All rights reserved.

TWO BEARING MOMENTS OF INERTIA

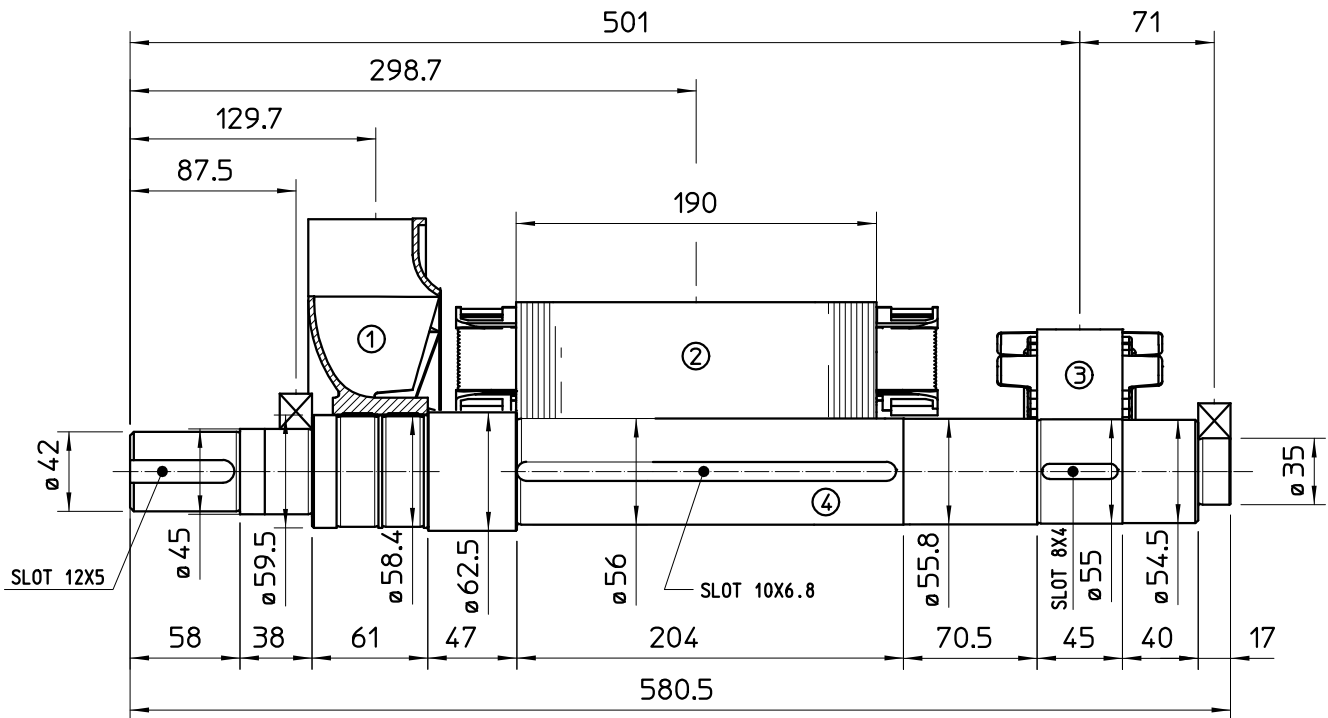

COMPONENT	WEIGHT Kg	J Kg ^{m2}
1 FAN	1.2	0.0102
2 MAIN ROTOR	26.8	0.117
3 EX ROTOR	5.4	0.012
4 SHAFT	10.6	0.004
6 TOTAL	44	0.1432

FAMCO
هایپر صنعت

TWO BEARING DIMENSIONS

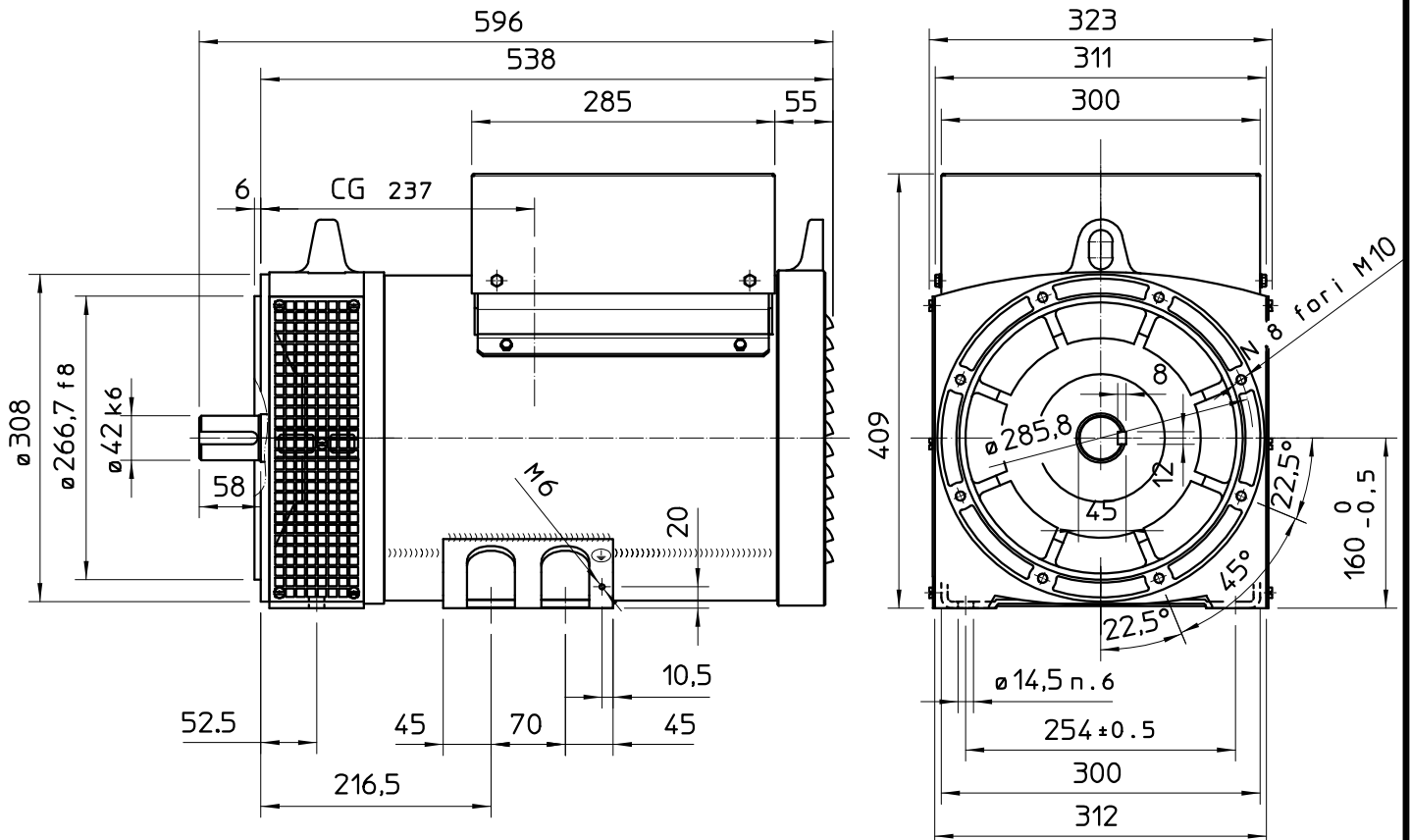

C.G. = GRAVITY CENTER

SINGLE BEARING MOMENTS OF INERTIA

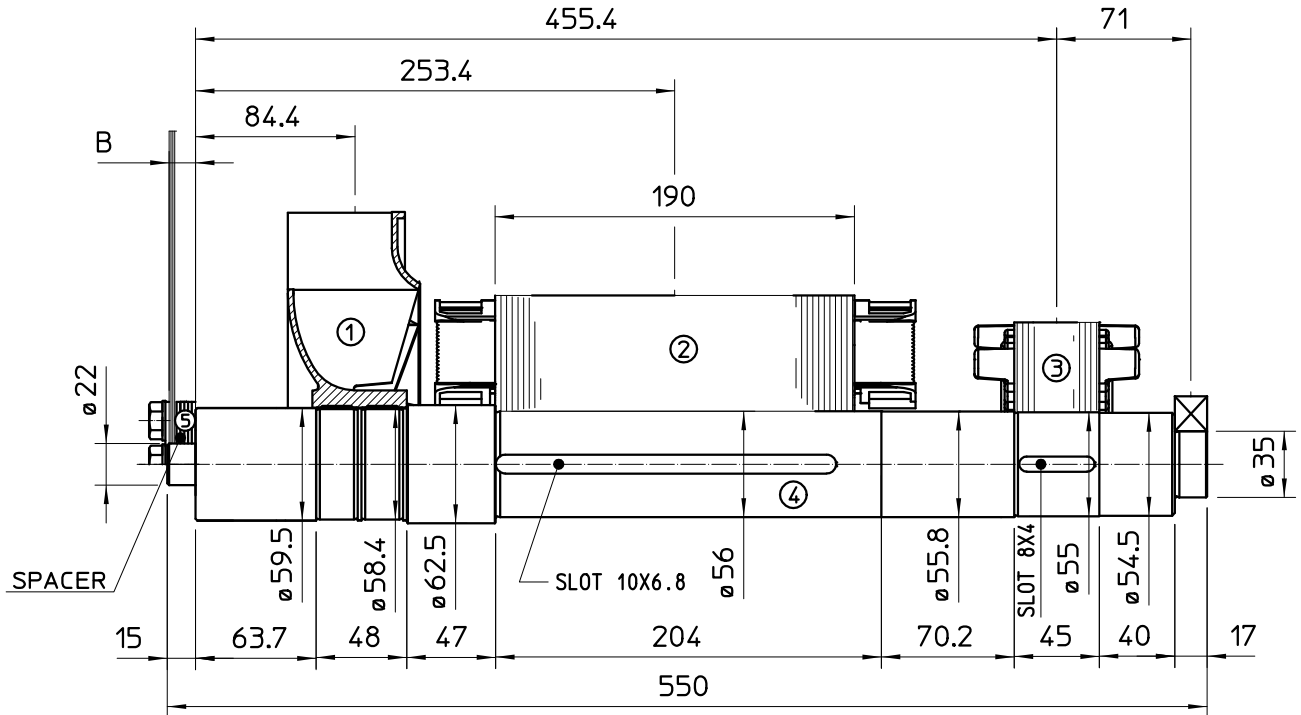

COMPONENT	WEIGHT Kg	J Kg ²
1 FAN	1.2	0.0102
2 MAIN ROTOR	26.8	0.117
3 EX ROTOR	5.4	0.012
4 SHAFT	10.5	0.0041
6 TOTAL	43.9	0.1433

SAE N.	5	SHAFT COUPLING FLEX PLATE	
	B(mm)	WEIGHT kg	J kgm ²
6 1/2	4	1.14	0.0067
7 1/2	4	1.42	0.0103
8	35.6	1.97	0.0171
10	27.6	2.59	0.0319
11 1/2	14	3.1	0.0481

FAMCO
هایپرمنت

SINGLE BEARING DIMENSIONS

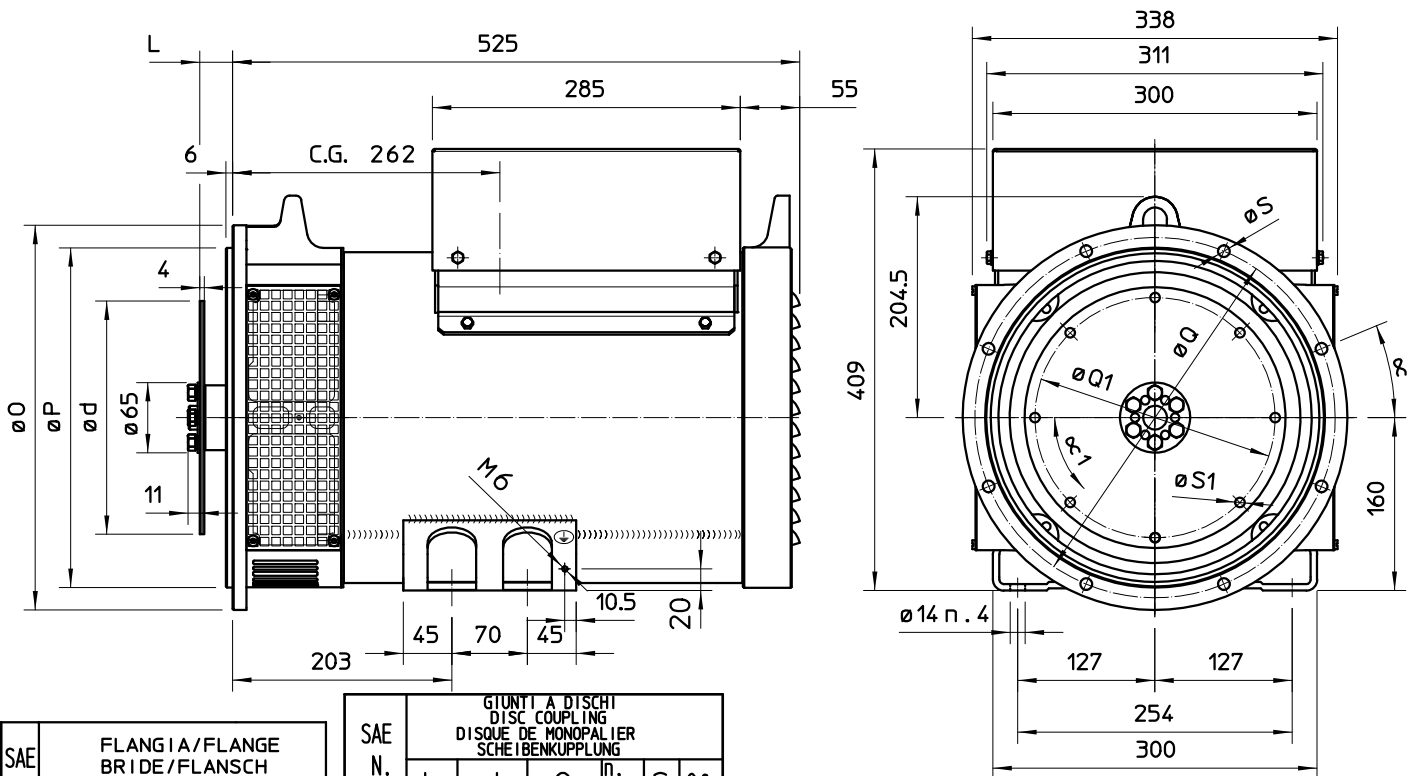

SAE N.	FLANGIA/FLANGE BRIDE/FLANSCH					
	O	P	Q	n. fori	S	α
5	356	314.3	333.4	8	11	22°30'
4	403	362	381	12	11	15°
3	451	409.6	428.6	12	11	15°
2	489	447.7	466.7	12	11	15°

SAE N.	GIUNTI A DISCHI DISC COUPLING DISQUE DE MONOPALIER SCHEIBENKUPPLUNG					
	L	d	Q1	n. fori	S1	α1
6 1/2	30.2	215.9	200	6	9	60°
7 1/2	30.2	241.3	222.25	8	9	45°
8	62	263.52	244.47	6	11	60°
10	53.8	314.32	295.27	8	11	45°
11 1/2	39.6	352.42	333.37	8	11	45°

FAMCO
هایپرمنت

C.G. = GRAVITY CENTER

Electrical Characteristics										
Frequency	Hz	50				60				
Voltage (series star)	V	380	400	415	440	415	440	460	480	
Rated power class H	kVA	20	20	20	18	21	23	24	24	
	kW	16	16	16	14,4	16,8	18,4	19,2	19,2	
Rated power class F	kVA	18,5	18,5	18,5	17	19	20	22	22	
	kW	14,8	14,8	14,8	13,6	15,2	16	17,6	17,6	
Regulation with SR7/2		±1,5 % with any power factor and speed variations between -5% +30%								
Insulation class		H								
Execution		Brushless								
Stator winding		12 ends								
Rotor		without damping cage								
Efficiencies class H	4/4	%	87,3	87,4	87,1	86,9	88,8	89,3	89,4	89,5
(see graph. for details)	3/4	%	87,5	87,8	87,5	87,4	88,9	89,1	89,3	89,5
	2/4	%	85,5	85,6	85,6	85,5	87,2	87,3	87,4	87,5
	1/4	%	83,1	83	82,8	82,3	85,1	85,1	85,1	85
Reactances (f. l.cl. F)	Xd	%	199,4	180	167,2	133,9	210,7	205,3	196,0	180
	Xd'	%	18,61	16,8	15,61	12,50	19,67	19,16	18,29	16,8
	Xd''	%	10,64	9,6	8,92	7,14	11,24	10,95	10,45	9,6
	Xq	%	86,4	78	72,5	58,0	91,3	89,0	84,9	78
	Xq'	%	86,4	78	72,5	58,0	91,3	89,0	84,9	78
	Xq''	%	24,4	22	20,4	16,4	25,8	25,1	24,0	22
	X ₂	%	15,96	14,4	13,38	10,71	16,86	16,42	15,68	14,4
	X ₀	%	3,66	3,3	3,07	2,45	3,86	3,76	3,59	3,3
Short Circuit Ratio	Kcc		0,53	0,62	0,87	1,45	0,41	0,48	0,53	0,62
Time Constants	Td'	sec.	0,044							
	Td''	sec.	0,014							
	Tdo'	sec.	0,85							
	T _α	sec.	0,012							
Short Circuit Current Capacity		%	>300				>320			
Excitation at no load	Amp.		0,4	0,5	0,6	0,8	0,3	0,35	0,4	0,5
Excitation at full load	Amp.		1,4	1,5	1,7	1,9	1,2	1,3	1,4	1,5
Overload (long-term)	%	1 hour in a 6 hours period 110% rated load								
Overload per 20 sec.	%	300								
Stator Winding Resistance (20°C)	Ω	0,198								
Rotor Winding Resistance (20°C)	Ω	1,396								
Exciter Resistance (20 °C)	Ω	Rotor : 0,417				Stator : 10,60				
Heat dissipation at f.l.cl H	W	2328	2307	2370	2171	2119	2205	2277	2253	
Telephone Interference		THF < 2%				TIF < 45				
Radio interference		EN60034-1. For others standards apply to factory								
Waveform Distors.(THD) at f. load	LL/LN %	2 / 2								
Waveform Distors.(THD) at no load	LL/LN %	3,6 / 3,5								
Mechanical characteristics										
Protection		IP 23 (other protection on request)								
DE bearing		6309-2RS								
NDE bearing		6209-2RS								
Weight of wound stator assembly	kg	41								
Weight of wound rotor assembly	kg	21								
Weight of complete generator	kg	122								
Maximun overspeed	rpm	2250								
Unbalanced magnetic pull at f.l.cl.F	kN/mm	3,8								
Cooling air requirement	m ³ /min	5,3				5,8				
Inertia Constant (H)	sec.	0,087				0,104				
Noise level at 1m/7m	dB(A)	68 / 57				71 / 61				

50 Hz

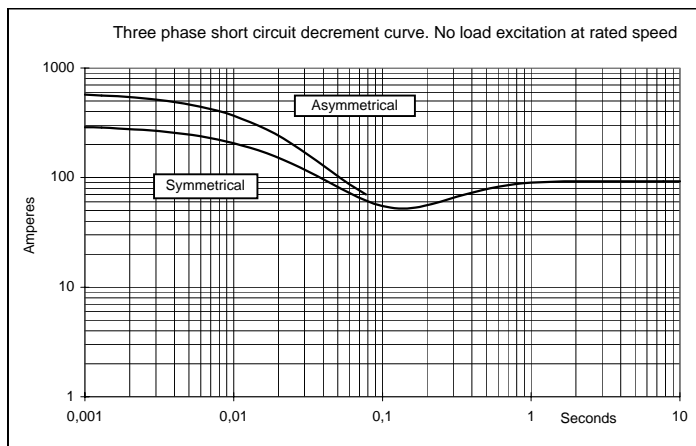
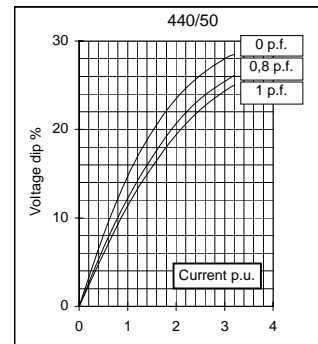
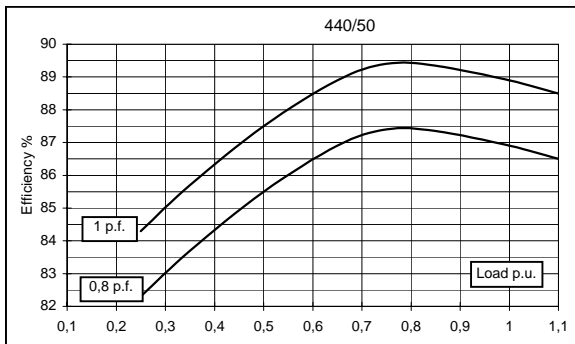
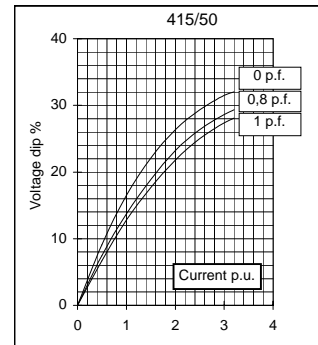
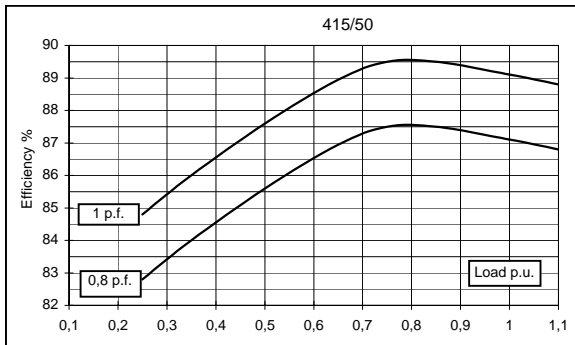
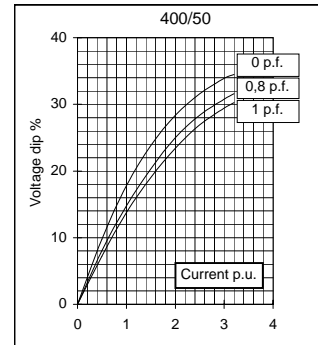
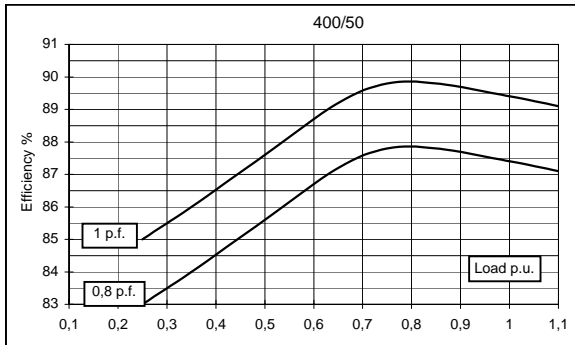
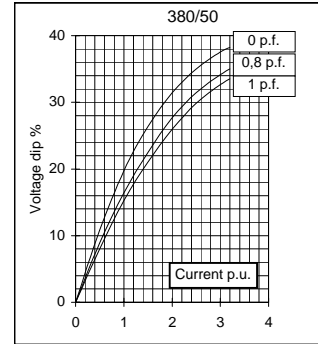
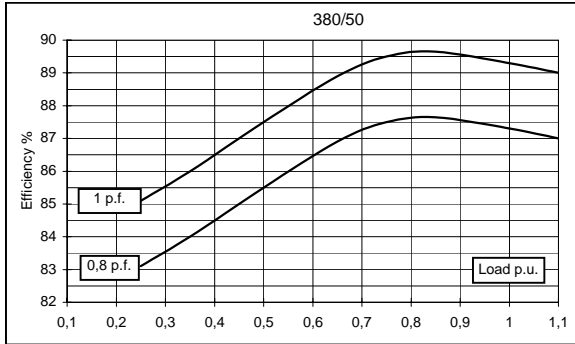

This document is a propriety of Mecc Alte S.p.a.. All rights reserved.

60 Hz

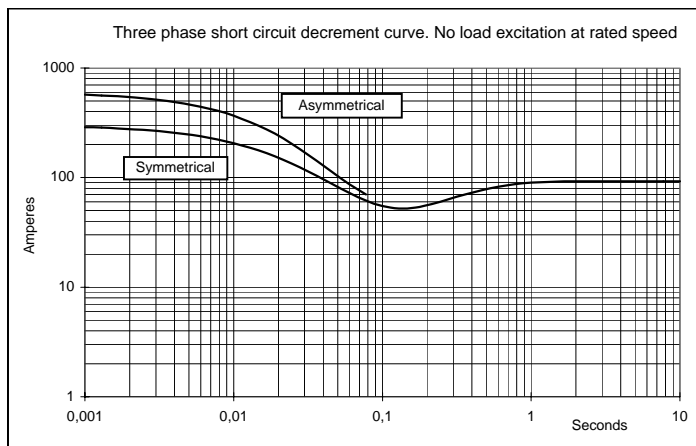
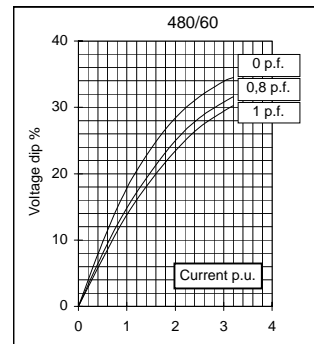
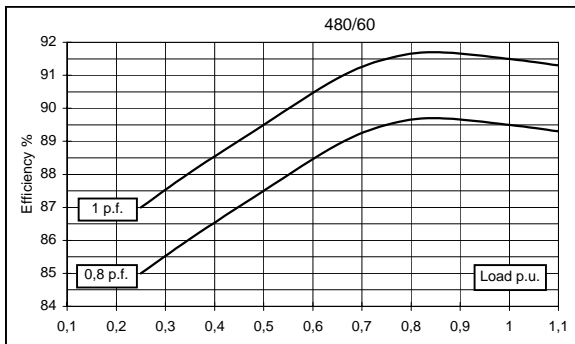
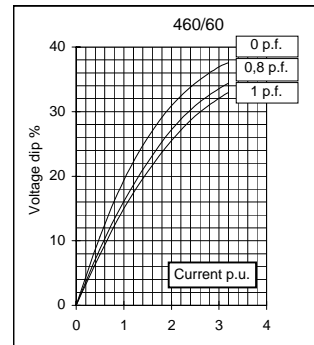
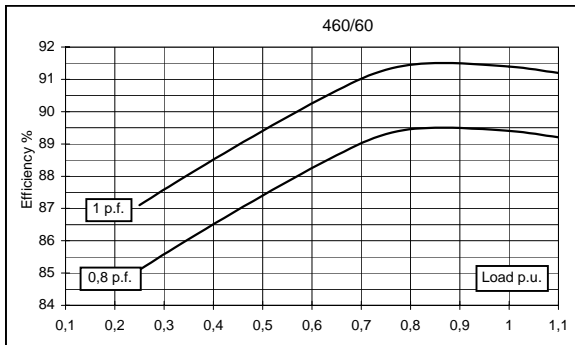
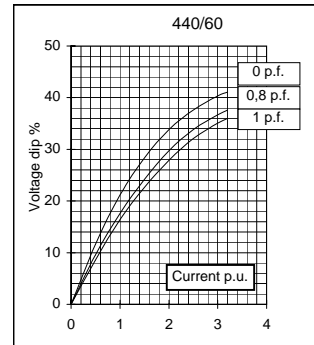
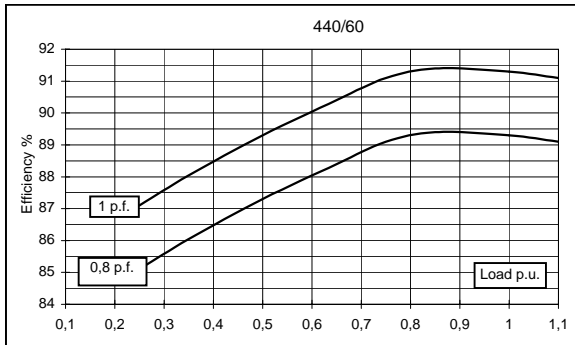
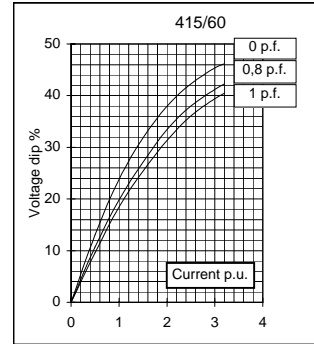
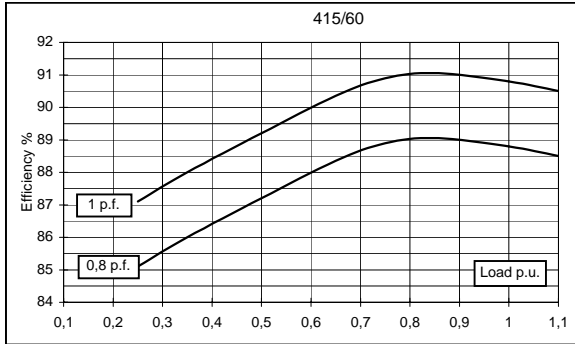

This document is a propriety of Mecc Alte S.p.a.. All rights reserved.

TWO BEARING MOMENTS OF INERTIA

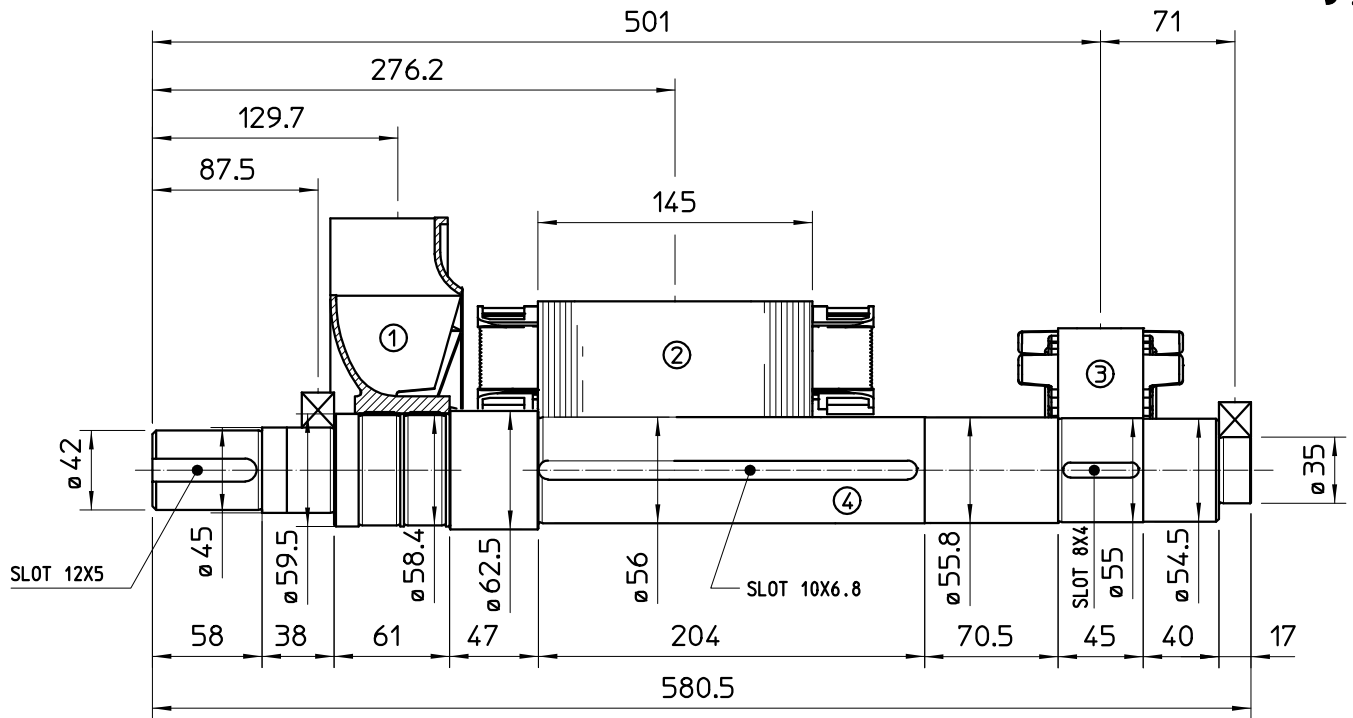

COMPONENT	WEIGHT Kg	J Kg ^m ²
1 FAN	1.2	0.0102
2 MAIN ROTOR	20.9	0.0914
3 EX ROTOR	5.4	0.012
4 SHAFT	10.6	0.004
6 TOTAL	38.1	0.1176



TWO BEARING DIMENSIONS

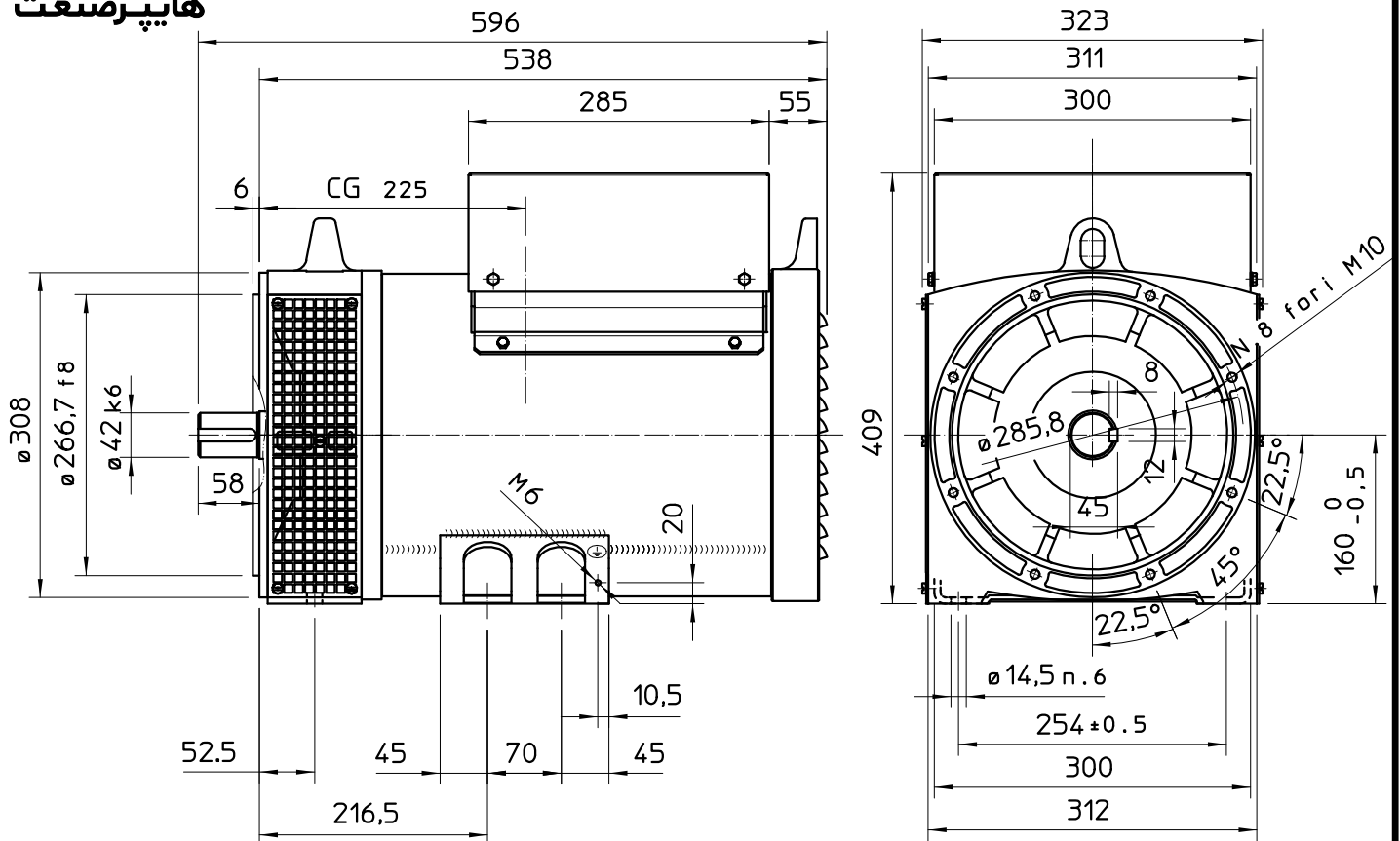

C.G. = GRAVITY CENTER

SINGLE BEARING MOMENTS OF INERTIA

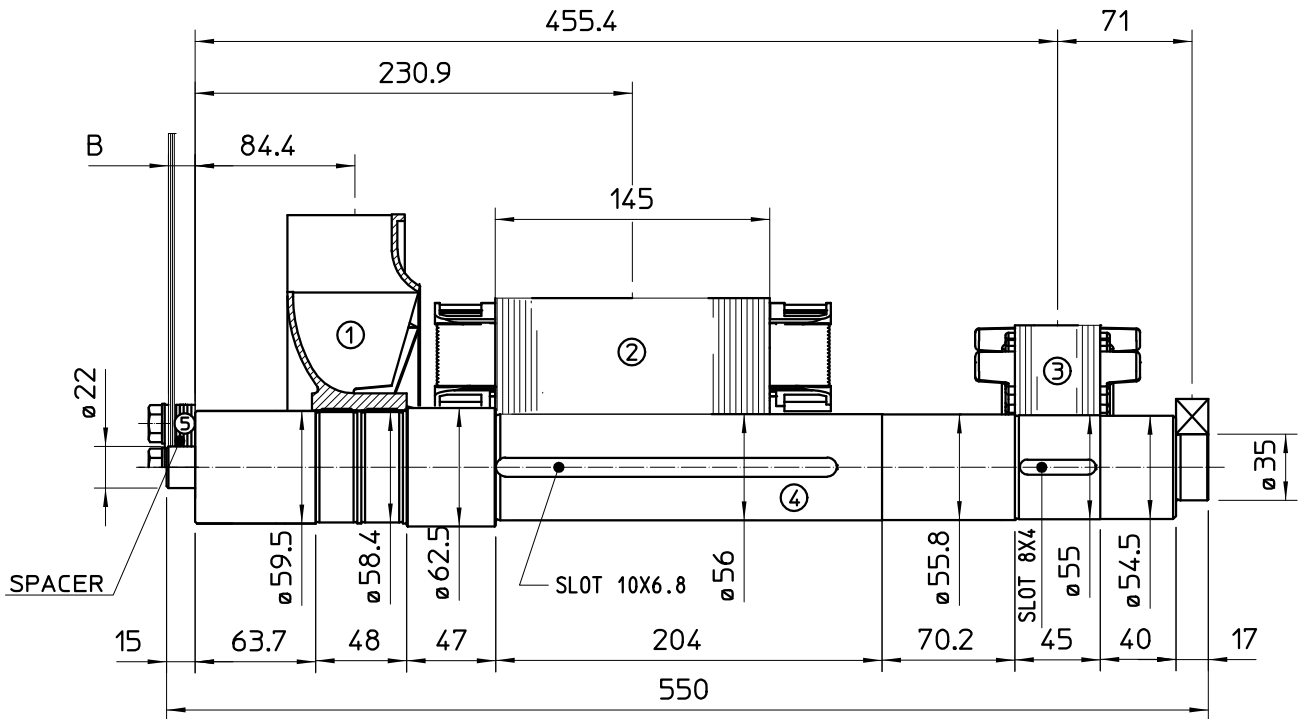

COMPONENT	WEIGHT Kg	J Kg ²
1 FAN	1.2	0.0102
2 MAIN ROTOR	20.9	0.0914
3 EX ROTOR	5.4	0.012
4 SHAFT	10.5	0.0041
6 TOTAL	38	0.1177

SAE N.	5	SHAFT COUPLING FLEX PLATE	
	B (mm)	WEIGHT kg	J kg ²
6 1/2	4	1.14	0.0067
7 1/2	4	1.42	0.0103
8	35.6	1.97	0.0171
10	27.6	2.59	0.0319
11 1/2	14	3.1	0.0481

SINGLE BEARING DIMENSIONS

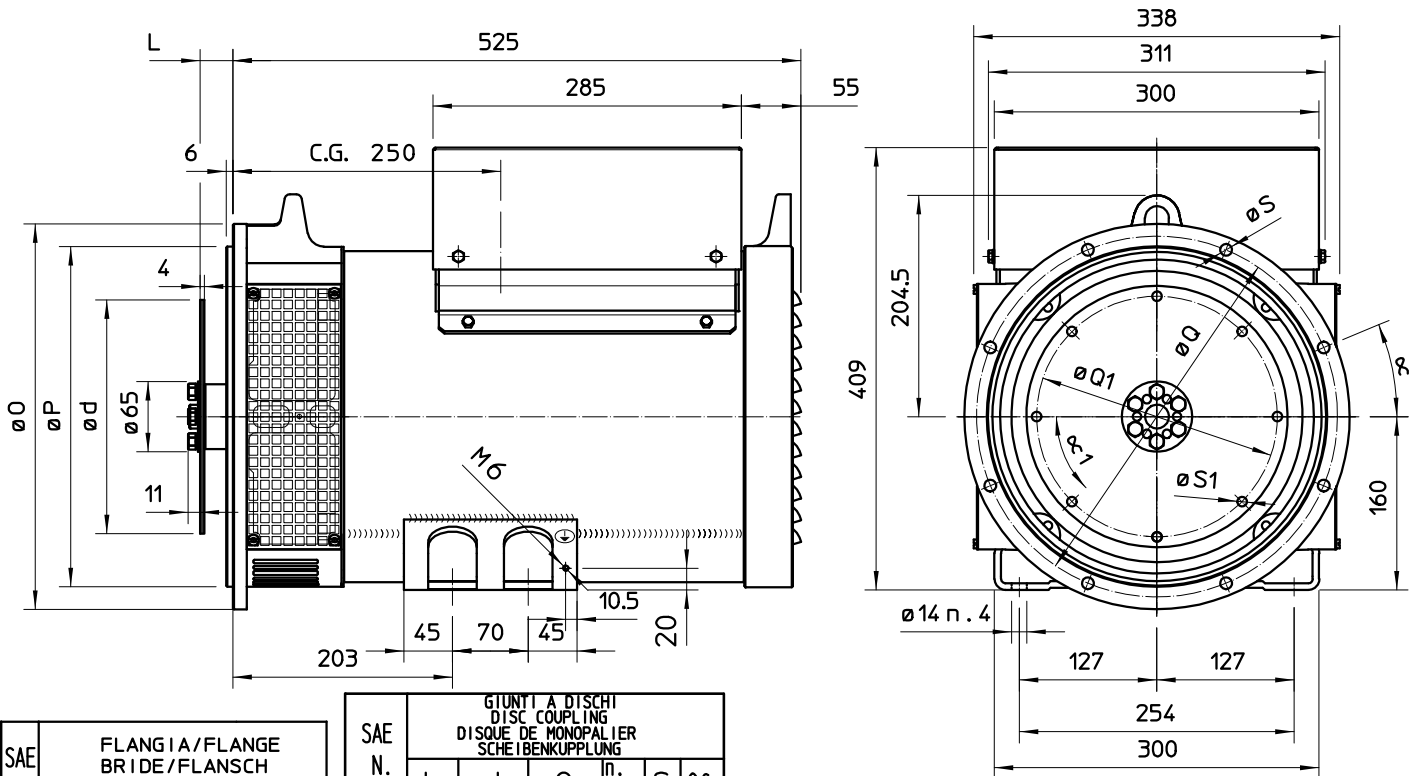

SAE N.	FLANGIA/FLANGE BRIDE/FLANSCH					
	O	P	Q	n. for i	S	α
5	356	314.3	333.4	8	11	22°30'
4	403	362	381	12	11	15°
3	451	409.6	428.6	12	11	15°
2	489	447.7	466.7	12	11	15°

SAE N.	GIUNTI A DISCHI DISC COUPLING DISQUE DE MONOPALIER SCHEIBENKUPPLUNG					
	L	d	Q1	n. for i	S1	α1
6 1/2	30.2	215.9	200	6	9	60°
7 1/2	30.2	241.3	222.25	8	9	45°
8	62	263.52	244.47	6	11	60°
10	53.8	314.32	295.27	8	11	45°
11 1/2	39.6	352.42	333.37	8	11	45°

C.G. = GRAVITY CENTER