

ACm
Centrifugal Pump



Application

- Can be used to transfer clean water or other liquids similar to water in physical and chemical properties
- Suitable for industrial use and urban water supply, pressure boosting for high buildings and fire fighting, garden irrigation, long-distance water transfer, heating ventilation and air conditioning, circulation and pressure boosting for cold and hot water, and supporting equipment etc.

Pump

- Cast iron pump body and support under special anti-rust treatment
- AISI 304 shaft
- Max. liquid temperature: +60°C
- Max. suction: +8 m

Motor

- Low noise & Long life bearing
- Motor with copper winding
- Built-in thermal protector for single phase motor
- Insulation class: F
- Enclosures class: IPX4
- Max. ambient temperature: +50°C
- IE 2 motor (Three phase, power ≥ 0.75kW)

Identification Codes

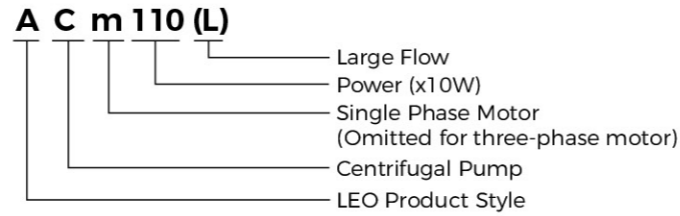

Technical Data

Model	Power	Q(m³/h)	H (m)																							
			0	0.6	0.9	1.2	1.8	2.4	3.0	3.6	4.2	4.5	4.8	5.4	6.0	6.6	7.2	7.8	8.4	9.0	9.6	10.8	11.7	12.6		
Single Phase	Three Phase	kW	HP	Q(l/min)	0	10	15	20	30	40	50	60	70	75	80	90	100	110	120	130	140	150	160	180	195	200
ACm25	-	0.25	0.3		17	16.5	16.2	16	15.5	14.5	13.5	12.5	10.5	9.5	8	-	-	-	-	-	-	-	-	-	-	-
ACm37	-	0.37	0.5		23	21.5	21	21	20.5	19.5	18	17	15.5	14.5	14	12	-	-	-	-	-	-	-	-	-	-
ACm60	AC60	0.5	0.8		27	26.5	26.2	26	25	24.5	22.5	20	17	15.5	14	10	-	-	-	-	-	-	-	-	-	-
ACm75	AC75	0.75	1		36	35	34	33.5	33	32	31	29	27	26	23.5	20	16	-	-	-	-	-	-	-	-	-
ACm110	AC110	1.1	1.5		40	39	38	38	37.5	37	36	35	33	32	31	29	26	23	20	-	-	-	-	-	-	-
ACm150	AC150	1.5	2		48	47.5	47	46.5	45.5	44.5	43.5	42.5	41.5	41	40.5	39	37	34.5	31	27	22	-	-	-	-	-
-	AC220	2.2	3		55	54.5	53	53.5	53	52.5	51.5	50.5	49.5	48	48.5	47	45.5	43.5	40	36.5	32.5	28	-	-	-	-
ACm110L	AC110L	1.1	1.5		34.5	34.3	34.2	34.1	34	33.8	33.5	33	32.5	32.3	32	31	30.5	29.5	28.5	27.5	26.5	25	23.5	20	16.5	-
ACm150L	AC150L	1.5	2		37.5	37.2	37	36.9	36.6	36.2	35.8	35.4	35	34.8	34.7	34	33.3	32.5	31.5	30.5	29.5	28.2	27	24	21	19

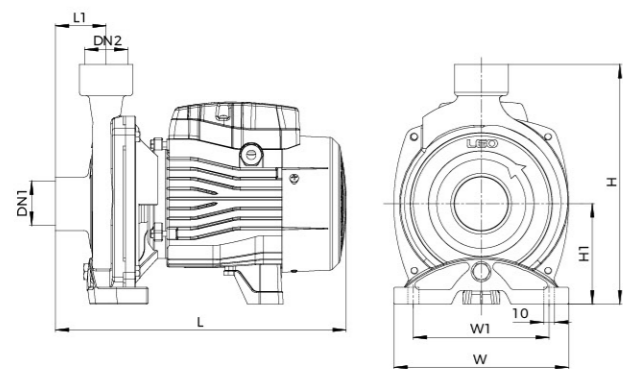

Dimension

Model	DN1	DN2	L (mm)	W (mm)	H (mm)	L1 (mm)	W1 (mm)	H1 (mm)
ACm25	1"	1"	257	157	216	40	123	90
ACm37			257	157	216	40	123	90
ACm60			303	190	240	45	160	100
ACm75	1 1/4"	1"	303	190	240	45	160	100
ACm110			359	206	265	50	178	112
ACm150			360	240	286	52	207	115
AC220	1 1/2"	1"	360	240	286	52	207	115
ACm110L			359	206	265	50	178	112
ACm150L			359	206	265	50	178	112

Hydraulic Performance Curves

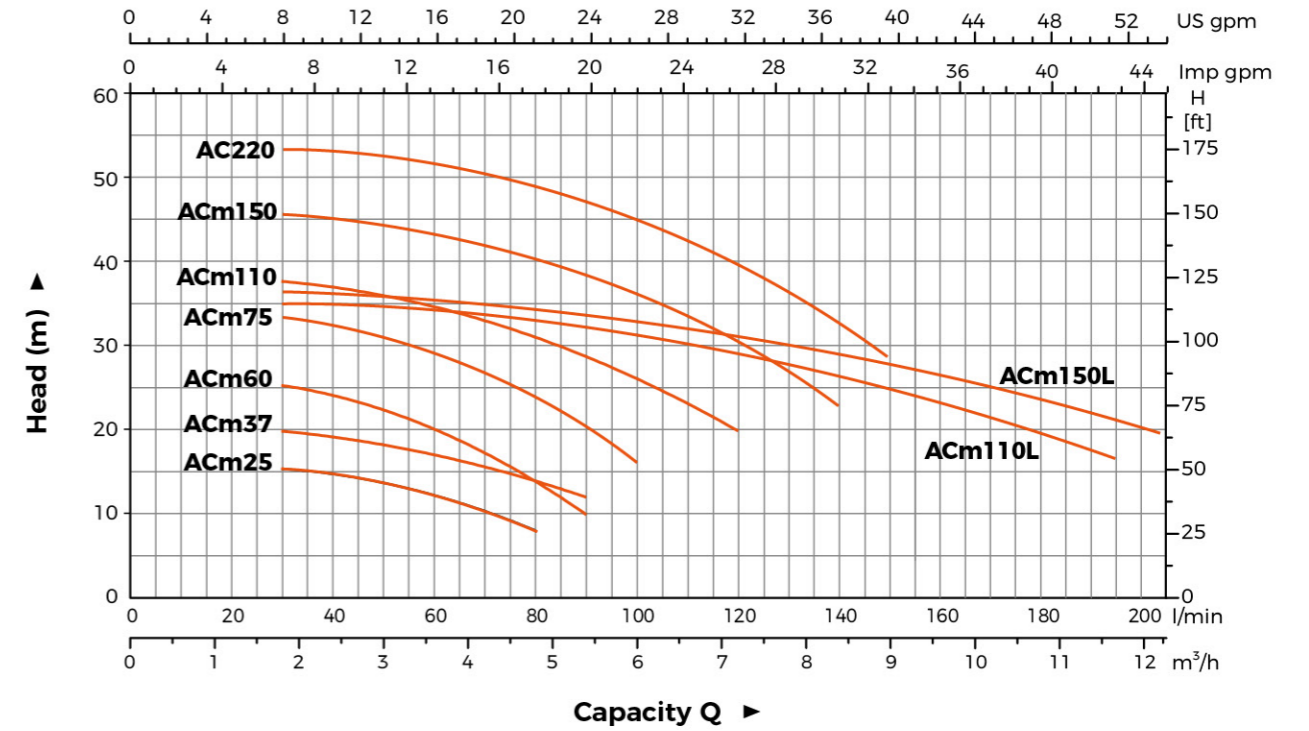

Material Table

No.	Part	Material	No.	Part	Material
1	Pump body	HT200	11	Cover box	PP-GF20
2	Impeller	HPb59-1	12	Wiring base assembly	PC
3	Mechanical seal		13	Bearing	
4	Supper cover	AISI304/HT200	14	Rotor	
5	Support	ADC12			
6	Fan cover	PP			
7	Fan	PP-GF10			
8	End plate	ADC12			
9	Stator				
10	Capacitor				

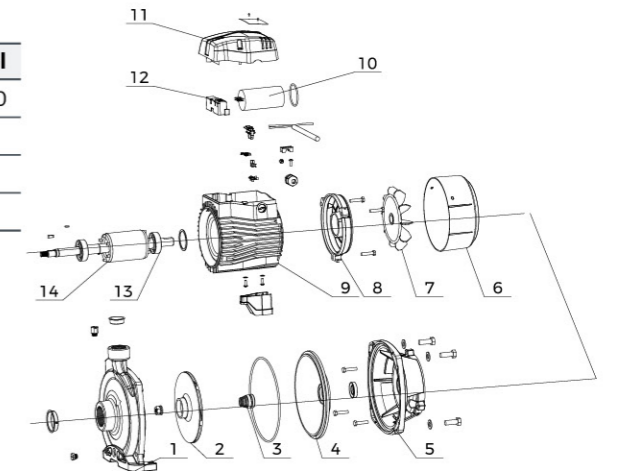

Package Information

Model	CW (Kgs)	L (mm)	W (mm)	H (mm)	Quantity (PCS/20'TEU)
ACm25	8.3	290	185	239	2124
ACm37	8.8	290	185	239	2124
ACm60	11.3	333	215	274	1384
ACm75	13.4	333	215	274	1384
ACm110	18	383	233	301	987
ACm150	22	425	265	324	770
AC220	23.3	425	265	310	770
ACm110L	18.6	383	233	287	987
ACm150L	19.5	383	233	287	987

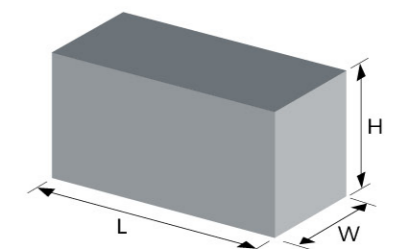

ACm
Centrifugal Pump



Application

- Can be used to transfer clean water or other liquids similar to water in physical and chemical properties
- Suitable for industrial use and urban water supply, pressure boosting for high buildings and fire fighting, garden irrigation, long-distance water transfer, heating ventilation and air conditioning, circulation and pressure boosting for cold and hot water, and supporting equipment etc.

Pump

- Cast iron pump body and support under special anti-rust treatment
- AISI 304 shaft
- Max. liquid temperature: +60°C
- Max. suction: +8 m

Motor

- Low noise & Long life bearing
- Motor with copper winding
- Insulation class: F
- Enclosures class: IPX4
- Max. ambient temperature: +50°C
- IE2 motor
(Three phase, power ≥ 0.75kW, AC750C2 and AC750C4 excluded)

Identification Codes

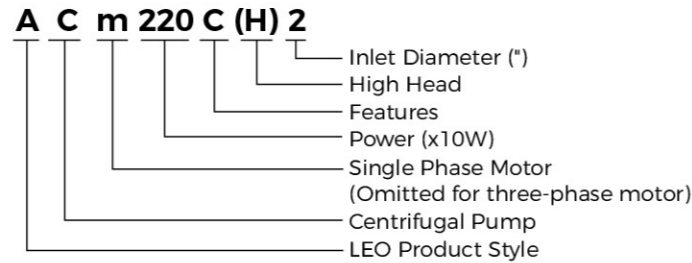

Technical Data

Model		Power		Q(m³/h)		Q(l/min)																										
Single Phase	Three Phase	kW	HP	0	6	9	12	15	18	24	27	30	36	42	48	54	0	100	150	200	250	300	400	450	500	600	700	800	900			
ACm220CH2	AC220CH2	2.2	3	H (m)	31	30	29.5	28.5	27.5	26	21.5	18.5	-	-	-	-	31	30	29.5	28.5	27.5	26	21.5	18.5	-	-	-	-	-			
ACm300CH2	AC300CH2	3	4		38	37.5	37	36	34.5	33	28.5	25.5	-	-	-	-	38	37.5	37	36	34.5	33	28.5	25.5	-	-	-	-	-	-		
ACm400CH2	AC400CH2	4	5.5		49	48	47	46	45	43.5	39.5	37	-	-	-	-	49	48	47	46	45	43.5	39.5	37	-	-	-	-	-	-	-	
-	AC550CH2	5.5	7.5		54	52.5	52	51	50	49	46	44	42	-	-	-	54	52.5	52	51	50	49	46	44	42	-	-	-	-	-	-	
ACm300C2	AC300C2	3	4		30	29.5	29	28.5	28	27	25	23.5	22	19.5	15.5	11.5	-	30	29.5	29	28.5	28	27	25	23.5	22	19.5	15.5	11.5	-	-	
ACm400C2	AC400C2	4	5.5		39	38.5	38	37.5	37	36	34	32.5	31	28	24	18.5	13	39	38.5	38	37.5	37	36	34	32.5	31	28	24	18.5	13	-	-
-	AC550C2	5.5	7.5		46.5	45.5	45	44.5	43.5	42.5	40	38.5	37	33	28	22	15	46.5	45.5	45	44.5	43.5	42.5	40	38.5	37	33	28	22	15	-	-
-	AC750C2	7.5	10		56.5	55	55	54.5	53.5	52.5	50	48.5	46.5	42	36.5	30.5	20	56.5	55	55	54.5	53.5	52.5	50	48.5	46.5	42	36.5	30.5	20	-	-
-	AC750C4	7.5	10		52.5	52	52	51.5	51	50.5	48	46.5	44.5	40	35.5	30.5	24	52.5	52	52	51.5	51	50.5	48	46.5	44.5	40	35.5	30.5	24	-	-

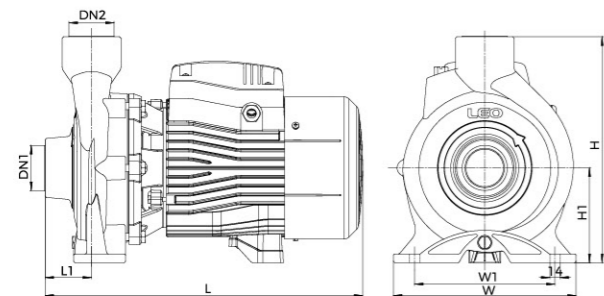

Dimension

Model	DN1	DN2	L (mm)	W (mm)	H (mm)	L1 (mm)	W1 (mm)	H1 (mm)
AC(m)220CH2	2"	2"	445	255	316	66	186	132
AC(m)300CH2			445	255	316	66	186	132
AC(m)400CH2			499	280	327	71	216	136
AC550CH2			499	280	327	71	216	136
AC(m)300C2			445	255	316	66	186	132
AC(m)400C2			499	280	327	71	216	136
AC550C2	4"	3"	499	280	327	71	216	136
AC750C2			515	290	361	86	216	150
AC750C4			525	290	361	96	216	150

Hydraulic Performance Curves

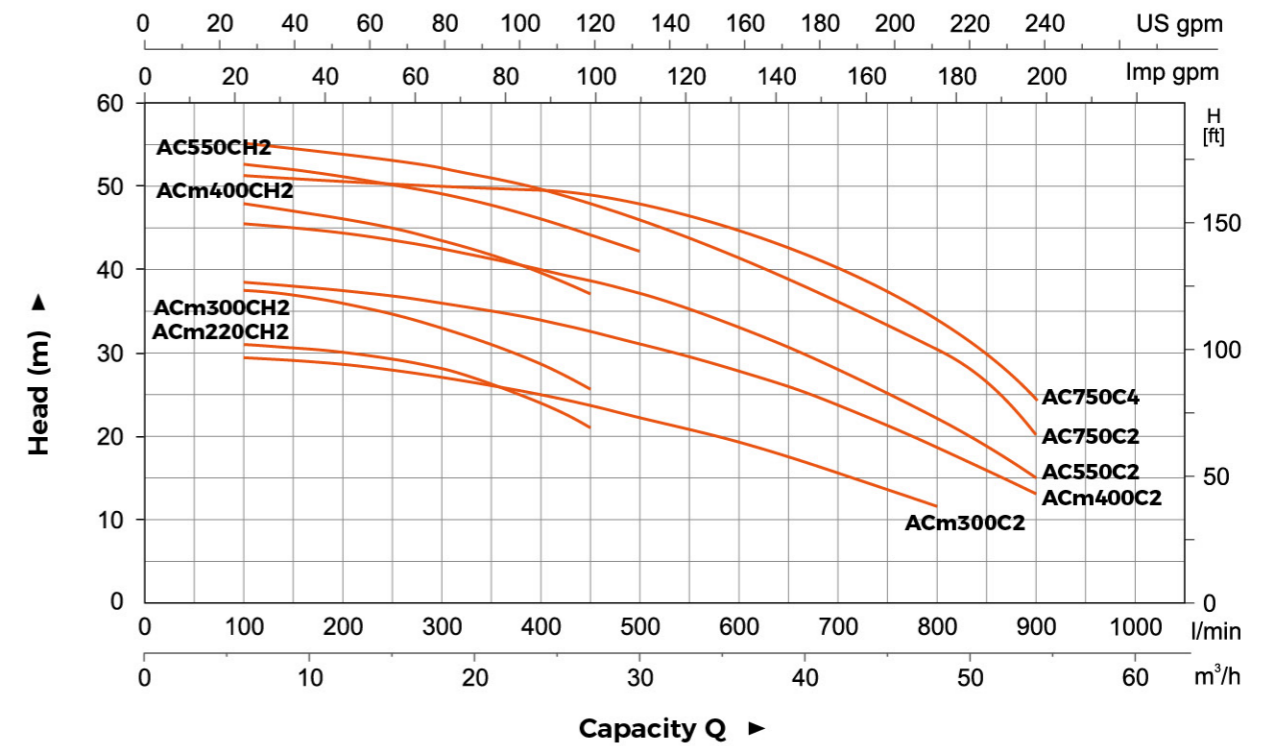

Material Table

No.	Part	Material	No.	Part	Material
1	Pump body	HT200	10	Capacitor	
2	Impeller	HPb59-1	11	Cover box	PP-GF20
3	Mechanical seal		12	Rotor	
4	Bracket cover	HT200	13	Bearing	
5	Bracket	ADC12			
6	Fan cover	PP			
7	Fan	PP-GF10			
8	End plate	ADC12			
9	Stator				

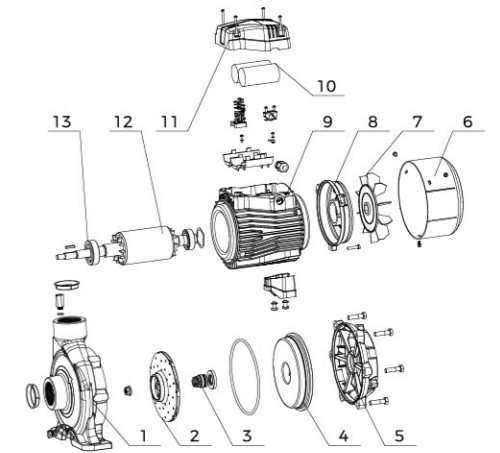

Package Information

Model	GW (Kgs)	L (mm)	W (mm)	H (mm)	Quantity (PCS/20'TEU)
AC(m)220CH2	39.1	507	304	372	486
AC(m)300CH2	41.8	507	304	372	478
AC(m)400CH2	56.5	562	328	383	345
AC550CH2	57.1	562	328	383	345
AC(m)300C2	41.6	507	304	372	483
AC(m)400C2	57.5	562	328	383	345
AC550C2	55.5	562	328	383	345
AC750C2	62	587	338	417	305
AC750C4	63.7	587	338	417	305

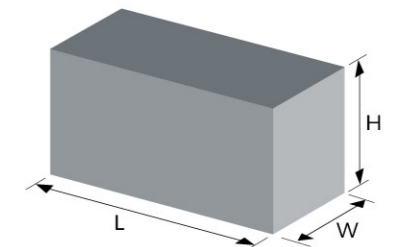

ACm
Centrifugal Pump



Application

- Can be used to transfer clean water or other liquids similar to water in physical and chemical properties
- Suitable for industrial use and urban water supply, pressure boosting for high buildings and fire fighting, garden irrigation, long-distance water transfer, heating ventilation and air conditioning, circulation and pressure boosting for cold and hot water, and supporting equipment etc.

Pump

- Cast iron pump body and support under special anti-rust treatment
- AISI 304 shaft
- Max. liquid temperature: +60°C
- Max. suction: +8 m

Motor

- Low noise & Long life bearing
- Motor with copper winding
- Built-in thermal protector for single phase motor
- Insulation class: F
- Enclosures class: IPX4
- Max. ambient temperature: +50°C
- IE 2 motor (Three phase, power ≥ 0.75kW)

Identification Codes

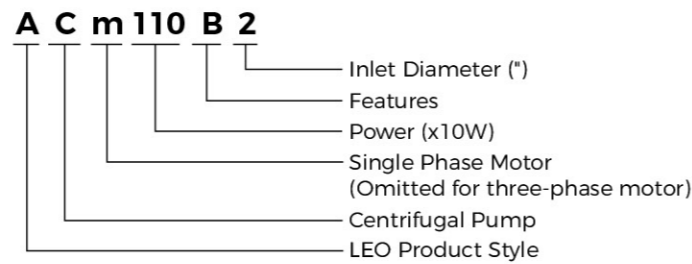

Technical Data

Model		Power		Q(m³/h)	Q(l/min)										
Single Phase	Three Phase	kW	HP		0	6	9	12	15	18	21	24	30		
ACm60B2	AC60B2	0.6	0.8	H (m)	12.5	12	11.7	11	10.2	9.2	8	6.5	-		
ACm75B2	AC75B2	0.75	1		14	13.7	13.5	13	12.3	11.2	9.9	8.5	5.5		
ACm110B2	AC110B2	1.1	1.5		19.5	19.2	19	18.5	17.7	16.5	15	13	8.5		
ACm150B2	AC150B2	1.5	2		22	21.5	21	20.5	19.5	18.3	16.5	14.5	9.5		

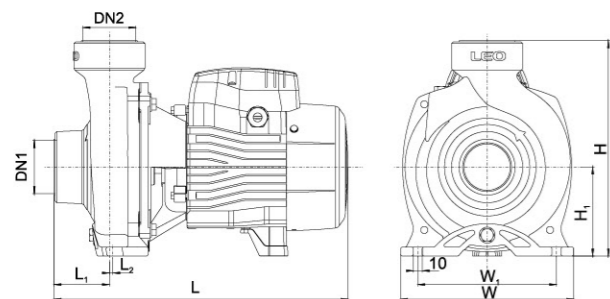

Dimension

Model	DN1	DN2	L (mm)	W (mm)	H (mm)	L1 (mm)	L2 (mm)	W1 (mm)	H1 (mm)
AC(m)60B2	2"	2"	336	195	240	62.5	4	156	100
AC(m)75B2			336	195	240	62.5	4	156	100
AC(m)110B2			378	206	263	59	3.5	166	112
AC(m)150B2			378	206	263	59	3.5	166	112

Hydraulic Performance Curves

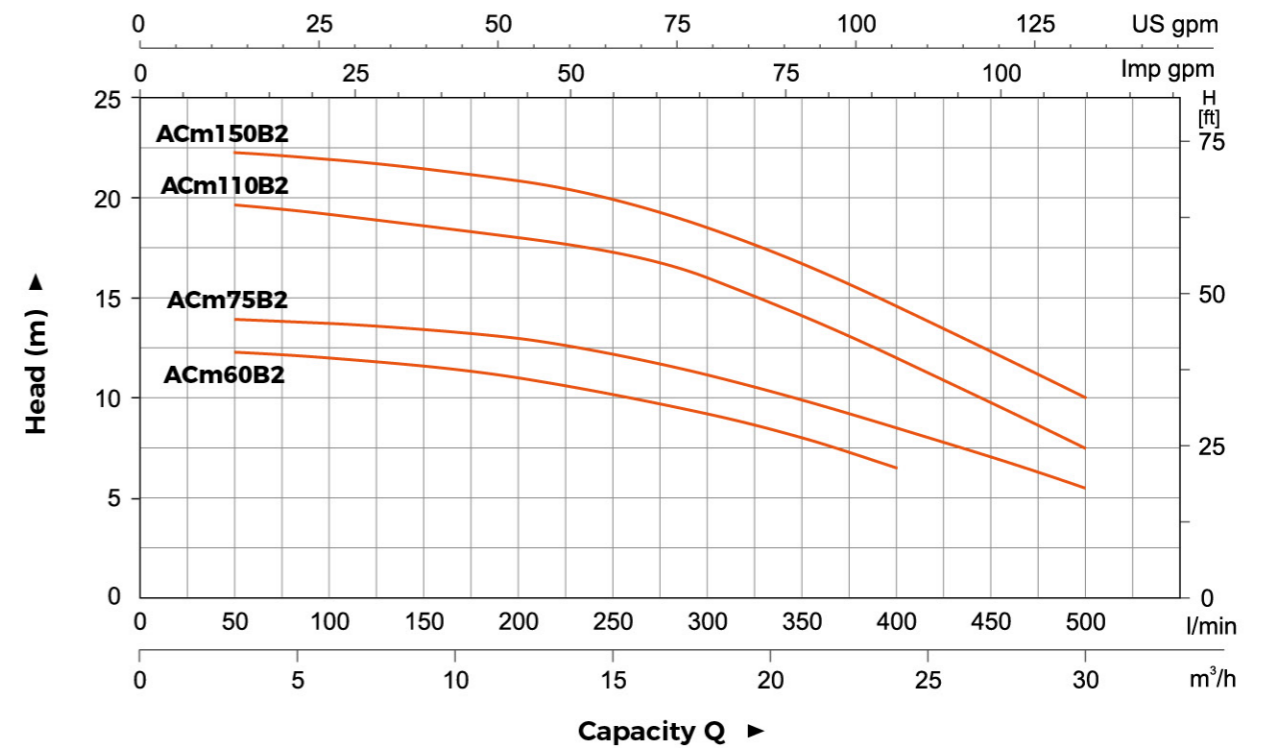

Material Table

No.	Part	Material	No.	Part	Material
1	Pump body	HT200	10	Capacitor	
2	Impeller	HPb59-1	11	Cover box	PP-GF20
3	Mechanical seal		12	Wiring base assembly	PC
4	Bracket cover	HT200	13	Deep groove ball bearing	
5	Bracket	ADC12	14	Rotor	
6	Fan cover	PP			
7	Fan	PP-GF10			
8	End plate	ADC12			
9	Stator				

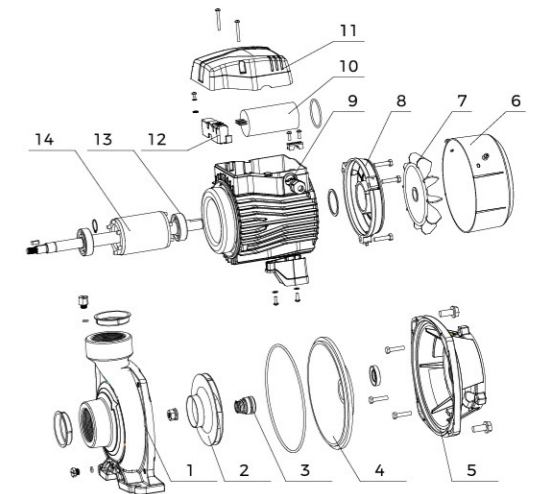

Package Information

Model	GW (Kgs)	L (mm)	W (mm)	H (mm)	Quantity (PCS/20'TEU)
AC(m)60B2	13.1	375	214	265	1264
AC(m)75B2	14.2	375	214	265	1264
AC(m)110B2	19.9	415	255	285	945
AC(m)150B2	20.7	415	255	285	945

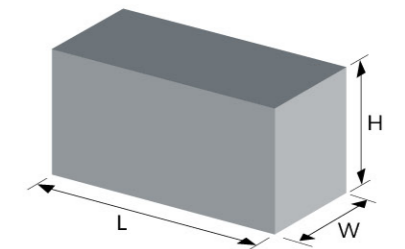

ACm
Centrifugal Pump



Application

- Can be used to transfer clean water or other liquids similar to water in physical and chemical properties
- Suitable for industrial use and urban water supply, pressure boosting for high buildings and fire fighting, garden irrigation, long-distance water transfer, heating ventilation and air conditioning, circulation and pressure boosting for cold and hot water, and supporting equipment etc.

Pump

- Cast iron pump body and support under special anti-rust treatment
- AISI304 welding shaft
- Max. liquid temperature: +60°C
- Max.suction: + 8m

Motor

- Low noise&Long life bearing
- Motor with copper winding
- Built-in thermal protector
- Insulation class: F
- Enclosures class: IPX4
- Max. ambient temperature: +50°C
- S1 Duty

Identification Codes

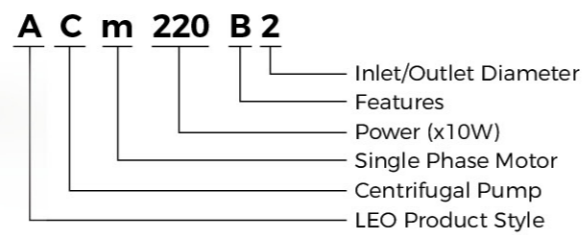

Technical Data

Model	Power		Q(m ³ /h)	Q(l/min)										
	kW	HP		0	6	12	18	19	24	30	36	38.9		
ACm220B2	2.2	3.0	H(m)	0	100	200	300	316.7	400	500	600	648.3		
				23.9	23.8	22.7	21.1	20.9	18.6	15.2	10.1	8.2		

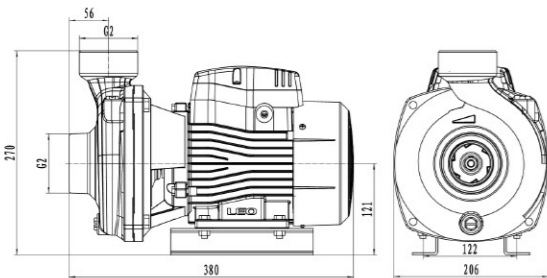

Dimension

Model	DN1	DN2	L (mm)	W (mm)	H (mm)	W1 (mm)	H1 (mm)
ACm220B2	2"	2"	380	206	270	122	121

Hydraulic Performance Curves

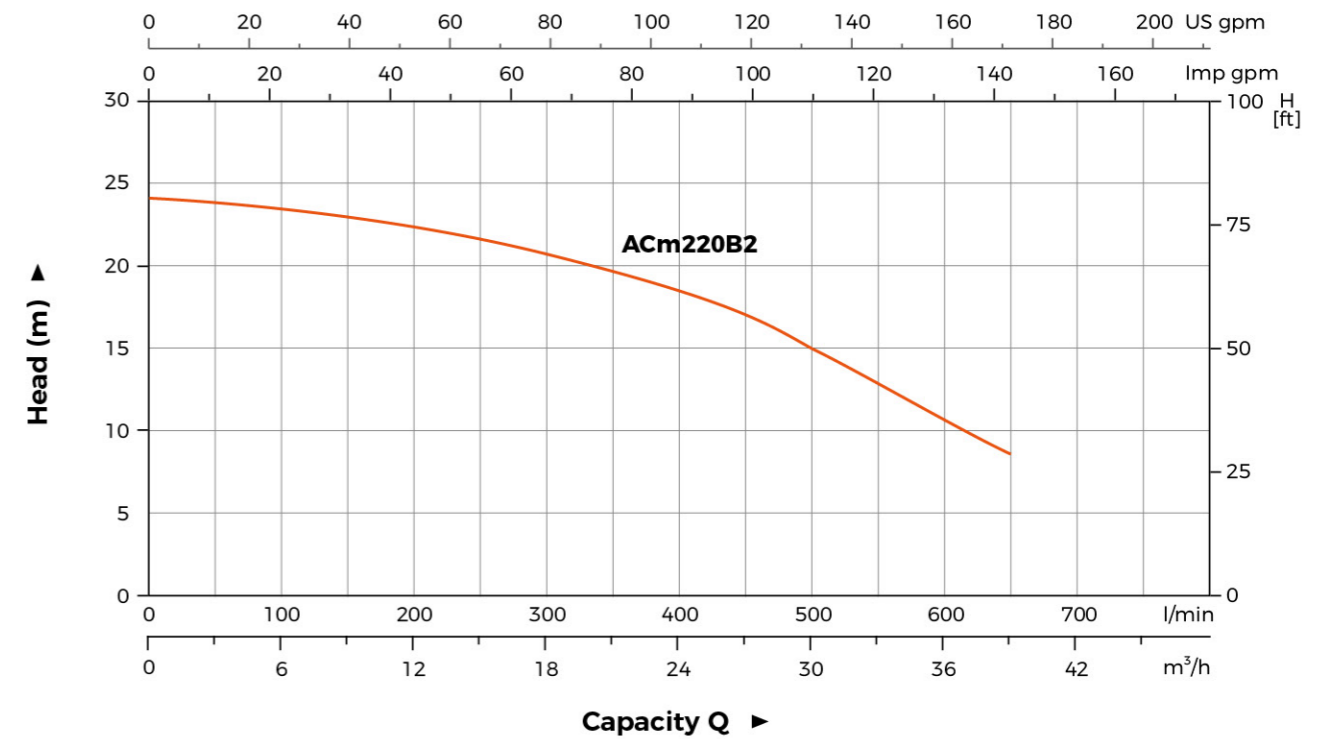

Material Table

No.	Part	Material	No.	Part	Material
1	Pump body	HT200	12	Capacitor	ZL102
2	Impeller	HPb59-1	13	Deep groove ball bearing	65Mn
3	Mechanical seal		14	Rotor	
4	Bracket cover	HT200	15	Support foot	
5	Bracket	ADC12			
6	Fan cover	PP			
7	Fan	PP-GF10			
8	End plate	ADC12			
9	Stator				
10	Cover box	PP-GF20			
11	Wiring base assembly	PC			

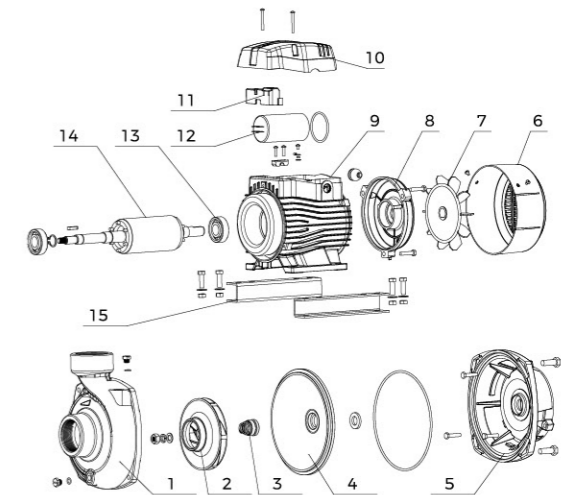

Package Information

Model	GW (Kgs)	L (mm)	W (mm)	H (mm)	Quantity (PCS/20'TEU)
ACm220B2	23	416	248	286	819

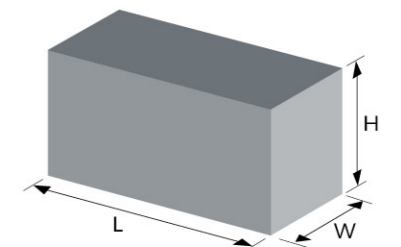

ACm
Centrifugal Pump



Application

- Can be used to transfer clean water or other liquids similar to water in physical and chemical properties
- Suitable for industrial use and urban water supply, pressure boosting for high buildings and fire fighting, garden irrigation, long-distance water transfer, heating ventilation and air conditioning, circulation and pressure boosting for cold and hot water, and supporting equipment etc.

Pump

- Cast iron pump body and support under special anti-rust treatment
- AISI 304 shaft
- Max. liquid temperature: +60°C
- Max.suction: + 8m

Motor

- Low noise&Long life bearing
- Motor with copper winding
- Built-in thermal protector for single phase motor (≤1.5kW)
- Insulation class: F
- Enclosures class: IPX4
- Max. ambient temperature: +50°C
- IE 2 motor (Three phase, power ≥ 0.75kW)

Identification Codes

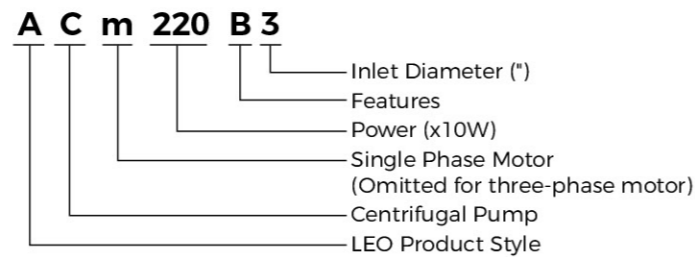

Technical Data

Model		Power		Q(m³/h)																									
Single Phase	Three Phase	kW	HP	0	12	18	24	30	36	42	48	54	60	66	71	Q(l/min)													
				0	200	300	400	500	600	700	800	900	1000	1100	1200	H (m)													
ACm110B3	AC110B3	1.1	1.5	12.5	12.5	12.1	11.5	10.5	9.5	8.4	7.1	5.5	-	-	-	12.5	12.5	12.1	11.5	10.5	9.5	8.4	7.1	5.5	-	-	-		
ACm110B4	AC110B4	1.1	1.5	14.5	14.3	14	13.5	12.8	12	11.2	9.9	8.4	6	-	-	14.5	14.3	14	13.5	12.8	12	11.2	9.9	8.4	6	-	-		
ACm150B3	AC150B3	1.5	2	17.5	17.3	17.1	16.5	16	15.2	14.2	13.2	11.7	10	7.2	-	17.5	17.3	17.1	16.5	16	15.2	14.2	13.2	11.7	10	7.2	-		
ACm150B4	AC150B4	1.5	2	20	19.8	19.6	19.5	19	18.3	17.5	16.2	14.6	13	11.5	10	20	19.8	19.6	19.5	19	18.3	17.5	16.2	14.6	13	11.5	10		
ACm220B3	AC220B3	2.2	3	20	19.8	19.6	19.5	19	18.3	17.5	16.2	14.6	13	11.5	10	20	19.8	19.6	19.5	19	18.3	17.5	16.2	14.6	13	11.5	10		
ACm220B4	AC220B4	2.2	3	20	19.8	19.6	19.5	19	18.3	17.5	16.2	14.6	13	11.5	10	20	19.8	19.6	19.5	19	18.3	17.5	16.2	14.6	13	11.5	10		
ACm300B3	AC300B3	3	4	20	19.8	19.6	19.5	19	18.3	17.5	16.2	14.6	13	11.5	10	20	19.8	19.6	19.5	19	18.3	17.5	16.2	14.6	13	11.5	10		
ACm300B4	AC300B4	3	4	20	19.8	19.6	19.5	19	18.3	17.5	16.2	14.6	13	11.5	10	20	19.8	19.6	19.5	19	18.3	17.5	16.2	14.6	13	11.5	10		

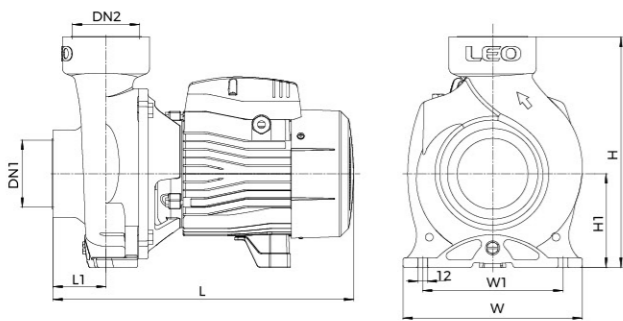

Dimension

Model	DN1	DN2	L (mm)	W (mm)	H (mm)	L1 (mm)	W1 (mm)	H1 (mm)
AC(m)110B3	3"	3"	385	230	296	69	180	120
AC(m)110B4	4"	4"	392	230	296	76	180	120
AC(m)150B3	3"	3"	385	230	296	69	180	120
AC(m)150B4	4"	4"	392	230	296	76	180	120
AC(m)220B3	3"	3"	455	230	296	69	180	120
AC(m)220B4	4"	4"	462	230	296	76	180	120
AC(m)300B3	3"	3"	455	230	296	69	180	120
AC(m)300B4	4"	4"	462	230	296	76	180	120

Hydraulic Performance Curves

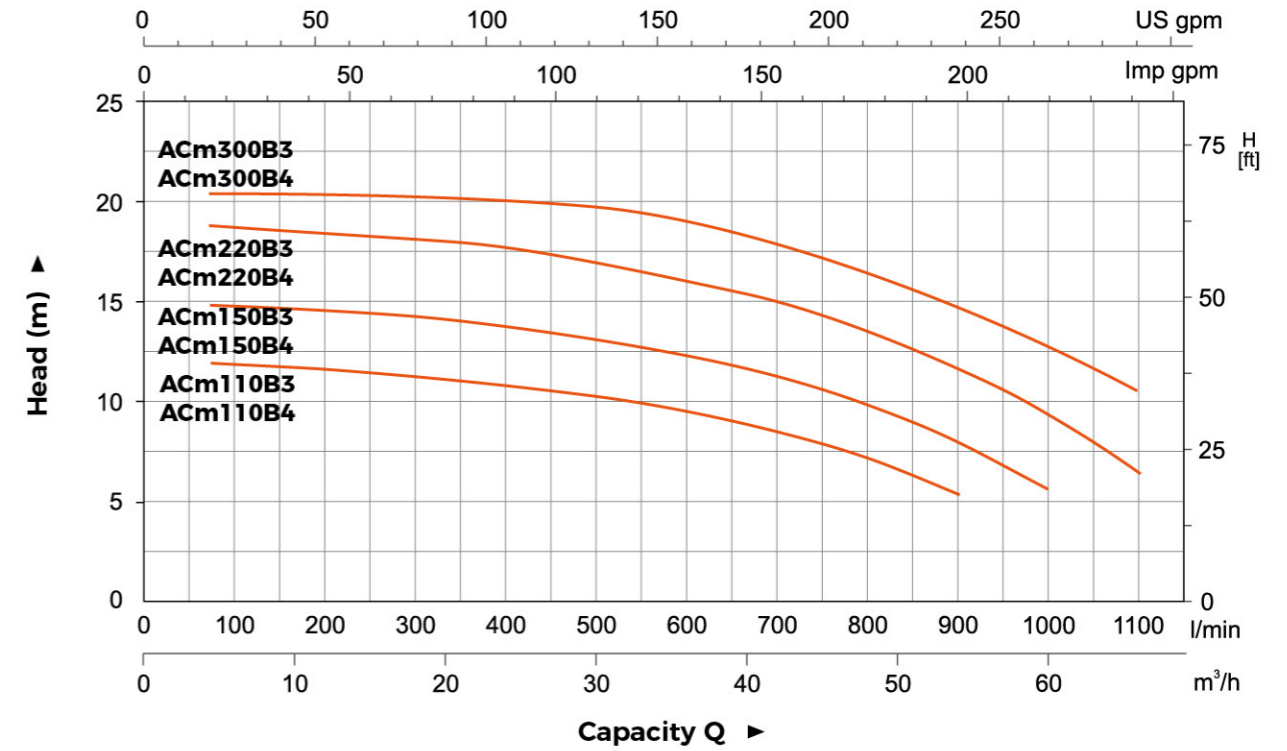

Material Table

No.	Part	Material	No.	Part	Material
1	Pump body	HT200	11	Stator	
2	Impeller	HPb59-1	12	Rotor	
3	Mechanical seal		13	Deep groove ball bearing	
4	Bracket cover	HT200			
5	Bracket	HT200			
6	Fan cover	PP			
7	Fan	PP-GF10			
8	End plate	ADC12			
9	Capacitor				
10	Cover box	ABS			

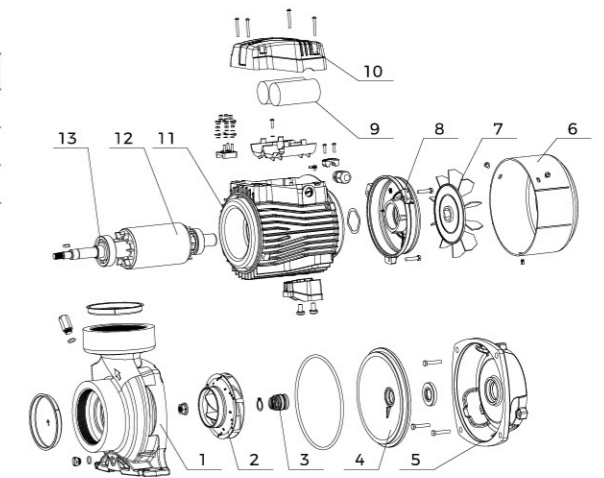

Package Information

Model	GW (Kgs)	L (mm)	W (mm)	H (mm)	Quantity (PCS/20'TEU)
AC(m)110B3	26.3	433	255	332	684
AC(m)110B4	29.5	433	255	332	675
AC(m)150B3	27.2	433	255	332	684
AC(m)150B4	30.4	433	255	332	655
AC(m)220B3	36.5	522	288	352	510
AC(m)220B4	40.8	522	288	352	496
AC(m)300B3	39.8	522	288	352	506
AC(m)300B4	43.3	522	288	352	467

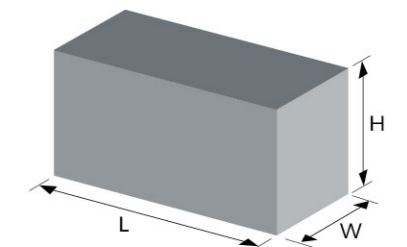

ACm
Centrifugal Pump



Application

- Can be used to transfer clean water or other liquids similar to water in physical and chemical properties
- Suitable for industrial use and urban water supply, pressure boosting for high buildings and fire fighting, garden irrigation, long-distance water transfer, heating ventilation and air conditioning, circulation and pressure boosting for cold and hot water, and supporting equipment etc.

Pump

- Cast iron pump body and support under special anti-rust treatment
- AISI 304 shaft
- Max. liquid temperature: +60°C
- Max.suction: + 8m

Motor

- Low noise&Long life bearing
- Motor with copper winding
- Built-in thermal protector for single phase motor ($\leq 1.5kW$)
- Insulation class: F
- Enclosures class: IPX4
- Max. ambient temperature: +50°C
- IE 2 motor (Three phase, power $\geq 0.75kW$)

Identification Codes

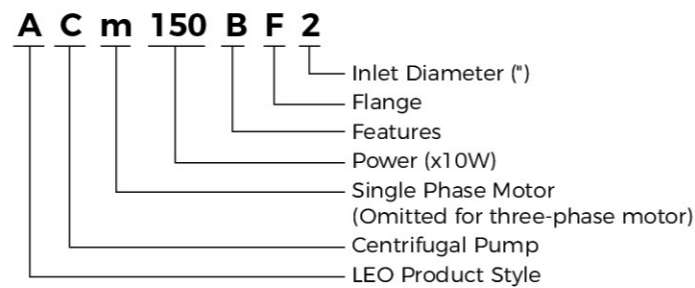

Technical Data

Model		Power		Q(m ³ /h)	0	12	18	24	30	36	42	48	54	60	66	72	84	96
Single Phase	Three Phase	kW	HP	Q(l/min)	0	200	300	400	500	600	700	800	900	1000	1100	1200	1400	1600
ACm110BF2	AC110BF2	1.1	1.5	H (m)	19.5	18.5	16.5	13	8.5	-	-	-	-	-	-	-	-	-
ACm110BF3	AC110BF3	1.1	1.5		12.5	12.5	21.1	11.5	10.5	9.5	8.4	7.1	5.5	-	-	-	-	-
ACm150BF2	AC150BF2	1.5	2		22	20.5	18.3	14.5	9.5	-	-	-	-	-	-	-	-	-
ACm150BF3	AC150BF3	1.5	2		14.5	14.3	14	13.5	12.8	12	11.2	9.9	8.4	6	-	-	-	-
ACm220BF3	AC220BF3	2.2	3		17.5	17.3	17.1	16.5	16	15.2	14.2	13.2	11.7	10	7.2	-	-	-
ACm400BF4	AC400BF4	4	5.5		16.5	-	-	16	15.8	15.5	15.3	15.3	15	14.7	14.4	14	13.2	12.1

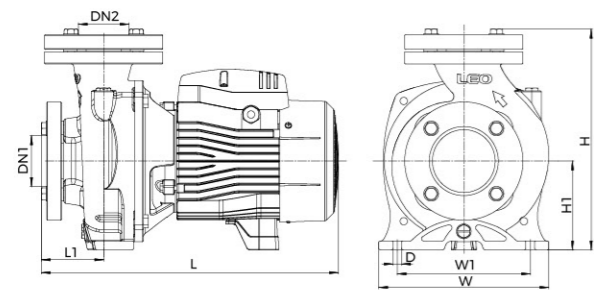

Dimension

Model	DN1	DN2	L (mm)	W (mm)	H (mm)	L1 (mm)	W1 (mm)	H1 (mm)	D (mm)
AC(m)110BF2	2"	2"	389	206	268	63	166	112	10
AC(m)110BF3	3"	3"	400	230	298	84	180	120	12
AC(m)150BF2	2"	2"	389	206	267	63	166	112	10
AC(m)150BF3	3"	3"	400	230	298	84	180	120	12
AC(m)220BF3	3"	3"	470	230	298	84	180	120	12
AC(m)400BF4	4"	4"	565	281	400	117	206	160	16

Hydraulic Performance Curves

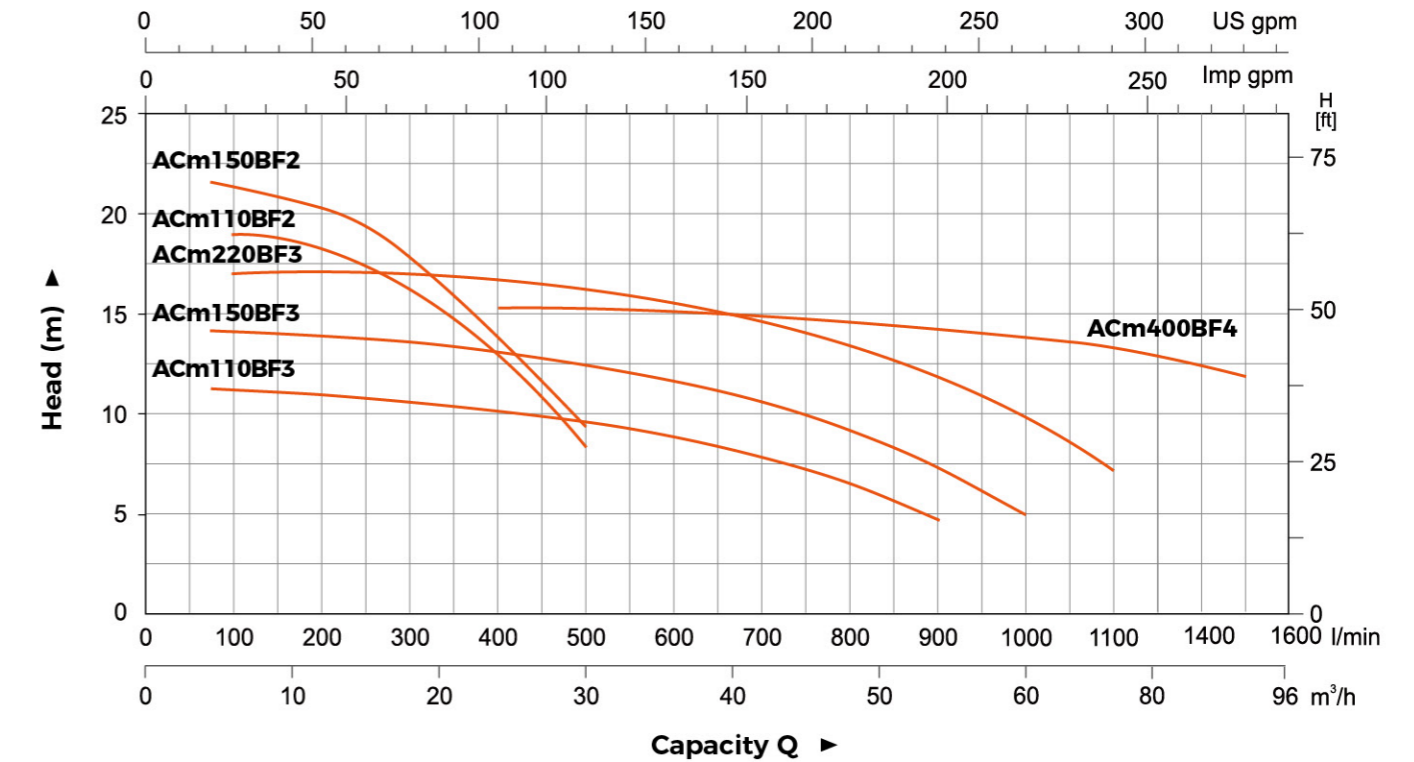

Material Table

No.	Part	Material	No.	Part	Material
1	Pump body	HT200	11	Wiring base assembly	PC
2	Impeller	HPb59-1	12	Capacitor	
3	Mechanical seal		13	Deep groove ball bearing	
4	Bracket cover	HT200	14	Rotor	
5	Bracket	ADC12	15	Flange	HT200
6	Fan cover	PP			
7	Fan	PP-GF 10			
8	End plate	ADC12			
9	Stator				
10	Cover box	PP-GF20			

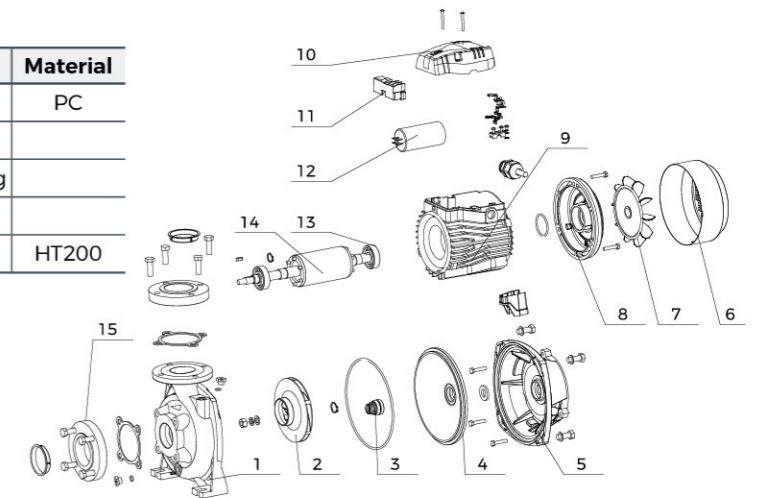

Package Information

Model	GW (Kgs)	L (mm)	W (mm)	H (mm)	Quantity (PCS/20'TEU)
AC(m)110BF2	22.2	414	230	300	900
AC(m)110BF3	24	414	230	300	833
AC(m)150BF2	31.5	433	255	332	634
AC(m)150BF3	32.5	433	255	332	615
AC(m)220BF3	41.7	522	288	352	500
AC(m)400BF4	72.8	658	330	457	204

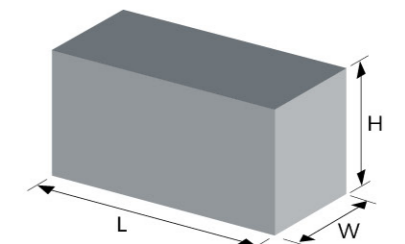

Accessories

Identification Codes

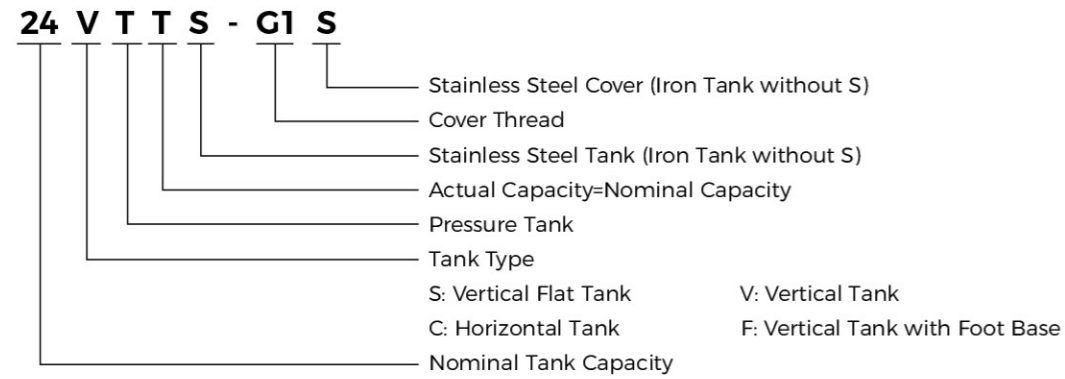

Tank



Model	Max. Pressure (bar)	Nominal Capacity (L)	Actual Capacity (L)	Membrane	Max. Temp (°C)	Connection
24ST	8	24	20	Epdm	60	G1"
24STT	8	24	24	Epdm	60	G1"



Model	Max. Pressure (bar)	Nominal Capacity (L)	Actual Capacity (L)	Membrane	Max. Temp (°C)	Connection
2VT	8	2	2	Epdm	60	G1/2"
4VT	8	4	4	Epdm	60	G1"
5VT	8	5	5	Epdm	60	G1"
8VT	8	8	8	Epdm	60	G1"
19VT	8	19	18	Epdm	60	G1"
24VT	8	24	20	Epdm	60	G1"
24VTT	8	24	24	Epdm	60	G1"



Model	Max. Pressure (bar)	Nominal Capacity (L)	Actual Capacity (L)	Membrane	Max. Temp (°C)	Connection
19CT	8	19	18	Epdm	60	G1"
24CT	8	24	20	Epdm	60	G1"
24CTT	8	24	24	Epdm	60	G1"

*For capacity < 50L, pressure gauge is optional.
For capacity ≥ 50L, pressure gauge is standard.

Tank



Model	Max. Pressure (bar)	Nominal Capacity (L)	Actual Capacity (L)	Membrane	Max. Temp (°C)	Connection
50CT	8	50	36	Epdm	60	G1"
50CTT	8	50	50	Epdm	60	G1"
60CTT	8	60	60	Epdm	60	G1"
100CT	8	100	80	Epdm	60	G1"
100CTT	8	100	100	Epdm	60	G1"



Model	Max. Pressure (bar)	Nominal Capacity (L)	Actual Capacity (L)	Membrane	Max. Temp (°C)	Connection
50FT	8	50	36	Epdm	60	G1"
50FTT	8	50	50	Epdm	60	G1"
60FTT	8	60	60	Epdm	60	G1"
100FT	8	100	80	Epdm	60	G1"
100FTT	8	100	100	Epdm	60	G1"
200FTT	8	200	200	Butyl	60	G1½"
300FTT	8	300	300	Butyl	60	G1½"
500FTT	8	500	500	Butyl	60	G1½"

*For capacity < 50L, pressure gauge is optional.
For capacity ≥ 50L, pressure gauge is standard.

3-Way / 5-Way



Model	Connection	Length
3TA	G1"	70 , 80
5TA	G1"	80 , 90
5TB	G1"	80 , 90

Foot Valve



FVA

Model	Connection
FVA1	1"
FVA1.25	1¼"
FVA1.5	1½"
FVA2	2"
FVA3	3"

- Stainless Steel mesh
- Can be used as a check valve

Accessories

Flexible Hose



Model	FH12.8-01(L=128mm)	FH44-03(L=440mm)
Inlet	G3/4"	G1"
Outlet	G3/8"	G1"
Material	Stainless steel wire	
Operating Limits	Fluid temperature up to 35°C Max. ambient temperature 40°C	

Filter



Model	WF-01B	WF-02B
Inlet/Outlet	1" x 1"	1" x 1"
Capacity	1L	2L
Max. Pressure	5 bar	5 bar
Operating Limits	Fluid temperature up to 35°C Max. ambient temperature 40°C	

Pressure Gauge



Axial

Radial

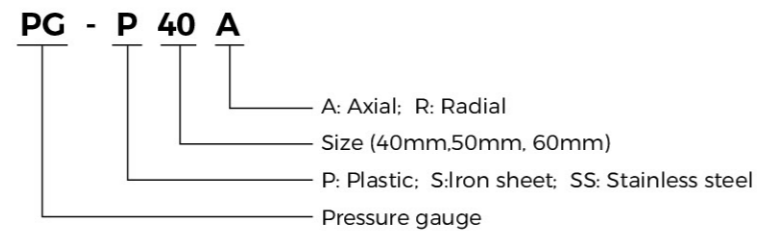

- Two connection types: (1) G1/4" (2) M10x1
- For 40mm gauge, the scale: 0 - 6 bar
- For 50mm gauge, the scale: 0 - 10 bar or 0 - 6 bar
- Back/bottom connection

Automatic Pump Controller



PS-04A

Rated Voltage	110-120VAC	220-240VAC	110-240VAC
Rated Frequency	50-60Hz		
Max. Current	10(6)A		
Max. Power(P1)	0.55kW(110-120VAC)	1.1kW(220-240VAC)	
Starting Pressure	1.0bar, 1.5bar, 2.2bar		
Max. Working Pressure	10bar		
Screw Size	R1", NPT1", G1", G1-1/4", G1-1/2"		
Protection Class	IP65		
Max. Working Temperature	60 °C		



PS-04B

Rated Voltage	110-120VAC	220-240VAC	110-240VAC
Rated Frequency	50-60Hz		
Max. Current	10(6)A		
Max. Power(P1)	0.55kW(110-120VAC)	1.1kW(220-240VAC)	
Starting Pressure	1.2bar, 1.5bar, 2.2bar		
Max. Working Pressure	10bar		
Screw Size	R1"		
Protection Class	IP65		
Max. Working Temperature	60 °C		



PS-04C

Rated Voltage	110-120VAC	220-240VAC	110-240VAC
Rated Frequency	50-60Hz		
Max. Current	10(6)A		
Max. Power(P1)	0.55kW(110-120VAC)	1.1kW(220-240VAC)	
Starting Pressure	1.2bar, 1.5bar, 2.2bar		
Max. Working Pressure	10bar		
Screw Size	G1"		
Protection Class	IP54		
Max. Working Temperature	60 °C		

* 1bar=14.50PSI

Accessories

Automatic Pump Controller



PS-04D

Rated Voltage	110-240VAC	220-240VAC	380VAC
Rated Frequency	50-60Hz		
Max. Current	30(16)A		
Max. Power(P1)	1.1kW	2.2kW	4.0kW
Starting Pressure	1.2bar, 1.5bar, 2.2bar		
Max. Working Pressure	10bar		
Screw Size	G1", G1-1/4", G1-1/2", NPT1"		G1-1/2"
Protection Class	IP65		
Max. Working Temperature	60 °C		



PS-04E

Rated Voltage	110-120VAC	220-240VAC	110-240VAC
Rated Frequency	50-60Hz		
Max. Current	30(16)A		
Max. Power(P1)	1.1kW(110-120VAC)	2.2kW(220-240VAC)	
Starting Pressure	0.8bar - 6.7bar		
Max. Working Pressure	8bar		
Screw Size	G1"		
Protection Class	IP65		
Max. Working Temperature	60 °C		



PS-04E-1

Rated Voltage	110-120VAC	220-240VAC	110-240VAC
Rated Frequency	50-60Hz		
Max. Current	30(16)A		
Max. Power(P1)	1.1kW(110-120VAC)	2.2kW(220-240VAC)	
Starting Pressure	1.5bar, 2.2bar		
Max. Working Pressure	8bar		
Screw Size	G1"		
Protection Class	IP65		
Max. Working Temperature	60 °C		

* 1bar=14.50PSI

Automatic Pump Controller



PS-04T

Rated Voltage	110-120VAC	220-240VAC	110-240VAC
Rated Frequency	50-60Hz		
Max. Current	10(6)A		
Max. Power(P1)	0.55kW(110-120VAC)	1.1kW(220-240VAC)	
Starting Pressure	1.2 - 2.5bar		
Max. Working Pressure	10bar		
Screw Size	G1"		
Protection Class	IP65		
Max. Working Temperature	60 °C		



PS-04F

Rated Voltage	220-240V		
Rated Frequency	50-60Hz		
Max. Current	16(10)A		
Max. Power(P1)	1.8kW(220-240VAC)		
Starting Pressure	0.5-3bar		
Max. Working Pressure	10bar		
Screw Size	G1"		
Protection Class	IP65		
Max. Working Temperature	60 °C		

Pressure Switch



PS-02A

Rated Voltage	110-120VAC	220-240VAC
Frequency	50/60 Hz	
Max. Current	20A	12A
Max. Power(P1)	1.6kW	1.9kW
Min. Cut-in	1 bar	
Max. Cut-out	7bar	
Starting/Stopping Pressure	bar: 1.0/2.1; 1.4/2.8; 2.1/3.5; 2.8/4.2; 3.5/4.9; 4.9/7.0	
Screw Size	Female: NPT1/4, ZG1/4 Male: NPT1/4, ZG1/4 Female revolving connector: G1/4, G3/8	
Protection Class	IP20	
Max. Working Temperature	60°C	

* Max. working pressure=Max. cut out*1.5

Accessories

Pressure Switch



PS-02B

Rated Voltage	110-120VAC	220-240VAC
Frequency	50/60 Hz	
Max. Current	20A	16A
Max. Power(P1)	1.6kW	2.6kW
Min. Cut-in	1bar	
Max. Cut-out	12bar	
Starting/Stopping Pressure	bar: 1.4/2.8; 2.1/3.5; 6.3/8.7; 9.6/12	
Screw Size	Female: NPT1/4, G1/4 Male: ZG1/4, M14 Female revolving connector: G1/4	
Protection Class	IP20	
Max. Working Temperature	60°C	



PS-02C

Rated Voltage	110-120VAC	220-240VAC	400VAC
Frequency	50/60 Hz		
Max. Current	16(8)A		
Max. Power(P1)	0.6kW	1.3kW	4.0kW
Min. Cut-in	1bar		
Max. Cut-out	5.5bar		
Starting/Stopping Pressure	bar: 1.2/2.4; 1.4/2.8; 1.5/3.0; 2.0/3.5; 3.5/4.9		
Screw Size	Female: NPT1/4, G1/4, Male: NPT1/4, G1/4, ZG1/4, Female revolving connector: G1/4, G3/8		
Protection Class	IP44		
Max. Working Temperature	60°C		



PS-02D

Rated Voltage	110-120VAC	220-240VAC
Frequency	50/60 Hz	
Max. Current	12A	
Max. Power(P1)	1.0kW	1.9kW
Min. Cut-in	1.4bar	
Max. Cut-out	6.9bar	
Starting/Stopping Pressure	bar: 1.4/2.8; 2.1/3.4; 2.8/4.1; 3.4/4.8	
Screw Size	Female: G1/4, Male: ZG1/4, G1/4, NPT1/4 Female revolving connector: G1/4, G3/8	
Protection Class	IP20	
Max. Working Temperature	60°C	

* Max. working pressure=Max. cut out*1.5

Capacitor



2 wires

2(4) terminals

Capacity(μF)	Type	Diameter(mm)	Length (mm)
6	2 wires	32	66
8	2 wires	32	66
8	4 terminals	35	72
10	2 wires	34	62
10	4 terminals	35	72
12	2 wires	40	73
16	2 wires	42	71
16	4 terminals	42	73
20	2 wires	42	74
20	4 terminals	42	74
25	2 wires	42	82
35	4 terminals	42	70
40	2 wires	42	82
40	4 terminals	45	73
42.5	2 terminals	51	100
45	2 terminals	51	100
50	2 terminals	51	100

Float Switch



FLO-01B

FLO-01B(With balance block)

Model	FLO-01B	FLO-01B(With balance block)
Specification	16(8)A 125/250V	
Cable	H07RN-F/8-F 3G1.0mm2x0.55m/0.65m/0.75m/2m/3m/5m/10m	
Lifetime	50000 cycles	
IP Protection	IP X8	
Operating Limits	Fluid temperature up to 35°C Max. ambient temperature 40°C	