



**GENERAL CATALOGUE**

 **PEDROLLO**<sup>®</sup>  
*... the spring of life*





### PERFORMANCE RANGE

- Flow rate up to **300 l/min** (18 m<sup>3</sup>/h)
- Head up to **14 m**

### APPLICATION LIMITS

- **5 m** maximum immersion depth
- Maximum liquid temperature **+40 °C**
- Passage of suspended solids up to **Ø 10 mm**
- Suction down to **21 mm** above ground level
- **180 mm** minimum immersion depth for continuous service

### CONSTRUCTION AND SAFETY STANDARDS

- Complete with **5 m** long power cable

EN 60335-1  
IEC 60335-1  
CEI 61-150

EN 60034-1  
IEC 60034-1  
CEI 2-3



### CERTIFICATIONS



### INSTALLATION AND USE

Designed to pump **clear or slightly dirty water**, these pumps are suitable for use in domestic applications and in particular for draining flooded areas such as cellars or for emptying tanks and reservoirs; they distinguish themselves for the ease with which they are installed and their reliability under automatic operating conditions in fixed installations.

### OPTIONALS AVAILABLE ON REQUEST

- Special mechanical seal.
- Pumps with a **10 m** long power cable
  - ➔ N.B. Standard EN 60335-2-41 states that the power cable must be 10 m long for outdoor applications
- Single-phase pumps without float switch
- Other voltages or 60 Hz frequency

### GUARANTEE

2 years subject to terms and conditions

## CHARACTERISTIC CURVES AND PERFORMANCE DATA

50 Hz n= 2900 1/min

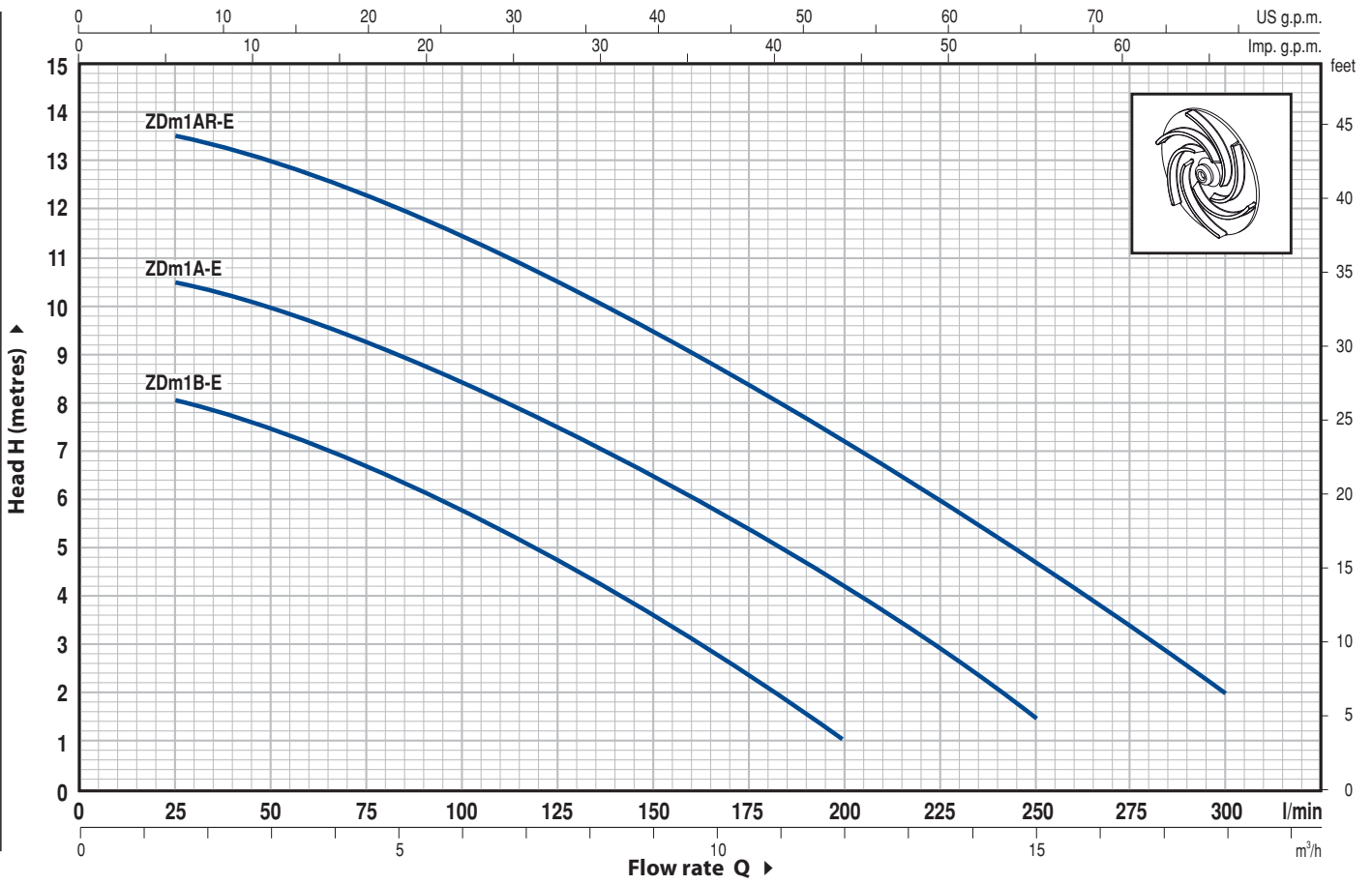

MODEL	POWER		Q	0	1.5	3.0	4.5	6.0	7.5	9.0	10.5	12.0	13.5	15.0	16.5	18.0
	kW	HP		0	25	50	75	100	125	150	175	200	225	250	275	300
Single-phase																
ZDm 1B-E	0.37	0.50	H metres	8.5	8	7.5	6.5	5.5	4.8	3.5	2.5	1				
ZDm 1A-E	0.50	0.70		11	10.5	10	9	8.5	7.5	6.5	5.5	4	2.5	1.5		
ZDm 1AR-E	0.60	0.85		14	13.5	13	12.2	11.5	10.5	9.5	8.3	7	5.7	4.5	3.2	2

Q = Flow rate H = Total manometric head

Tolerance of characteristic curves in compliance with EN ISO 9906 App. A.

POS.	COMPONENT	CONSTRUCTION CHARACTERISTICS			
1	PUMP BODY	Cast iron, with threaded port in compliance with ISO 228/1			
2	SUCTION FILTER	Stainless steel AISI 304			
3	SUCTION PLATE	Stainless steel AISI 304			
4	IMPELLER	Noryl GFN2V open type			
5	MOTOR SLEEVE	Stainless steel AISI 304			
6	MOTOR CASING	Steel			
7	MOTOR SHAFT	Stainless steel EN 10088-3 - 1.4104			
8	SHAFT WITH DOUBLE SEAL				
	<b>Seal</b>	<b>Shaft</b>			
	<i>Model</i>	<i>Diameter</i>	<i>Stationary ring</i>	<i>Rotational ring</i>	<i>Elastomer</i>
	AR-12R	Ø 12 mm	Ceramic	Graphite	NBR
9	LIP SEAL	Ø 12 x Ø 22 x H 6 mm			

10	BEARINGS	6201 ZZ / 6201 ZZ	
11	CAPACITOR		
	<b>Pump</b>	<b>Capacitance</b>	
	<i>Single-phase</i>	<i>(230 V or 240 V)</i>	<i>(110 V)</i>
	ZDm 1B-E	10 µF 450 VL	16 µF 250 VL
	ZDm 1A-E	12.5 µF 450 VL	30 µF 250 VL
	ZDm 1AR-E	16 µF 450 VL	30 µF 250 VL

12	ELECTRIC MOTOR
	– Single-phase 230 V - 50 Hz with thermal overload protector built-in to the winding.
	– Insulation: F class.
	– Protection: IP 68.

13	POWER CABLE
	5 metre long "H07 RN-F" cable with Schuko plug

14	FLOAT SWITCH
	(only for single-phase versions)

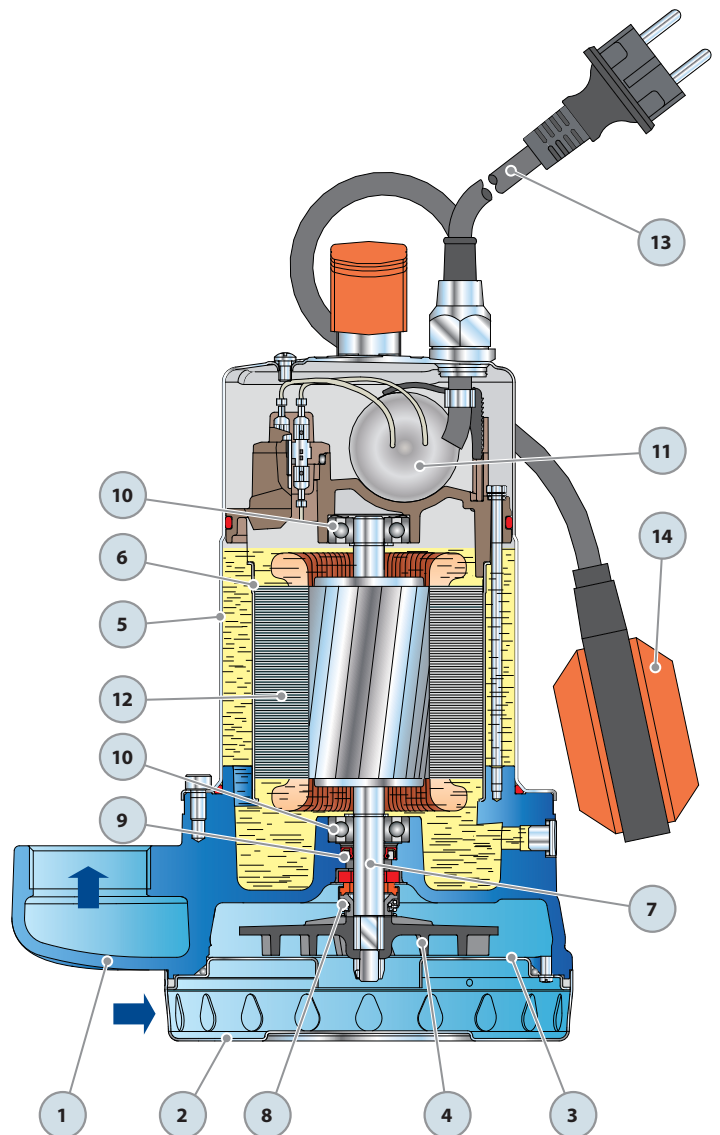

## DIMENSIONS AND WEIGHT

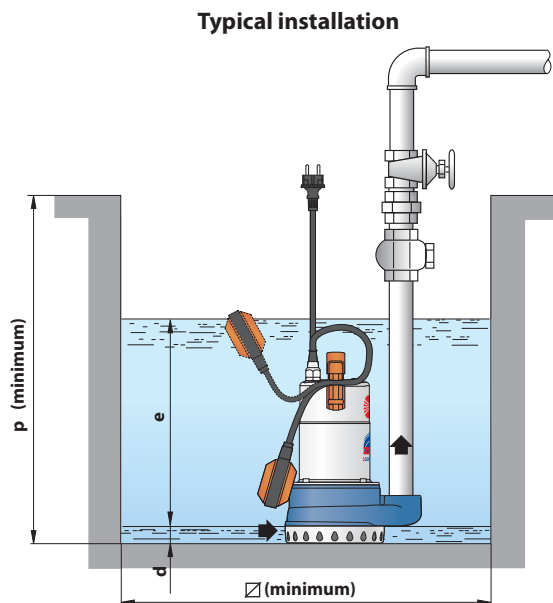
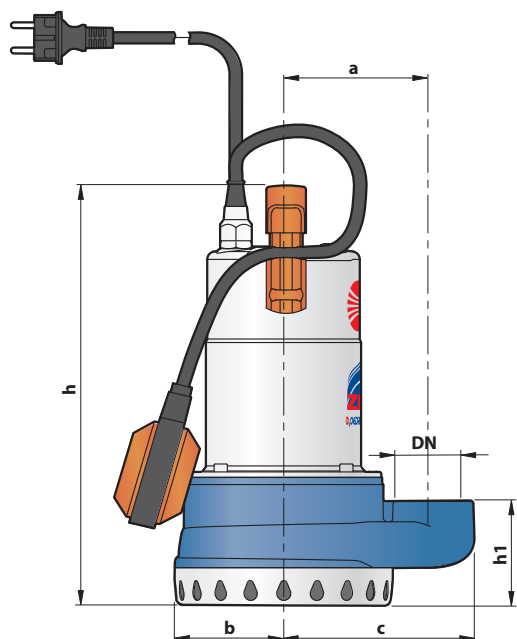

MODEL	PORT	DIMENSIONS mm									kg	
		a	b	c	h	h1	d	e	p	Ø		
Single-phase	DN											
ZDm 1B-E	1½"	110	81	142	316	77	21	variable	450	450	10.9	
ZDm 1A-E											11.5	
ZDm 1AR-E											11.8	

## ABSORPTION

MODEL	VOLTAGE (single-phase)		
	230 V	240 V	110 V
Single-phase			
ZDm 1B-E	2.5 A	2.5 A	5.2 A
ZDm 1A-E	3.3 A	3.3 A	7.0 A
ZDm 1AR-E	4.4 A	4.4 A	9.0 A

## PALLETIZATION

MODEL	GROUPAGE			CONTAINER		
	n° pumps	H (mm)	kg	n° pumps	H (mm)	kg
Single-phase						
ZDm 1B-E	60	1250	670	100	1990	1106
ZDm 1A-E	60	1250	709	100	1990	1170
ZDm 1AR-E	60	1250	726	100	1990	1199

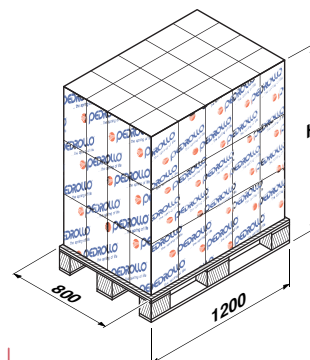

تهران، کیلومتر ۲۱ بزرگراه لشگری (جاده مخصوص کرج)

روبروی پالایشگاه نفت پارس، پلاک ۱۲