



GENERAL CATALOGUE

 **PEDROLLO**[®]
... the spring of life



PEDROLLO S.p.A.

Via Enrico Fermi 7

37047 San Bonifacio (Verona) ITALY

paid-up capital € 40.000.000,00

Tel. +39 045 6136311

Fax +39 045 7614663



PERFORMANCE RANGE

- Flow rate up to **120 l/min** (7.2 m³/h)
- Head up to **105 m**

APPLICATION LIMITS

- Manometric suction lift up to **7 m**
- Maximum liquid temperature **+40 °C**
- Max. working pressure **10 bar**
- Continuous service **S1**

CONSTRUCTION AND SAFETY STANDARDS

Complete with **2 m** long power cable

EN 60335-1
IEC 60335-1
CEI 61-150

EN 60034-1
IEC 60034-1
CEI 2-3



CERTIFICATIONS



INSTALLATION AND USE

Suitable for use with clean water and liquids that are not chemically aggressive towards the materials from which the pump is made. As a result of their reliability and quietness they are suitable for use in domestic and civil applications where there is a lack of ventilation or space as well as in wet environments, etc.

They are capable of functioning at depths of up to 20 m provided that they are equipped with a sufficiently long power cable.

OPTIONALS AVAILABLE ON REQUEST

- Other voltages or 60 Hz frequency

GUARANTEE

2 years subject to terms and conditions

CHARACTERISTIC CURVES AND PERFORMANCE DATA

50 Hz n= 2900 1/min HS= 0 m

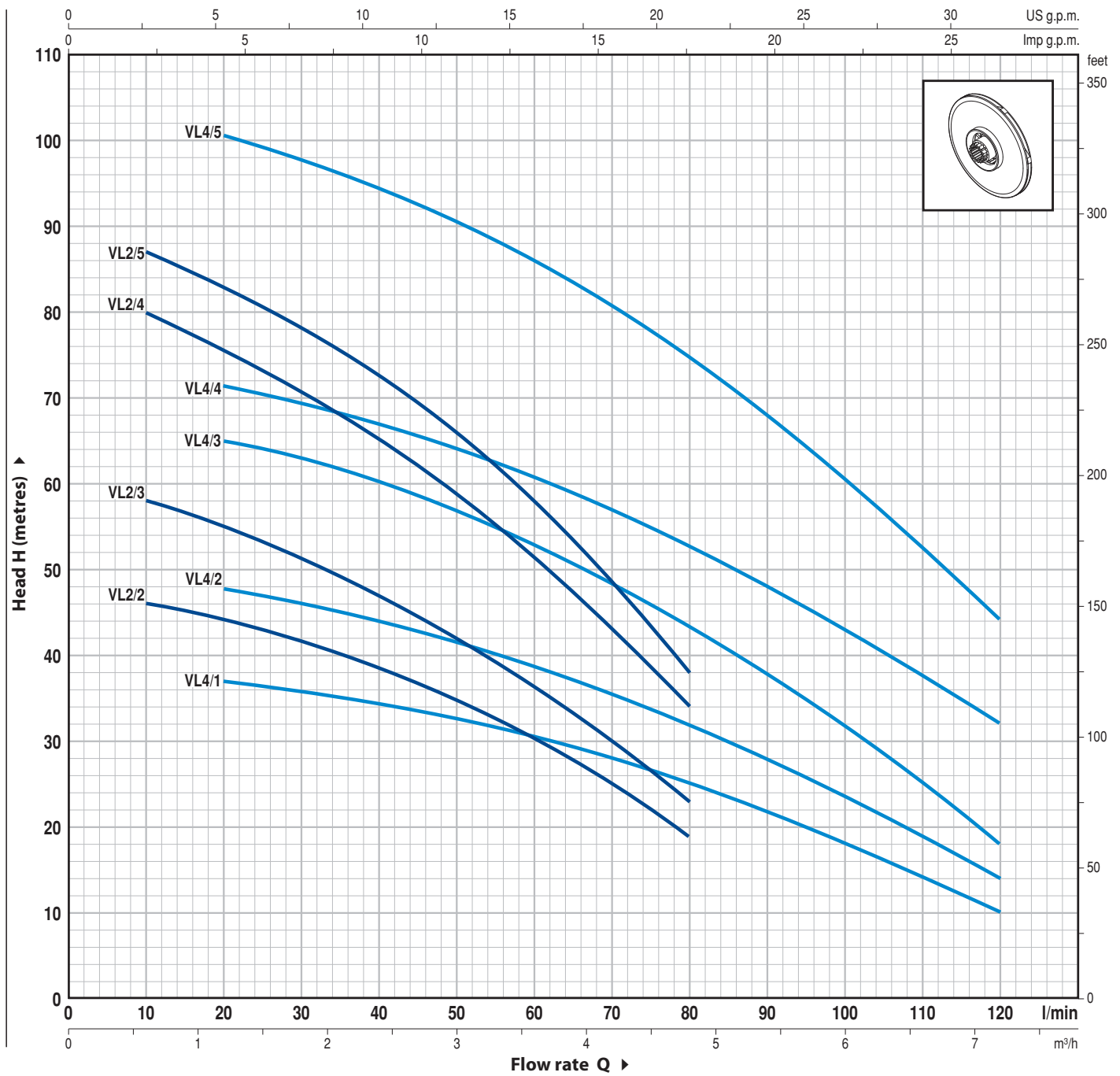

MODEL		POWER		Q	Flow rate													
Single-phase	Three-phase	kW	HP		m³/h	0	0.6	1.2	1.8	2.4	3.0	3.6	4.2	4.8	5.4	6.0	6.6	7.2
				l/min	0	10	20	30	40	50	60	70	80	90	100	110	120	
VLm 2/2	-	0.55	0.75	H metres	48	46	44	41.5	39	35	30	25	19					
VLm 2/3	VL 2/3	0.75	1		60	58	55	51	47	42	36	30	23					
VLm 2/4	VL 2/4	1.1	1.5		84	80	75	70	65	59	51	42.5	34					
VLm 2/5	VL 2/5	1.5	2		90	87	83	78	73	66	58	48	38					
VLm 4/1	-	0.55	0.75		40	-	37	36	34.5	32.5	30	28	25	21.5	18.5	14.5	10	
VLm 4/2	VL 4/2	0.75	1		50	-	48	46	44	41	38	35	32	28	24	19	14	
VLm 4/3	VL 4/3	1.1	1.5		67	-	65	62.5	60	56.5	52	48	44	38	32	25	18	
VLm 4/4	VL 4/4	1.5	2		75	-	72	69	66	64	60	57	53	48	43	38	32	
VLm 4/5	VL 4/5	2.2	3		105	-	101	98	94	90	86	80	75	67	60	52	44	

Q = Flow rate H = Total manometric head

Tolerance of characteristic curves in compliance with EN ISO 9906 App. A.

POS.	COMPONENT	CONSTRUCTION CHARACTERISTICS
------	-----------	------------------------------

1	SUCTION BODY	Stainless steel AISI 304, complete with threaded suction port in compliance with ISO 228/1
2	EXTERNAL SLEEVE	Stainless steel AISI 304, complete with threaded delivery port in compliance with ISO 228/1
3	MOTOR SLEEVE	Stainless steel AISI 304
4	IMPELLERS AND DIFFUSERS	Noryl GFN2V
5	DIAPHRAGMS	Stainless steel AISI 304, complete with anti-wear ring
6	MOTOR SHAFT	Stainless steel EN 10088-3 - 1.4104

7 TWO MECHANICAL SEALS SEPARATED BY AN OIL CHAMBER

Seal Model	Shaft Diameter	Position	Materials		
			Stationary ring	Rotational ring	Elastomer
MG1-16	Ø 16 mm	Motor side	Silicon carbide	Graphite	NBR
MG1-15 SIC	Ø 15 mm	Pump side	Silicon carbide	Silicon carbide	NBR

8 BEARINGS 6303 2RS - C3 / 6203 ZZ - C3

9 CAPACITOR

Pump	Capacitance	
Single-phase	(230 V or 240 V)	(110 V)
VLm 2/2	16 µF 500 VL	30 µF 250 VL
VLm 4/1		
VLm 2/3	20 µF 500 VL	-
VLm 4/2		
VLm 2/4	25 µF 500 VL	-
VLm 4/3		

10 ELECTRIC MOTOR

VLm: single-phase 230 V - 50 Hz with built-in overload protector.
VL: three-phase 400 V - 50 Hz.
 - Insulation: F class.
 - Protection: IP 68.

11 POWER CABLE

2 metre long "H07 RN-F" cable

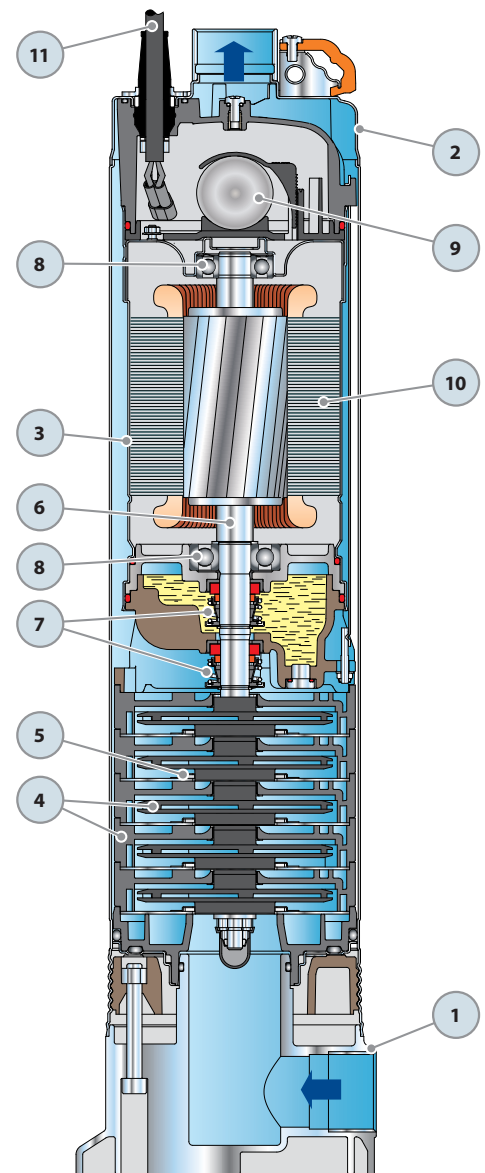

DIMENSIONS AND WEIGHT

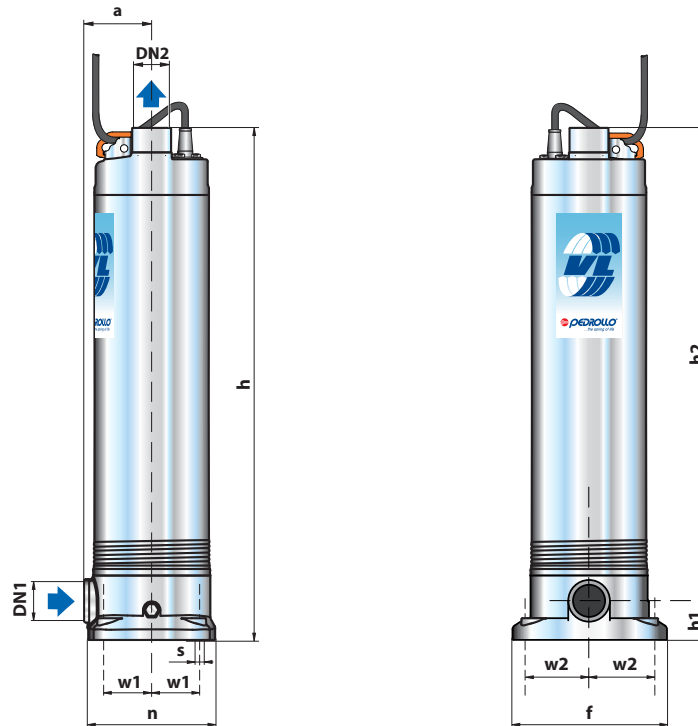

MODEL		PORTS		N° STAGES	DIMENSIONS mm									kg	
Single-phase	Three-phase	DN1	DN2		a	f	h	h1	h2	n	w1	w2	s	1~	3~
VLm 2/2	-	1 1/4"	1 1/4"	4	74	166	565	45	520	146	52.5	62.5	11	15.0	-
VLm 4/1	-			5			618		573					18.0	-
VLm 2/3	-			5			588		543					-	16.6
VLm 4/2	-			7			665		620					20.1	18.9
-	VL 2/3														
-	VL 4/2														
VLm 2/4	VL 2/4														
VLm 4/3	VL 4/3														

ABSORPTION

MODEL	VOLTAGE (single-phase)		
Single-phase	230 V	240 V	110 V
VLm 2/2	5.0 A	5.0 A	10.0 A
VLm 2/3	6.0 A	6.0 A	-
VLm 2/4	7.5 A	7.5 A	-
VLm 4/1	5.0 A	5.0 A	10.0 A
VLm 4/2	6.0 A	6.0 A	-
VLm 4/3	7.5 A	7.5 A	-

MODEL	VOLTAGE (three-phase)			
Three-phase	230 V	400 V	240 V	415 V
VL 2/3	4.5 A	2.6 A	4.5 A	2.6 A
VL 2/4	5.2 A	3.0 A	5.2 A	3.0 A
VL 4/2	4.5 A	2.6 A	4.5 A	2.6 A
VL 4/3	5.2 A	3.0 A	5.2 A	3.0 A

PALLETIZATION

MODEL		GROUPAGE				CONTAINER			
Single-phase	Three-phase	n° pumps	H (mm)	kg		n° pumps	H (mm)	kg	
				1~	3~			1~	3~
VLm 2/2	-	25	869	361	-	40	1307	615	-
VLm 4/1	-			468	-			738	-
VLm 2/3	-	25	869	-	432	40	1307	-	681
VLm 4/2	-			518	488			819	771
-	VL 2/3								
-	VL 4/2								
VLm 2/4	VL 2/4								
VLm 4/3	VL 4/3								

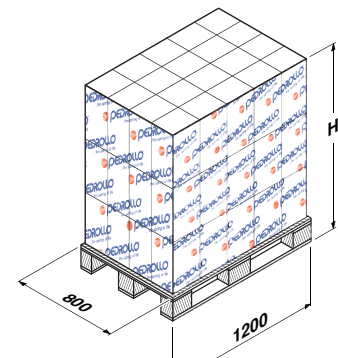

POS.	COMPONENT	CONSTRUCTION CHARACTERISTICS				
1	SUCTION BODY	Stainless steel AISI 304, complete with threaded suction port in compliance with ISO 228/1				
2	EXTERNAL SLEEVE	Stainless steel AISI 304, complete with threaded delivery port in compliance with ISO 228/1				
3	MOTOR SLEEVE	Stainless steel AISI 304				
4	IMPELLERS AND DIFFUSERS	Noryl GFN2V				
5	DIAPHRAGMS	Stainless steel AISI 304, complete with anti-wear ring				
6	MOTOR SHAFT	Stainless steel EN 10088-3 - 1.4104				
7	TWO MECHANICAL SEALS SEPARATED BY AN OIL CHAMBER					
	Seal	Shaft	Position	Materials		
	<i>Model</i>	<i>Diameter</i>		<i>Stationary ring</i>	<i>Rotational ring</i>	<i>Elastomer</i>
	MG1-19	Ø 19 mm	Motor side	Silicon carbide	Graphite	NBR
	MG1-18 SIC	Ø 18 mm	Pump side	Silicon carbide	Silicon carbide	NBR
8	BEARINGS	6304 2RS - C3 / 6203 ZZ - C3				
9	CAPACITOR					
	Pump	Capacitance				
	<i>Single-phase</i>	<i>(230 V or 240 V)</i>				
	VLm 2/5	35 µF 450 VL				
	VLm 4/4	50 µF 450 VL				
	VLm 4/5	50 µF 450 VL				
10	ELECTRIC MOTOR					
	VLm: single-phase 230 V - 50 Hz.					
	Windings up to 1.5 kW with built-in thermal overload protector.					
	➡ The VLm4/5 2.2 kW pump is equipped with an external manual reset overload protector housed in the control box.					
	VL: three-phase 400 V - 50 Hz.					
	- Insulation: F class.					
	- Protection: IP 68.					
11	POWER CABLE					
	2 metre long "H07 RN-F" cable with removable connector					
12	CONTROL BOX (for single-phase versions only)					
	Complete with capacitor and power cable with Schuko plug					

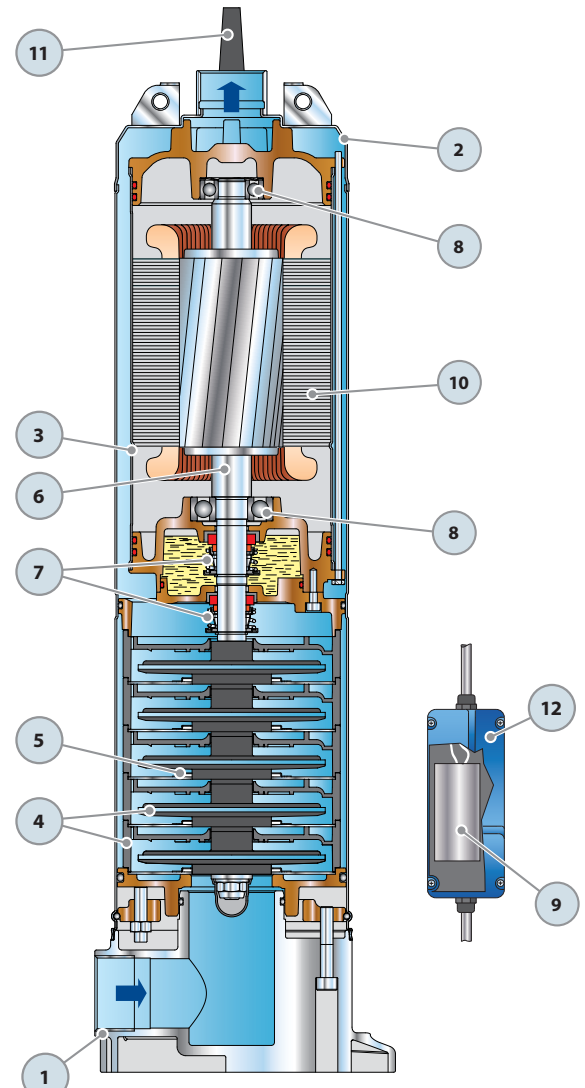

DIMENSIONS AND WEIGHT

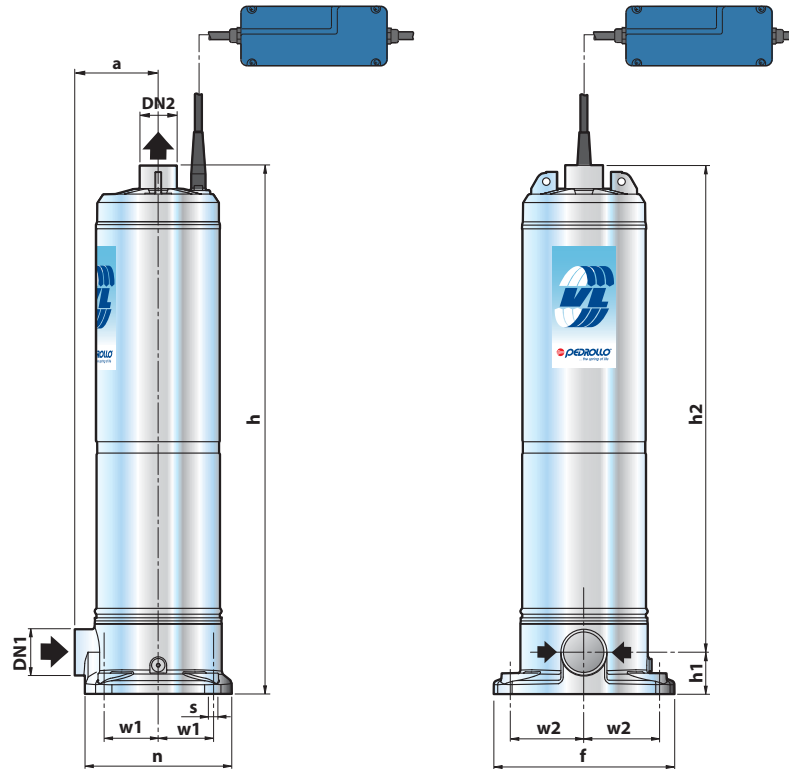

MODEL		PORTS		N° STAGES	DIMENSIONS mm									kg	
Single-phase	Three-phase	DN1	DN2		a	f	h	h1	h2	n	w1	w2	s	1~	3~
VLm 2/5	VL 2/5	1½"	1¼"	6	100	223	663	50	613	183	62	88.5	11	31.7	28.8
VLm 4/4	VL 4/4			5	633		583		31.0					29.4	
VLm 4/5	VL 4/5			7	693		643		35.5					33.0	

ABSORPTION

MODEL	VOLTAGE (single-phase)	
Single-phase	230 V	240 V
VLm 2/5	9.0 A	9.0 A
VLm 4/4	9.5 A	9.5 A
VLm 4/5	14.0 A	14.0 A

MODEL	VOLTAGE (three-phase)			
Three-phase	230 V	400 V	240 V	415 V
VL 2/5	6.2 A	3.6 A	6.2 A	3.6 A
VL 4/4	6.2 A	3.6 A	6.2 A	3.6 A
VL 4/5	8.5 A	4.9 A	8.5 A	4.9 A

PALLETIZATION

MODEL		GROUPAGE				CONTAINER			
Single-phase	Three-phase	n° pumps	H (mm)	kg		n° pumps	H (mm)	kg	
				1~	3~			1~	3~
VLm 2/5	VL 2/5	25	1340	809	737	40	2060	1285	1169
VLm 4/4	VL 4/4	25	1340	792	752	40	2060	1258	1193
VLm 4/5	VL 4/5	25	1340	905	841	40	2060	1437	1336

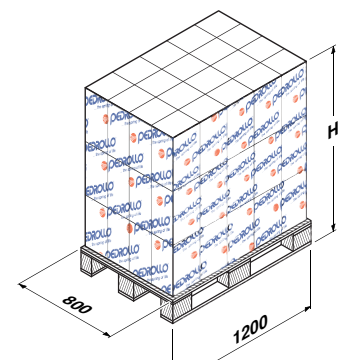



PERFORMANCE RANGE

- Flow rate up to **120 l/min** (7.2 m³/h)
- Head up to **105 m**

APPLICATION LIMITS

- Manometric suction lift up to **7 m**
- Maximum liquid temperature **+40 °C**
- Max. working pressure **10 bar**
- Continuous service **S1**

CONSTRUCTION AND SAFETY STANDARDS

Complete with **2 m** long power cable

EN 60335-1
IEC 60335-1
CEI 61-150

EN 60034-1
IEC 60034-1
CEI 2-3



CERTIFICATIONS



INSTALLATION AND USE

Suitable for use with clean water and liquids that are not chemically aggressive towards the materials from which the pump is made. As a result of their reliability, quietness, high efficiency and leak proof design in the event of seal failure, they are suitable for use in domestic and civil applications where there is a lack of ventilation or space as well as in closed spaces, wet areas and on delicate surfaces (e.g. wooden floorboards, carpets, etc). They are capable of functioning at depths of up to 20 m provided that they are equipped with a sufficiently long power cable.

OPTIONALS AVAILABLE ON REQUEST

- Other voltages or 60 Hz frequency

GUARANTEE

2 years subject to terms and conditions

CHARACTERISTIC CURVES AND PERFORMANCE DATA

50 Hz n= 2900 1/min HS= 0 m

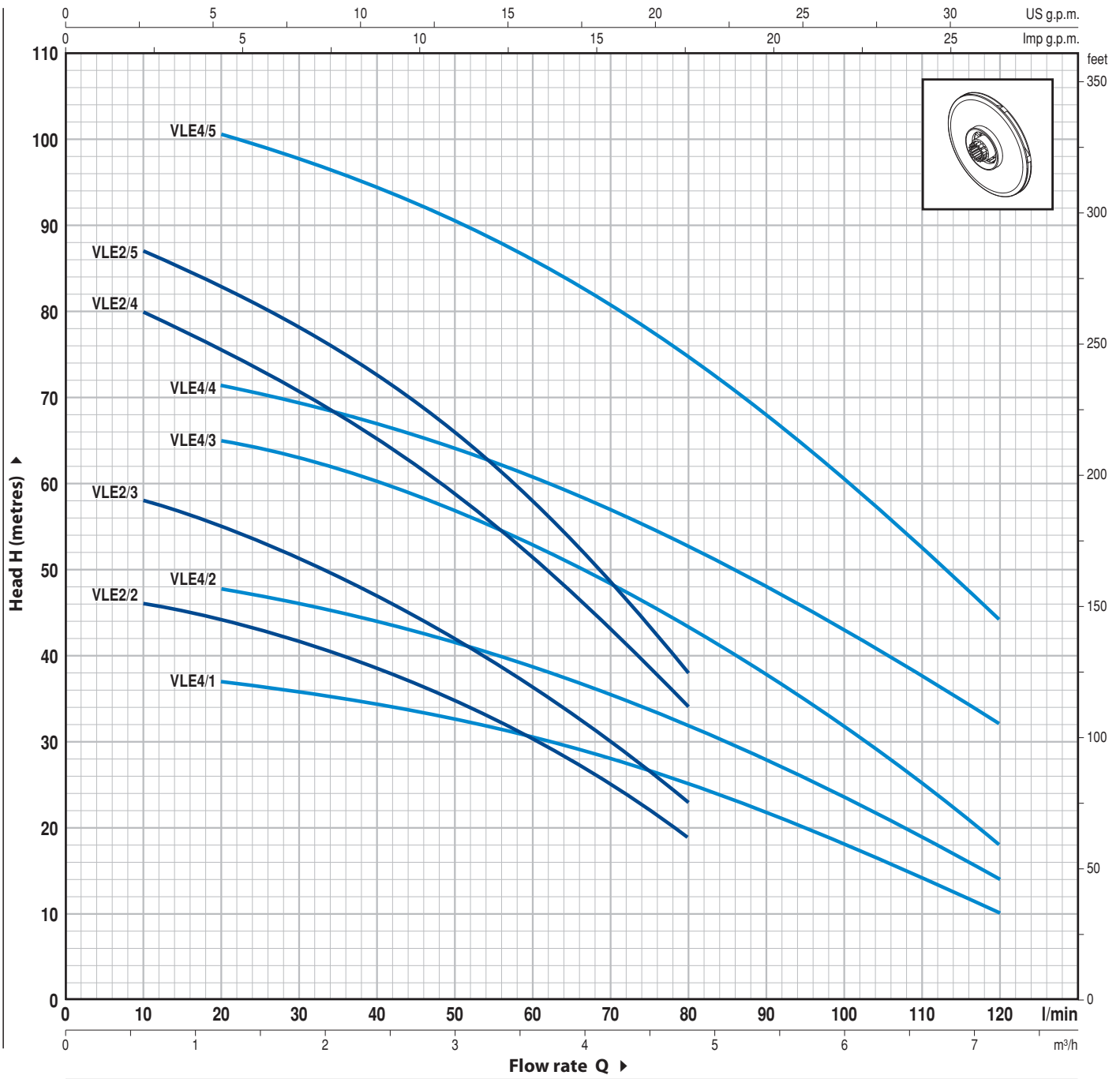

MODEL		POWER		Q	Flow rate (m³/h)												
Single-phase	Three-phase	kW	HP		0	0.6	1.2	1.8	2.4	3.0	3.6	4.2	4.8	5.4	6.0	6.6	7.2
				l/min	0	10	20	30	40	50	60	70	80	90	100	110	120
VLEm 2/2	-	0.55	0.75	H metres	48	46	44	41.5	39	35	30	25	19				
VLEm 2/3	VLE 2/3	0.75	1		60	58	55	51	47	42	36	30	23				
VLEm 2/4	VLE 2/4	1.1	1.5		84	80	75	70	65	59	51	42.5	34				
VLEm 2/5	VLE 2/5	1.5	2		90	87	83	78	73	66	58	48	38				
VLEm 4/1	-	0.55	0.75		40	-	37	36	34.5	32.5	30	28	25	21.5	18.5	14.5	10
VLEm 4/2	VLE 4/2	0.75	1		50	-	48	46	44	41	38	35	32	28	24	19	14
VLEm 4/3	VLE 4/3	1.1	1.5		67	-	65	62.5	60	56.5	52	48	44	38	32	25	18
VLEm 4/4	VLE 4/4	1.5	2		75	-	72	69	66	64	60	57	53	48	43	38	32
VLEm 4/5	VLE 4/5	2.2	3		105	-	101	98	94	90	86	80	75	67	60	52	44

Q = Flow rate H = Total manometric head

Tolerance of characteristic curves in compliance with EN ISO 9906 App. A.

POS.	COMPONENT	CONSTRUCTION CHARACTERISTICS				
1	SUCTION BODY	Stainless steel AISI 304, complete with threaded suction port in compliance with ISO 228/1				
2	EXTERNAL SLEEVE	Stainless steel AISI 304, complete with threaded delivery port in compliance with ISO 228/1				
3	MOTOR SLEEVE	Stainless steel AISI 304				
4	IMPELLERS AND DIFFUSERS	Noryl GFN2V				
5	DIAPHRAGMS	Stainless steel AISI 304, complete with anti-wear ring				
6	MOTOR SHAFT	Stainless steel EN 10088-3 - 1.4104				
7	TWO MECHANICAL SEALS SEPARATED BY AN OIL CHAMBER					
	Seal	Shaft	Position	Materials		
	<i>Model</i>	<i>Diameter</i>		<i>Stationary ring</i>	<i>Rotational ring</i>	<i>Elastomer</i>
	MG1-16	Ø 16 mm	Motor side	Silicon carbide	Graphite	NBR
	MG1-15 SIC	Ø 15 mm	Pump side	Silicon carbide	Silicon carbide	NBR
8	BEARINGS	6303 2RS - C3 / 6203 ZZ - C3				
9	CAPACITOR					
	Pump	Capacitance				
	<i>Single-phase</i>	<i>(230 V or 240 V)</i>		<i>(110 V)</i>		
	VLEm 2/2	16 µF 500 VL		30 µF 250 VL		
	VLEm 4/1					
	VLEm 2/3	20 µF 500 VL		-		
	VLEm 4/2					
	VLEm 2/4	25 µF 500 VL		-		
	VLEm 4/3					
10	ELECTRIC MOTOR					
	VLEm: single-phase 230 V - 50 Hz with built-in overload protector.					
	VLE: three-phase 400 V - 50 Hz.					
	- Insulation: F class.					
	- Protection: IP 68.					
11	POWER CABLE					
	2 metre long "H07 RN-F" cable					

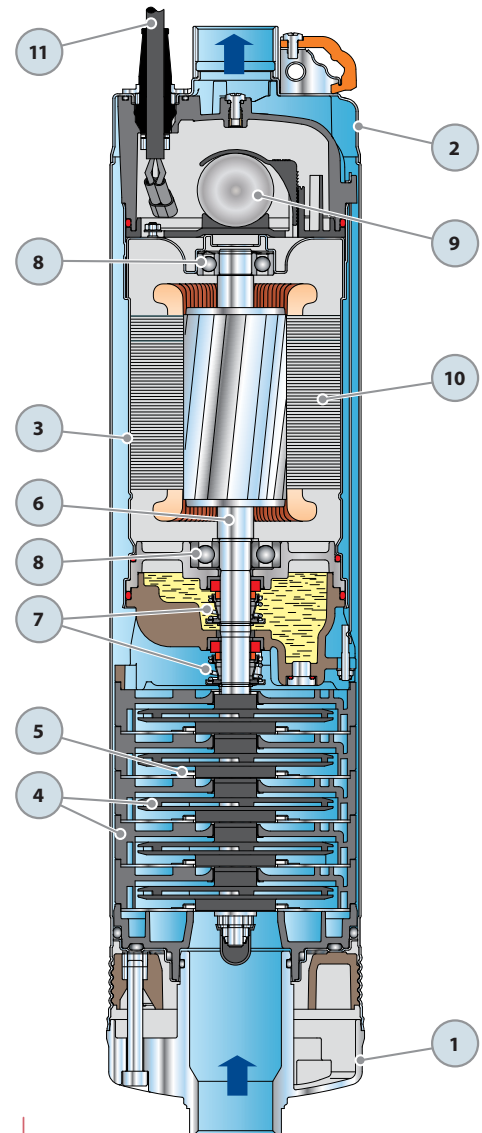

تهران، کیلومتر ۲۱ بزرگراه لشگری (جاده مخصوص کرج)

روبروی پالایشگاه نفت پارس، پلاک ۱۲

DIMENSIONS AND WEIGHT

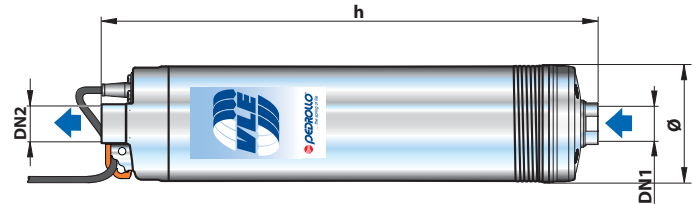
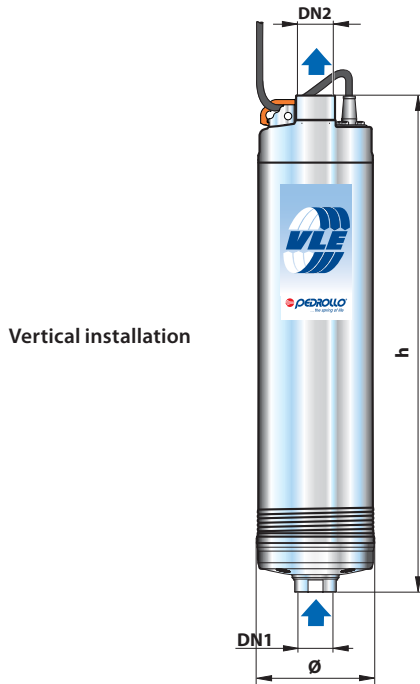

MODEL		PORTS		N° STAGES	DIMENSIONS mm		kg	
Single-phase	Three-phase	DN1	DN2		ø	h	1~	3~
VLEm 2/2 VLEm 4/1	-	1 1/4"	1 1/4"	4	135	546	14.0	-
VLEm 2/3 VLEm 4/2	-			5		600	16.0	-
-	VLE 2/3 VLE 4/2			7		570	-	14.6
VLEm 2/4 VLEm 4/3	VLE 2/4 VLE 4/3			7		648	18.1	16.8

ABSORPTION

MODEL	VOLTAGE (single-phase)		
	230 V	240 V	110 V
Single-phase	230 V	240 V	110 V
VLEm 2/2	5.0 A	5.0 A	10.0 A
VLEm 2/3	6.0 A	6.0 A	-
VLEm 2/4	7.5 A	7.5 A	-
VLEm 4/1	5.0 A	5.0 A	10.0 A
VLEm 4/2	6.0 A	6.0 A	-
VLEm 4/3	7.5 A	7.5 A	-

MODEL	VOLTAGE (three-phase)			
	230 V	400 V	240 V	415 V
Three-phase	230 V	400 V	240 V	415 V
VLE 2/3	4.5 A	2.6 A	4.5 A	2.6 A
VLE 2/4	5.2 A	3.0 A	5.2 A	3.0 A
VLE 4/2	4.5 A	2.6 A	4.5 A	2.6 A
VLE 4/3	5.2 A	3.0 A	5.2 A	3.0 A

PALLETIZATION

MODEL		GROUPAGE				CONTAINER			
Single-phase	Three-phase	n° pumps	H (mm)	kg		n° pumps	H (mm)	kg	
				1~	3~			1~	3~
VLEm 2/2 VLEm 4/1	-	36	1190	522	-	60	1890	859	-
VLEm 2/3 VLEm 4/2	-	25	869	417	-	40	1307	658	-
-	VLE 2/3 VLE 4/2	25	869	-	382	40	1307	-	601
VLEm 2/4 VLEm 4/3	VLE 2/4 VLE 4/3	25	869	470	437	40	1307	741	689

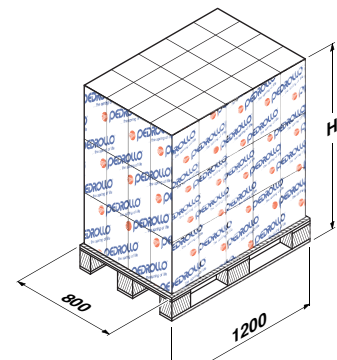

POS.	COMPONENT	CONSTRUCTION CHARACTERISTICS				
1	PUMP BODY	Stainless steel AISI 304, complete with threaded suction port in compliance with ISO 228/1				
2	EXTERNAL SLEEVE	Stainless steel AISI 304, complete with threaded delivery port in compliance with ISO 228/1				
3	MOTOR SLEEVE	Stainless steel AISI 304				
4	IMPELLERS AND DIFFUSERS	Noryl GFN2V				
5	DIAPHRAGMS	Stainless steel AISI 304, complete with anti-wear ring				
6	MOTOR SHAFT	Stainless steel EN 10088-3 - 1.4104				
7	TWO MECHANICAL SEALS SEPARATED BY AN OIL CHAMBER					
	<i>Seal</i>	<i>Shaft</i>	<i>Position</i>	<i>Materials</i>		
	<i>Model</i>	<i>Diameter</i>		<i>Stationary ring</i>	<i>Rotational ring</i>	<i>Elastomer</i>
	MG1-19	Ø 19 mm	Motor side	Silicon carbide	Graphite	NBR
	MG1-18 SIC	Ø 18 mm	Pump side	Silicon carbide	Silicon carbide	NBR
8	BEARINGS	6304 2RS - C3 / 6203 ZZ - C3				
9	CAPACITOR					
	<i>Pump</i>	<i>Capacitance</i>				
	<i>Single-phase</i>	<i>(230 V or 240 V)</i>				
	VLEm 2/5	35 µF 450 VL				
	VLEm 4/4	50 µF 450 VL				
	VLEm 4/5	50 µF 450 VL				
10	ELECTRIC MOTOR					
	VLEm: single-phase 230 V - 50 Hz.		Windings up to 1.5 kW with built-in thermal overload protector.			
	⇒ The VLEm4/5 2.2 kW pump is equipped		with an external manual reset overload protector housed in the control box.			
	VLE: three-phase 400 V - 50 Hz.		- Insulation: F class.			
			- Protection: IP 68.			
11	POWER CABLE					
	2 metre long "H07 RN-F" cable with removable connector					
12	CONTROL BOX (for single-phase versions)					
	Complete with capacitor and power cable with Schuko plug					

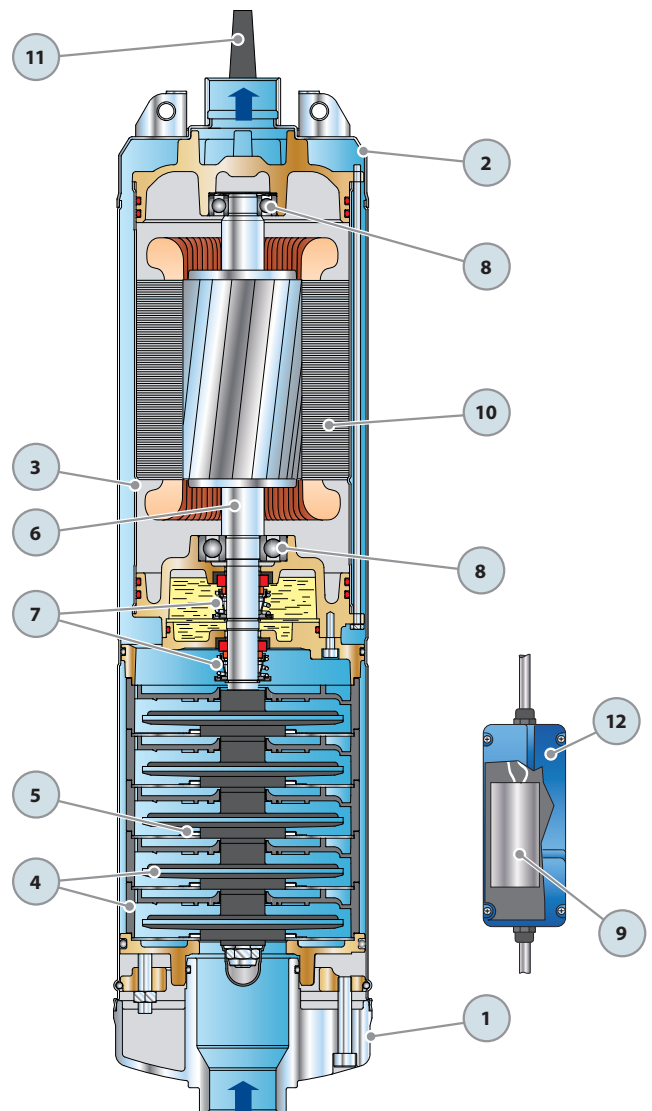

تهران، کیلومتر ۲۱ بزرگراه لشگری (جاده مخصوص کرج)
روبروی پالایشگاه نفت پارس، پلاک ۱۲

Tel: ۰۲۱-۴۸۰۰۰۰۴۹

Fax: ۰۲۱-۴۴۹۹۴۶۴۲

www.famcocorp.com

E-mail: info@famcocorp.com

@famco_group

DIMENSIONS AND WEIGHT

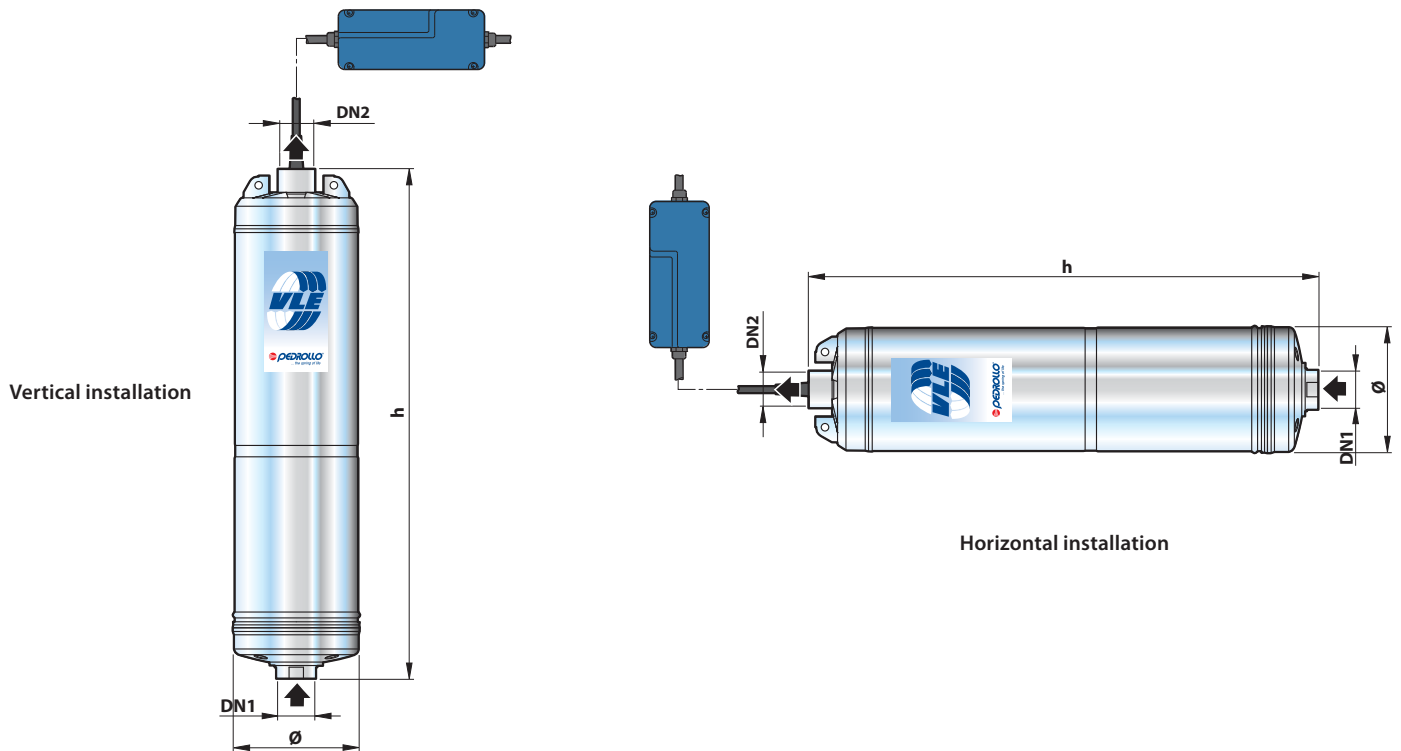

MODEL		PORTS		N° STAGES	DIMENSIONS mm		kg	
Single-phase	Three-phase	DN1	DN2		ø	h	1~	3~
VLEm 2/5	VLE 2/5	1 1/4"	1 1/4"	6	153	640	28.7	25.8
VLEm 4/4	VLE 4/4			5		610	28.0	26.4
VLEm 4/5	VLE 4/5			7		670	32.5	30.0

ABSORPTION

MODEL	VOLTAGE (single-phase)	
Single-phase	230 V	240 V
VLEm 2/5	9.0 A	9.0 A
VLEm 4/4	9.5 A	9.5 A
VLEm 4/5	14.0 A	14.0 A

MODEL	VOLTAGE (three-phase)			
Three-phase	230 V	400 V	240 V	415 V
VLE 2/5	6.2 A	3.6 A	6.2 A	3.6 A
VLE 4/4	6.2 A	3.6 A	6.2 A	3.6 A
VLE 4/5	8.5 A	4.9 A	8.5 A	4.9 A

PALLETIZATION

MODEL		GROUPAGE				CONTAINER			
Single-phase	Three-phase	n° pumps	H (mm)	kg		n° pumps	H (mm)	kg	
				1~	3~			1~	3~
VLEm 2/5	VLE 2/5	25	1340	734	662	40	2060	1165	1049
VLEm 4/4	VLE 4/4	25	1340	717	677	40	2060	1138	1073
VLEm 4/5	VLE 4/5	25	1340	830	766	40	2060	1317	1216

