

Two impeller compact centrifugal pumps for constructing pressurisation systems for civil and industrial plant: guarantee good ratio between pressure and flow rate.

Construction features

Pump body	cast iron
Motor bracket	cast iron
Impeller	Noryl® or brass
Mechanical seal	ceramic-graphite-NBR
Motor shaft	stainless steel AISI 303
Liquid temperature	0 - 50 °C
Operating pressure	max 8 bar

Motor

	3- 230/400V - 50Hz
2 Poles induction motor	1- 230V - 50Hz (with thermal protection)
Insulation class	F
Protection degree	IPX4

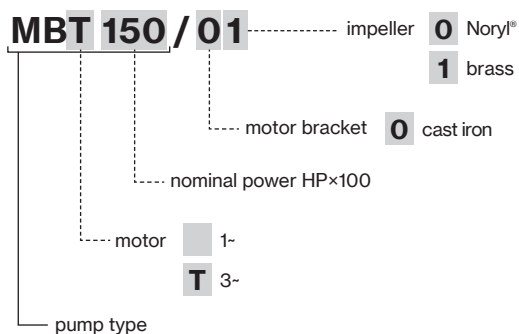

TYPE	LOTS			
	TRUCK		CONTAINER	
	PALLET (cm)	N° pumps	PALLET (cm)	N° pumps
MB	85×110×130	40	85×110×190	60



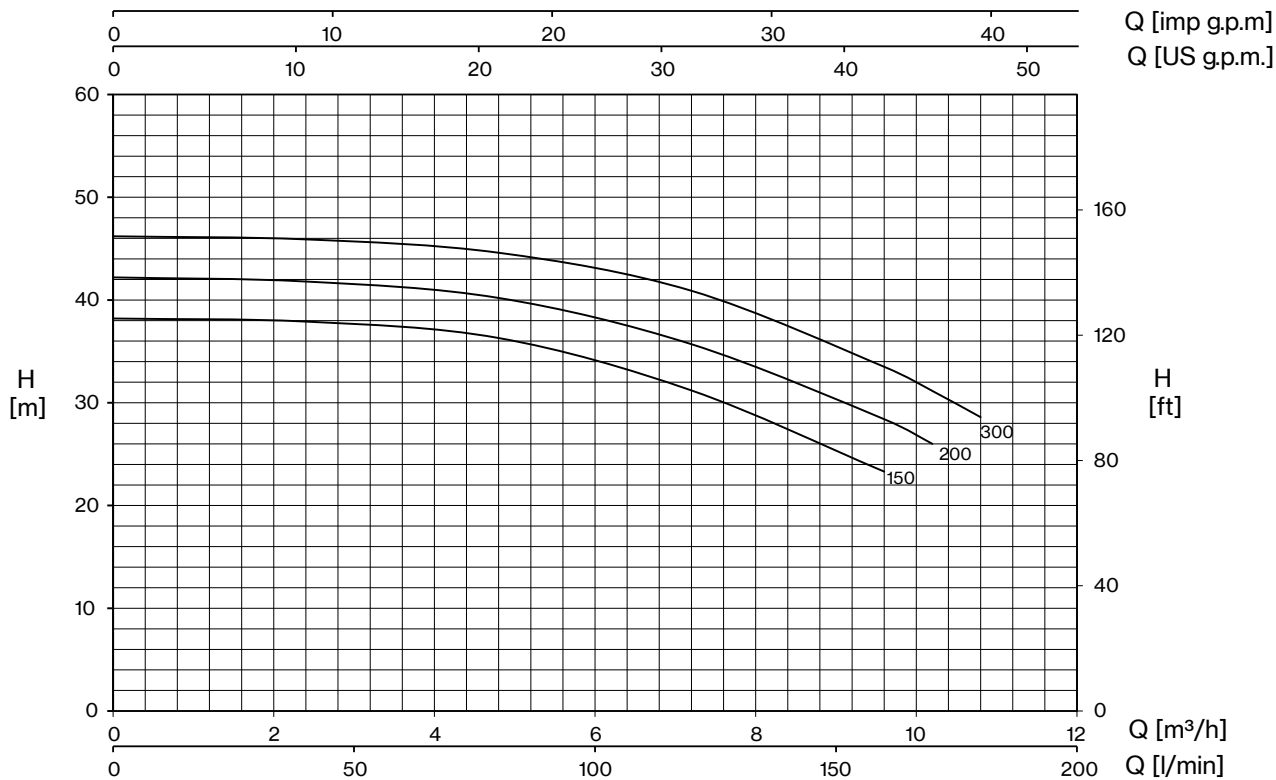

TYPE		P2		P1 (kW)		AMPERE		Q (m³/h - l/min)						
1~	3~	HP	kW	1~	3~	1~	3~	0	2,4	4,8	7,2	9,6	10,2	10,8
						1~ 230V 50 Hz	3~ 400V 50 Hz	0	40	80	120	160	170	180
								H (m)						
MB 150	MBT 150	1,5	1,1	1,6	1,5	7,2	3,1	38,2	37,9	36,3	31,2	23,3		
MB 200	MBT 200	2	1,5	1,85	1,75	8,4	3,4	42,2	41,8	40,2	35,7	28,4	26,0	
MB 300	MBT 300	3	2,2	2,15	2,05	9,7	4,3	46,2	45,9	44,6	40,9	33,5	31,2	28,6

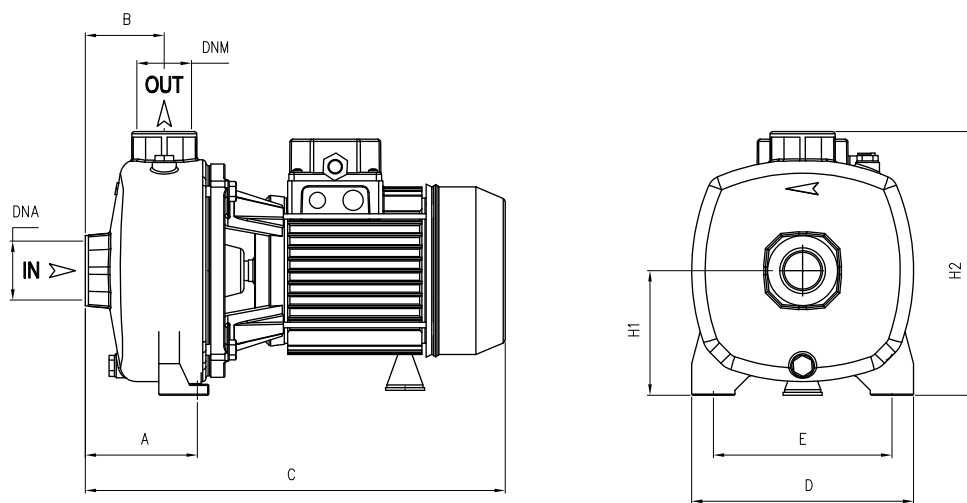

TYPE	DIMENSIONS (mm)													
	A	B	C	D	E	H1	H2	DNA	DNM	I	L	M	kg	T
MB 150	108	73	385	205	165	115	242			405	225	295	22	T 21
MB 200	108	73	385	205	165	115	242	1" 1/2 G	1" 1/4 G	405	225	295	22,5	T 21,5
MB 300	108	73	385	205	165	115	242			405	225	295	23,5	T 22,5

