

ELETTROPOMPE SOMMERSE INOX  
PER ACQUE CARICHE

STAINLESS STEEL SUBMERSIBLE PUMPS  
FOR DIRTY WATER

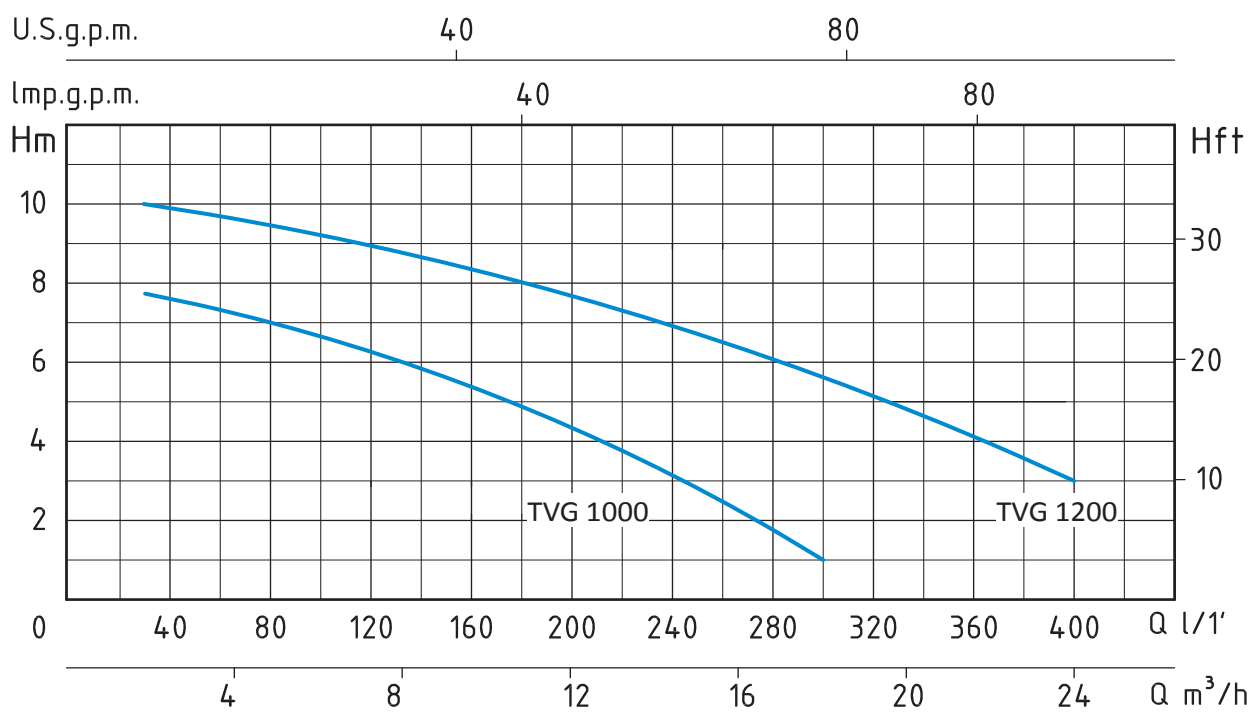

**TVG - 50 HZ - 1 PHASE**

TIPO TYPE	POTENZA ASSORBITA INPUT POWER	AMPERE	Condensatore Capacitor	Q = PORTATA - CAPACITY											
				m³/h	1,8	3,6	5,4	7,2	9	12	15	18	21	24	
Monofase Single-phase	P1	Monofase Single-phase	µf	lt/1'	30	60	90	120	150	200	250	300	350	400	
	Watt			Prevalenza manometrica totale in m.C.A. - Total head in meters w.c.											
TVG 1000	1100 W	5	16	H	7,8	7,5	7	6,2	5,8	4,2	3	1			
TVG 1200	1400 W	6,5	20	(m)	10	9,5	9,2	8,5	8,2	7,8	6,5	5,8	4,2	3	

### APPLICAZIONI

Elettropompe sommersa inox per drenaggio con girante in acciaio inox adatte per svuotamento di fosse di decantazione e per pompaggio di acque luride ad uso domestico e civile. Possono essere usate anche per acqua leggermente acida.

### LIMITI D'IMPIEGO

- Temperatura liquido fino a 35°C (per un uso domestico secondo EN 60335-2-41)
- Temperatura max. liquido: 35°C (per altri impieghi)
- Massima profondità d'immersione 5 mt.
- Passaggio solidi Ø 35 mm
- Livello min. d'aspirazione 65 mm
- Servizio continuo

### MOTORE

- Monofase 230V-50Hz
- Doppia camera con motore in bagno d'olio per raffreddamento e lubrificazione cuscinetti
- Tenuta meccanica in bagno d'olio
- Condensatore permanente inserito
- Isolamento Classe F
- Protezione IP 68

### MATERIALI

- Maniglia Acciaio Inox AISI 304
- Cassa motore Acciaio Inox AISI 304
- Corpo pompa Ghisa
- Girante Acciaio Inox AISI 304
- Griglia aspirazione Acciaio Inox AISI 304
- Albero motore Acciaio Inox AISI 304
- Tenuta meccanica Ceramica/Grafite/NBR

### APPLICATION

Drainage submersible stainless steel water pumps with stainless steel impeller. Able to drain decanting cesspools and to pump waste water for domestic and civil purposes. They can also be used for slightly acidic water.

### OPERATING CONDITIONS

- Liquid temperature up to 35°C (for home use according to EN 60335-2-41)
- Temperature max. liquid: 35°C (for other uses)
- Maximum immersion depth 5 mt.
- Grain size inlet Ø 35 mm
- Min. suction level 65 mm
- Continuous duty

### MOTOR

- Single-phase 230V-50Hz
- Dual chamber with oil bath motor for cooling and bearing lubrication
- Mechanical seal in oil bath
- Permanent split capacitor
- Insulation Class F
- Protection IP 68

### MATERIALS

- Handle Stainless Steel AISI 304
- Motor casing Stainless Steel AISI 304
- Pump body Cast Iron
- Impeller Stainless Steel AISI 304
- Suction grid Stainless Steel AISI 304
- Shaft with rotor Stainless Steel AISI 304
- Mechanical seal Ceramic/Graphite/NBR

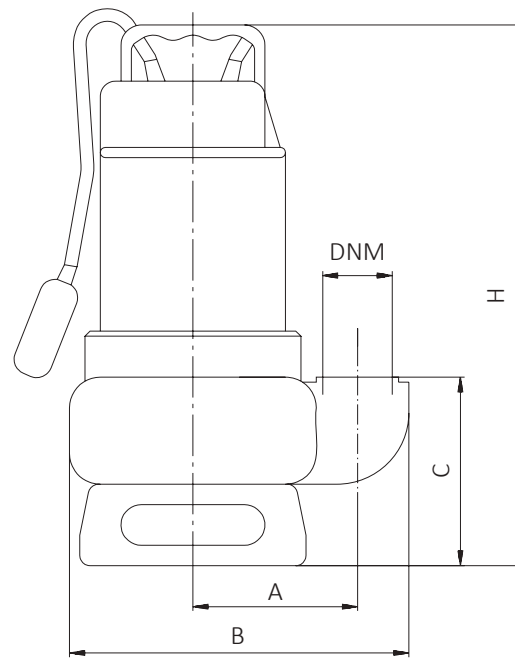

TIPO TYPE	DIMENSIONI mm- DIMENSIONS mm						DIMENSIONI DIMENSIONS mm			PESO WEIGHT Kg
	A	B	C	H	DNM	CAVO CABLE	P	L	H	
Monofase Single-phase										
TVG 1000	112	232	131	368	1" 1/2	10 mt H07RNF	195	232	415	13,1
TVG 1200	112	232	131	368	2"	10 mt H07RNF	195	232	415	14,4