

# TRUECOAT<sup>®</sup> 360

TRUEAIRLESS™

3A9014C

EN

## Project Series Paint Sprayers



### Important Safety Instructions

Read all warnings and instructions in this manual, and on the unit, including the power cord, before using the equipment. Be familiar with the controls and the proper usage of the equipment. Save these instructions.



### Important Medical Information

Read the medical alert card provided with the gun. It contains injection injury treatment information for a doctor. Keep it with you when operating the equipment.

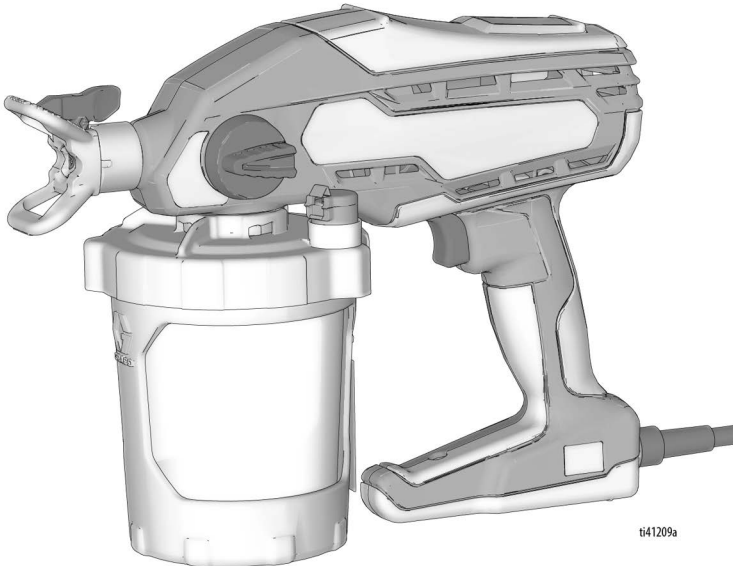

ti41209a

**For portable spray applications of water-based and oil-based non-flammable architectural paints and coatings only. For Household Use Only.**

www.famcocorp.com

E-mail: info@famcocorp.com

@famco\_group

Tel: +91-48000049

Fax: +91-44994642

تهران، کیلومتر ۲۱ بزرگراه لشگری (جاده مخصوص کرج)

روبروی پالایشگاه نفت پارس، پلاک ۱۲

# Before You Spray

## Review Warnings for Important Safety Information

Important! Read carefully and practice good safety habits.

### Models

	Model	Name	Voltage	Description	Maximum Working Pressure
 Intertek 110474 Certified to CAN/CSA C22.2 No. 68 Conforms to UL 1450	26D280 CAN280	TrueCoat 360	120V	Single Speed	2000 psi (13.8 MPa, 138 bar)
	26D281 CAN281	TrueCoat 360 DS	120V	Dual Speed	
	26D282 CAN282	TrueCoat 360 DSP	120V	Dual Speed Premium	
	26D283 CAN283	TrueCoat 360 VSP	120V	Variable Speed Premium	

### Online Resources

Visit Our Website:	<a href="http://graco.com/homeowner">graco.com/homeowner</a>
Operational Videos:	<a href="http://graco.com/homeeducationcenter">graco.com/homeeducationcenter</a>
Manuals:	<a href="http://graco.com/homeownersupport">graco.com/homeownersupport</a>
Parts Online:	<a href="http://graco.com/homeownerparts">graco.com/homeownerparts</a>

## Important User Information

### Thank You for Your Purchase!

Congratulations! You have purchased a high-quality paint sprayer made by Graco Inc. This sprayer is designed to provide superior spray performance with water-based and oil-based (mineral spirit-type) architectural paints and coatings. This user information is intended to help you understand the types of materials that can be used with your sprayer.

Please read the information on the material container label to determine if it can be used with your sprayer. Ask for a Safety Data Sheet (SDS) from your supplier. The container label and SDS will explain the contents of the material and the specific precautions related to it.

Paints, coatings and clean-up materials generally fit into one of the following **3 basic categories**:



**WATER-BASED:** The container label should indicate that the material can be cleaned up with soap and water. Your sprayer is compatible with this type of material. Your sprayer is **NOT** compatible with harsh cleaners such as chlorine bleach.



**OIL-BASED:** The container label should indicate that the material is COMBUSTIBLE and can be cleaned up with mineral spirits or paint thinner. The SDS must indicate that the flash point of the material is above 100° F. Your sprayer is compatible with this type of material. Use oil-based material outdoors or in a well-ventilated indoor area with a flow of fresh air. See the safety warnings in this manual.



**FLAMMABLE:** This type of material contains flammable solvents such as xylene, toluene, naphtha, MEK, lacquer thinner, acetone, denatured alcohol, and turpentine. The container label should indicate that this material is FLAMMABLE. This type of material is **NOT** compatible with your sprayer and **CANNOT** be used.



### WARNING

#### FIRE AND EXPLOSION HAZARD

- Use only non-flammable or water-based materials, or non-flammable paint thinners. Do not use materials having flash points lower than 100° F (38° C). This includes, but is not limited to, acetone, xylene, toluene, or naphtha. For more information about your material, request Safety Data Sheets (SDSs) from the supplier.

### NOTICE

Your sprayer is **NOT** compatible with harsh cleaners such as chlorine bleach. Using these cleaners will cause damage to the sprayer.

# Contents

<b>Before You Spray</b> . . . . .	<b>2</b>
<b>Important User Information</b> . . . . .	<b>3</b>
<b>Contents</b> . . . . .	<b>4</b>
<b>Warnings</b> . . . . .	<b>5</b>
<b>Know Your Sprayer</b> . . . . .	<b>9</b>
<b>Know Your Controls</b> . . . . .	<b>10</b>
<b>Setup</b> . . . . .	<b>11</b>
Pressure Relief Procedure . . . . .	11
Cup Fill . . . . .	11
<b>Startup</b> . . . . .	<b>14</b>
<b>Spraying</b> . . . . .	<b>16</b>
Spray Tip Orientation . . . . .	16
Spray Pattern Quality . . . . .	17
Spray Angle . . . . .	17
Aiming Sprayer . . . . .	17
Triggering Timing . . . . .	17
Reversible Spray Tips . . . . .	18
Spray Tip Removal . . . . .	18
Spray Tip Installation . . . . .	18
Clear Tip Clogs . . . . .	19
Cup Refills . . . . .	20
Pause in Spraying . . . . .	20
<b>Cleanup</b> . . . . .	<b>21</b>
Fluid Compatibility . . . . .	21
Static Grounding Instructions (Oil-Based Materials) . . . . .	21
Cleaning Sprayer . . . . .	22
<b>Storage</b> . . . . .	<b>24</b>
<b>Recycling and Disposal</b> . . . . .	<b>25</b>
End of Product Life . . . . .	25
<b>Troubleshooting</b> . . . . .	<b>26</b>
<b>Replacement Parts</b> . . . . .	<b>30</b>
Single Speed, Dual Speed, Dual Speed Premium . . . . .	30
Parts List- Single Speed, Dual Speed, Dual Speed Premium . . . . .	31
<b>Replacement Parts</b> . . . . .	<b>32</b>
Variable Speed Premium . . . . .	32
Parts List- Variable Speed Premium . . . . .	33
<b>Technical Specifications</b> . . . . .	<b>34</b>
<b>Graco Standard Warranty</b> . . . . .	<b>35</b>

## Warnings

The following warnings are for the setup, use, grounding, maintenance, and repair of this equipment. The exclamation point symbol alerts you to a general warning and the hazard symbols refer to procedure-specific risks. When these symbols appear in the body of this manual or on warning labels, refer back to these Warnings. Product-specific hazard symbols and warnings not covered in this section may appear throughout the body of this manual where applicable.

### **WARNING**



#### **GROUNDING INSTRUCTIONS**

This product must be grounded. In the event of an electrical short circuit, grounding reduces the risk of electric shock by providing an escape wire for the electric current. This product is equipped with a cord having a grounding wire with an appropriate grounding plug. The plug must be plugged into an outlet that is properly installed and grounded in accordance with all local codes and regulations.

- Improper installation of the grounding plug is able to result in a risk of electric shock.
- This product is for use on a nominal 120 V circuit and has a grounding plug similar to the plugs illustrated in the figure below.

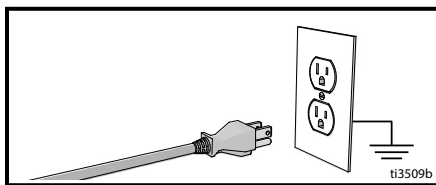

- Only connect the product to an outlet having the same configuration as the plug.
- Do not modify the plug provided. If it does not fit the outlet, have the proper outlet installed by a qualified electrician.
- Do not use a 3-to-2 adapter with this product.
- When repair or replacement of the cord or plug is required, do not connect the grounding wire to either power terminal.
- The wire with insulation having an outer surface that is green with or without yellow stripes is the grounding wire.
- Check with a qualified electrician or serviceman when the grounding instructions are not completely understood, or when in doubt as to whether the product is properly grounded.

#### **Extension Cords:**

- Use only a 3-wire extension cord that has a grounding plug and a grounding receptacle that accepts the plug on the product.
- Make sure your extension cord is not damaged.
- If an extension cord is necessary, use 12 AWG (2.5 mm<sup>2</sup>) minimum to carry the current that the product draws. An undersized cord results in a drop in line voltage and loss of power and overheating.

## ! WARNING



### FIRE AND EXPLOSION HAZARD

Flammable fumes, such as solvent and paint fumes, in work area can ignite or explode. To help prevent fire and explosion:



- Do not spray or clean with materials having flash points lower than 100°F (38°C). Use only non-flammable or water-based materials, or non-flammable paint thinners. For complete information about your material, request the Safety Data Sheets (SDSs) from the material distributor or retailer.
- Do not spray combustible materials near an open flame or sources of ignition such as cigarettes, motors, and electrical equipment.
- Paint or solvent flowing through the equipment is able to result in static electricity. Static electricity creates a risk of fire or explosion in the presence of paint or solvent fumes. All parts of the spray system, including the sprayer and objects in and around the spray area shall be properly grounded to protect against static discharge and sparks.
- Verify that all containers and collection systems are grounded to prevent static discharge. Do not use pail liners unless they are anti-static or conductive.
- Connect to a grounded outlet and use grounded extensions cords. Do not use a 3-to-2 adapter.
- **Stop operation immediately** if static sparking occurs or you feel a shock. Do not use equipment until you identify and correct the problem.
- Do not use a paint or a solvent containing halogenated hydrocarbons.
- Keep spray area well-ventilated. Keep a good supply of fresh air moving through the area.
- Sprayer generates sparks. Keep pump assembly in a well-ventilated when spraying, flushing, cleaning, or servicing.
- Do not smoke in the spray area or spray where sparks or flame is present.
- Do not operate light switches, engines, or similar spark producing products in the spray area.
- Keep area clean and free of paint or solvent containers, rags, and other flammable materials.
- Know the contents of the paints and solvents being sprayed. Read all Safety Data Sheets (SDSs) and container labels provided with the paints and solvents. Follow the paint and solvent manufacturer's safety instructions.
- Keep a working fire extinguisher in the work area.



### ELECTRIC SHOCK HAZARD

This equipment must be grounded. Improper grounding, setup, or usage of the system can cause electric shock.



- Turn off and disconnect power cord before servicing equipment.
- Connect only to grounded electrical outlets.
- Use only 3-wire extension cords.
- Ensure ground prongs are intact on power and extension cords.
- Do not expose to rain. Store indoors.

**! WARNING**



**SKIN INJECTION HAZARD**

High-pressure spray is able to inject toxins into the body and cause serious injury that can result in amputation. In the event that injection occurs, **get immediate surgical treatment.**



- Do not aim the gun at, or spray any person or animal.
- Keep hands and other body parts away from the discharge. For example, do not try to stop leaks with any part of the body.
- Always use the spray tip guard. Do not spray without spray tip guard in place.
- Use Graco spray tips.
- Use caution when cleaning and changing spray tips. In the case where the spray tip clogs while spraying, follow the **Pressure Relief Procedure** for turning off the unit and relieving the pressure before removing the spray tip to clean.
- Equipment maintains pressure after power is shut off. Do not leave the equipment energized or under pressure while unattended. Follow the **Pressure Relief Procedure** when the equipment is unattended or not in use, and before servicing, cleaning, or removing parts.
- Check parts for signs of damage. Replace any damaged parts.
- This system is capable of producing 2000 psi (138 bar, 13.8 MPa). Use Graco parts or accessories that are rated a minimum of 2000 psi (138 bar, 13.8 MPa).
- Verify that all connections are secure before operating the unit.
- Know how to stop the unit and bleed pressure quickly. Be thoroughly familiar with the controls.



**EQUIPMENT MISUSE HAZARD**

Misuse can cause death or serious injury.



- Always wear appropriate gloves, eye protection, and a respirator or mask when painting.
- Do not operate or spray near children. Keep children away from equipment at all times.
- Do not overreach or stand on an unstable support. Keep effective footing and balance at all times.
- Stay alert and watch what you are doing.
- Do not operate the unit when fatigued or under the influence of drugs or alcohol.
- Do not alter or modify equipment. Alterations or modifications may void agency approvals and create safety hazards.
- Make sure all equipment is rated and approved for the environment in which you are using it.

**! WARNING**



**PRESSURIZED ALUMINUM PARTS HAZARD**

Use of fluids that are incompatible with aluminum in pressurized equipment can cause serious chemical reaction and equipment rupture. Failure to follow this warning can result in death, serious injury, or property damage.

- Do not use 1,1,1-trichloroethane, methylene chloride, other halogenated hydrocarbon solvents or fluids containing such solvents.
- Do not use chlorine bleach.
- Many other fluids may contain chemicals that can react with aluminum. Contact your material supplier for compatibility.



**TOXIC FLUID OR FUMES HAZARD**

Toxic fluids or fumes can cause serious injury or death if splashed in the eyes or on skin, inhaled, or swallowed.

- Read Safety Data Sheets (SDSs) to know the specific hazards of the fluids you are using.
- Store hazardous fluid in approved containers, and dispose of it according to applicable guidelines.



**PERSONAL PROTECTIVE EQUIPMENT**

Wear appropriate protective equipment when in the work area to help prevent serious injury, including eye injury, hearing loss, inhalation of toxic fumes, and burns. Protective equipment includes but is not limited to:

- Protective eyewear, and hearing protection.
- Respirators, protective clothing, and gloves as recommended by the fluid and solvent manufacturer.



# Know Your Sprayer

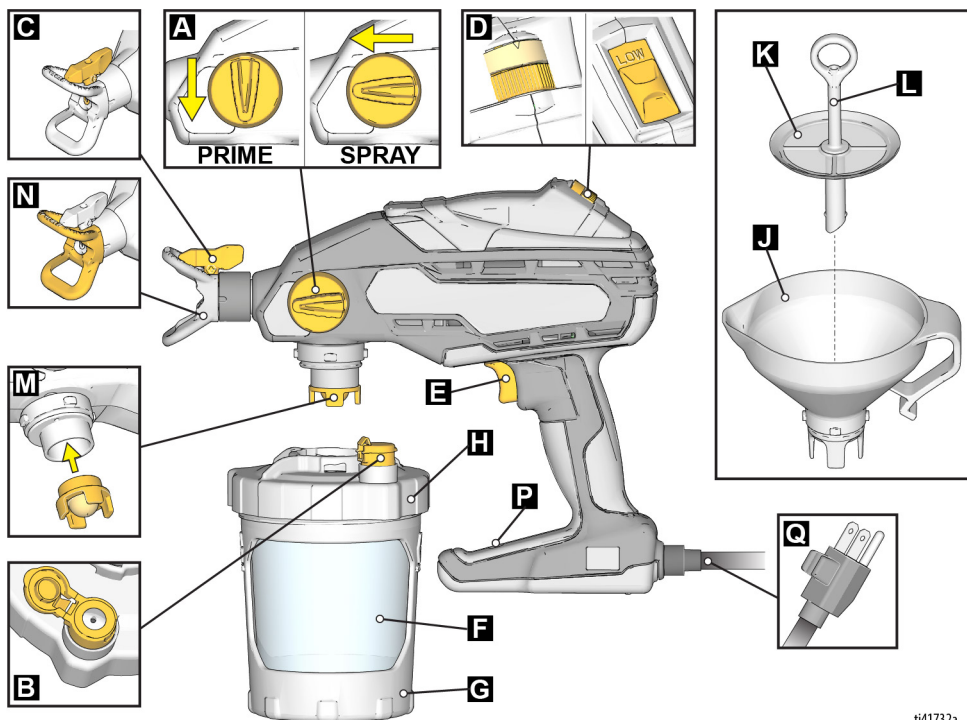

ti41732a

A	Prime Knob
B	VacuValve™
C	Spray Tip
D	Speed Control (available on select models only)
E	Trigger
F	FlexLiner™
G	Cup Support

H	Cup Lid
J	Funnel
K	Strainer
L	Strainer's Air Tube
M	Pump Filter
N	Spray Tip Guard
P	Spray Tip Holder
Q	Power Cord

# Know Your Controls

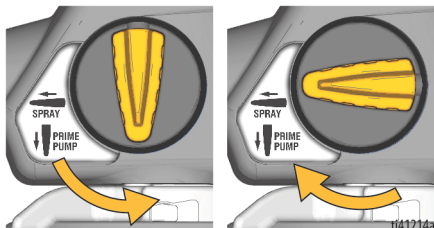

## Prime Knob

The Prime Knob directs fluid to either the cup or the Spray Tip. When priming, it is used to purge air from the pump. Your sprayer will not spray with air in the pump.

Turn Prime Knob down to PRIME position when priming the sprayer or to relieve system pressure.

Turn Prime Knob forward to SPRAY position to spray fluid.

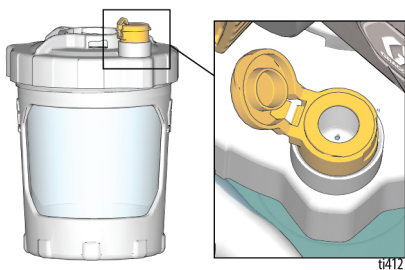

## VacuValve

The VacuValve is used to evacuate air out of the FlexLiner. This is necessary for the sprayer to prime.

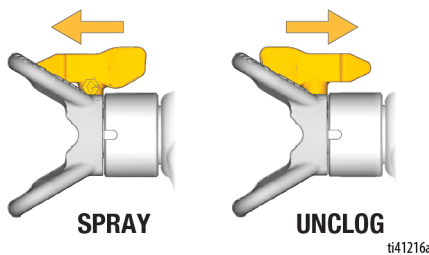

## Spray Tip

The Spray Tip is the key to airless spray technology. High pressure paint pumped through the very small hole in the Spray Tip comes out as a spray.

The Spray Tip has the ability to be reversed and quickly clear clogs.

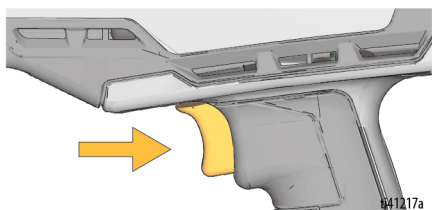

## Trigger

The Trigger controls the operation of the sprayer.

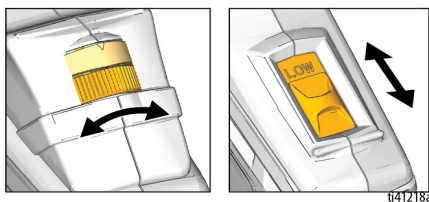

## Speed Control

The Speed Control\* allows you to slow down or speed up when spraying.

\*Available on select models only

# Setup

## Pressure Relief Procedure



Follow the Pressure Relief Procedure whenever you see this symbol.

--	--	--	--	--

This sprayer builds up an internal pressure of 2000 psi (138 bar, 13.8 MPa) during use. Follow this **Pressure Relief Procedure** whenever you stop spraying and before cleaning, checking, servicing, or transporting equipment to prevent serious injury.

1. Turn Prime Knob down to PRIME position to relieve pressure.

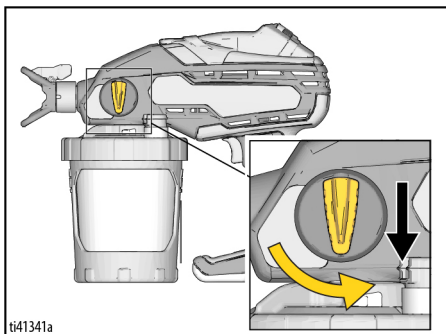

## Cup Fill



**Use only water-based or oil-based (mineral spirit-type) materials with a flash point greater than 100° F (38° C).**

Do not use materials which state "FLAMMABLE" on the packaging. For more information about your material, request a Safety Data Sheet (SDS) from distributor or retailer.

When spraying oil-based material, use outdoors or in a well-ventilated indoor area with a flow of fresh air.

**Keep spray area well-ventilated.** Keep a good supply of fresh air moving through the area.

If spraying **oil-based** materials, review **Fluid Compatibility**, page 21, and follow **Static Grounding Instructions (Oil-Based Materials)**, page 21.

1. Insert one FlexLiner into the Cup Support.

**NOTE:** Verify there is no damage to the top sealing edge of the FlexLiner, such as a crease or fold. If damaged it will leak air and lose prime.

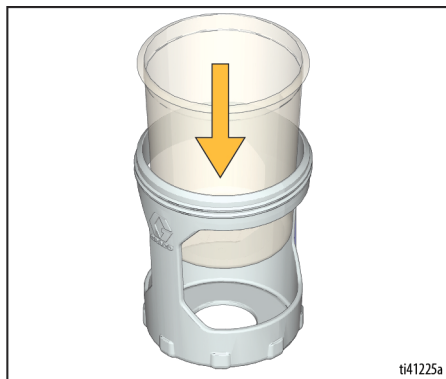

2. Firmly tighten the Cup Lid onto the Cup Support to ensure an airtight seal.

**NOTE:** To ensure an airtight seal, the gasket inside the Cup Lid is lubricated by the factory. If lubrication has washed away, apply Seal Lube (included) to the gasket.

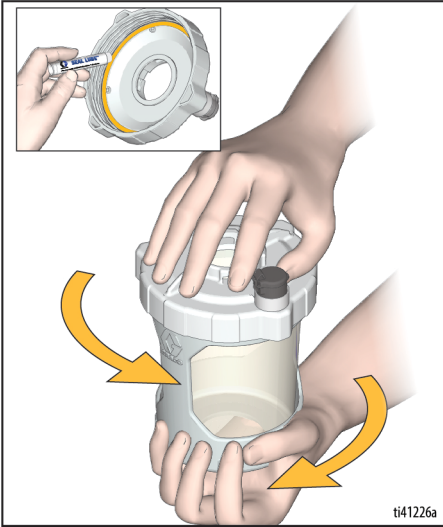

3. Insert the Funnel into the Cup Lid, twist to lock. Snap the Strainer into the Funnel to strain your paint as you fill your cup.

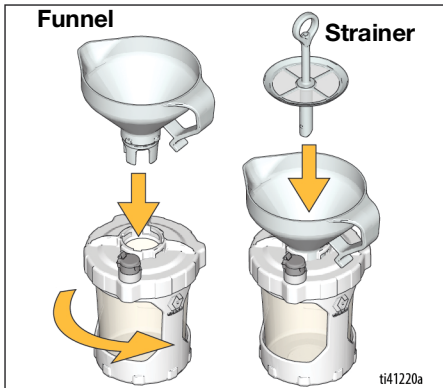

4. The Strainer's Air Tube will prevent paint from overflowing the cup. Fill the cup as follows:

- a. Watching the Funnel (not the cup), slowly pour paint into the Funnel. When the paint stops draining down, the cup is full.

**NOTE:** If the paint stops draining but you see the cup is not full, use a stir stick to scrape the captured debris on the top of the Strainer until the paint resumes draining.

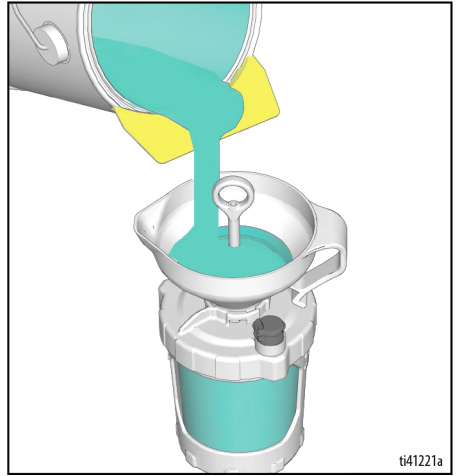

- b. With the Funnel and Strainer still attached to the cup, pour excess paint from the Funnel back into the paint can.

- d. Remove the Funnel and Strainer from the cup and hook on edge of paint can.

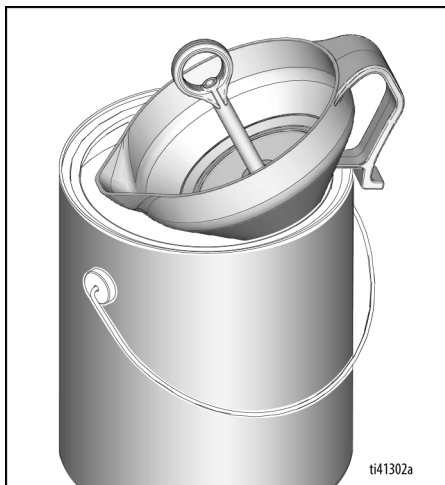
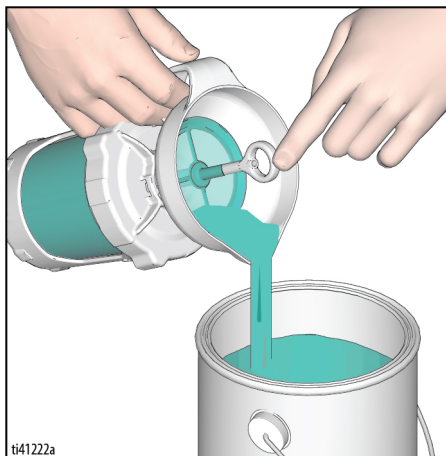

- c. Lift up the Strainer and look to verify you can see crossbars in the bottom of the Funnel. If not, the cup is overfilled. Pour excess paint back into the paint can.

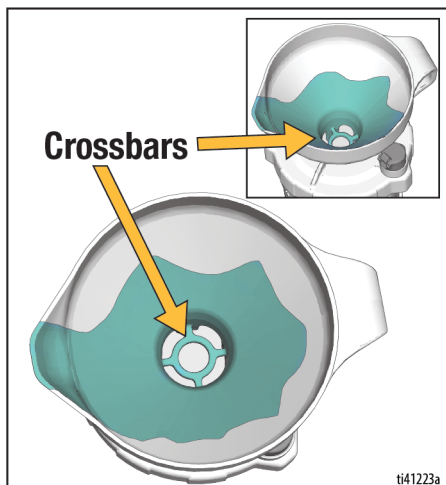

# Startup

1. Install the cup onto the sprayer as follows:
  - a. Verify Pump Filter is installed and clean.

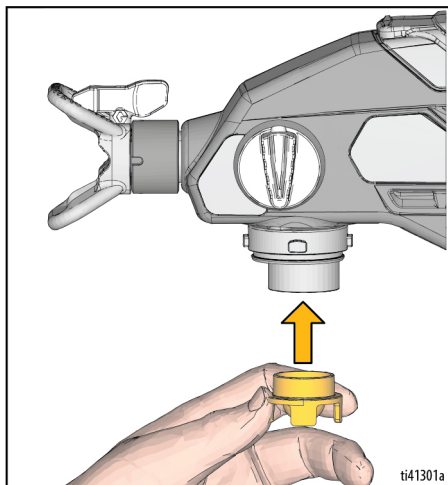

- b. Align VacuValve (on Cup Lid) with Prime Knob (on sprayer).
- c. Push cup assembly onto the sprayer, twist to lock.

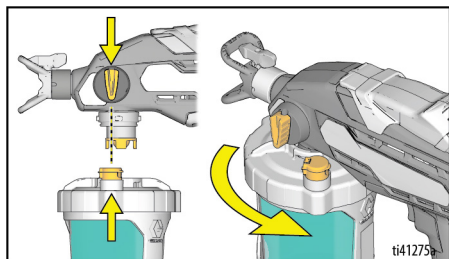

2. Prime the pump as follows:
  - a. Verify Prime Knob is pointed down to PRIME position.

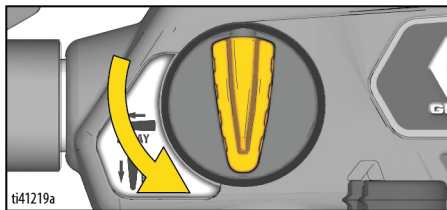

- b. Plug sprayer into a grounded power source.

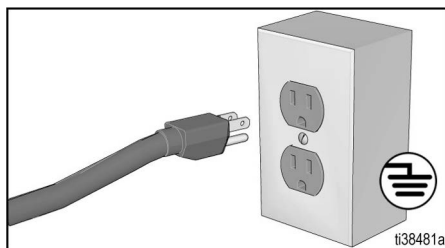

- c. Open the VacuValve cap and gently squeeze the FlexLiner until no more air bubbles appear in the VacuValve.

**NOTE:** Tilt the sprayer such that the VacuValve is the highest point so that all air in the FlexLiner can be fully evacuated.

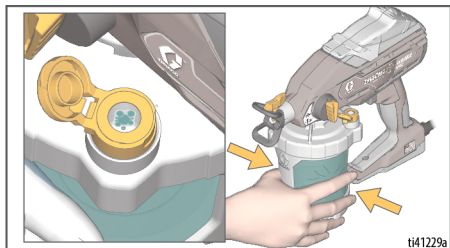

- d. Continue to squeeze the FlexLiner while pulling the Trigger for 10 seconds.

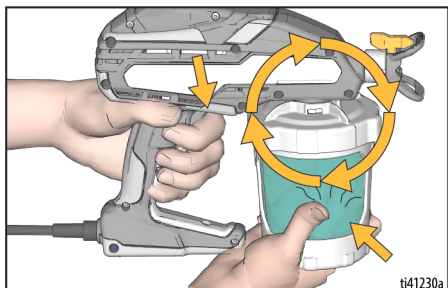

**NOTE:** This will purge all air from the pump and cup. Paint will not spray out, but will recirculate through the pump and back into the cup.

- e. When no more air bubbles appear in the VacuValve, release the Trigger and close the VacuValve cap.

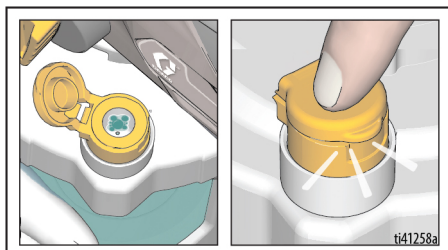

3. Turn Prime Knob forward to SPRAY position. Verify Spray Tip is forward in the SPRAY position.

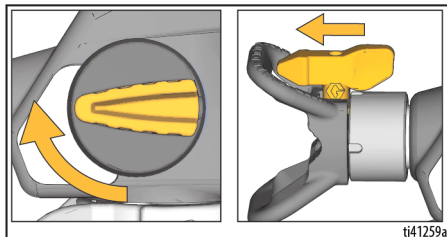

4. Point the sprayer into a waste pail and pull the Trigger for 5 seconds to spray out storage fluid.
- To avoid pump damage, if the sprayer does not spray after 5 seconds, STOP and repeat STARTUP.

## You are now ready to spray!

**NOTE:** For best results, to evacuate all material from the FlexLiner when the material is nearly gone, gently squeeze the bottom of the FlexLiner to push the last of the material up to the Cup Lid.

**IMPORTANT!** The motor has a built-in feature to protect itself from overuse. If the motor stops, the thermal switch has tripped. The motor will operate normally after cooling for 20-30 minutes.

# Spraying

--	--	--	--	--

**Use only water-based or oil-based (mineral spirit-type) materials with a flash point greater than 100° F (38° C).** Do not use materials which state “FLAMMABLE” on the packaging. For more information about your material, request a Safety Data Sheet (SDS) from distributor or retailer.

When spraying oil-based material, use outdoors or in a well-ventilated indoor area with a flow of fresh air.

**Keep spray area well-ventilated.** Keep a good supply of fresh air moving through the area.

1. Set the Speed Control to lowest available setting.

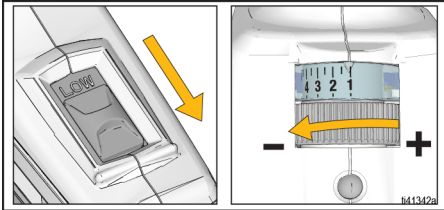

2. Pointing at a piece of scrap cardboard, pull the Trigger to test the spray pattern.
3. If needed, slowly increase the Speed Control to the setting that produces a good spray pattern.

**NOTE:** To minimize overspray, always spray at the lowest speed setting that gives a good spray pattern.

4. Adjust the sprayer’s distance from the surface and your hand speed to achieve the desired surface coverage.

# Spray Tip Orientation

--	--	--	--	--

To avoid serious injury from skin injection, do not put your hand in front of the Spray Tip when installing or removing the Spray Tip and Tip Guard.

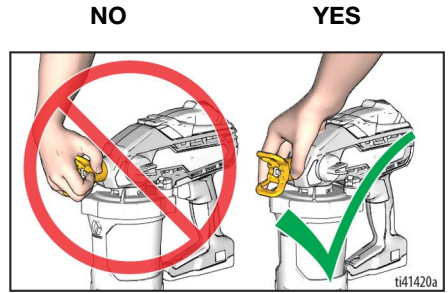

Adjust the Spray Tip Guard for the desired vertical or horizontal spraying direction.

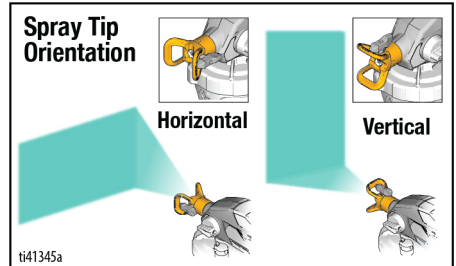



## Spray Pattern Quality

A good spray pattern is evenly distributed without voids or runs. Adjust sprayer Speed Control (if available), hand speed, and distance from the wall to get a good spray pattern.

If tails persist, material may need to be thinned. If material needs to be thinned, follow manufacturers recommendations.

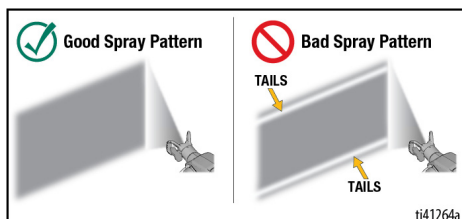

- Flex wrist to keep sprayer pointed straight. Fanning sprayer to direct spray at angle causes uneven finish.

**NOTE:** How fast you move the sprayer will affect spray application. If material is pulsating, you are moving too fast. If material drips, you are moving too slow. See **Troubleshooting**, page 26.

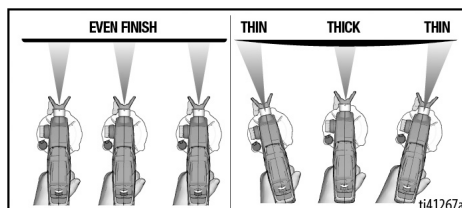

## Spray Angle

Use a piece of scrap cardboard to practice these basic spraying techniques before you begin spraying the surface.

- Hold sprayer 10-12 inches (25-30 cm) from surface and aim straight at surface. Tilting the sprayer to direct the spray angle causes an uneven finish.

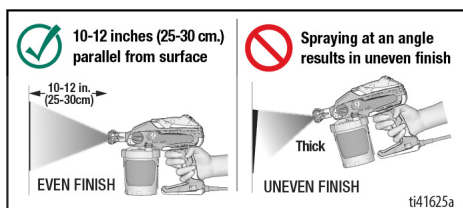

## Aiming Sprayer

Aim the sprayer at the bottom edge of the previous stroke, overlapping each stroke by 50%.

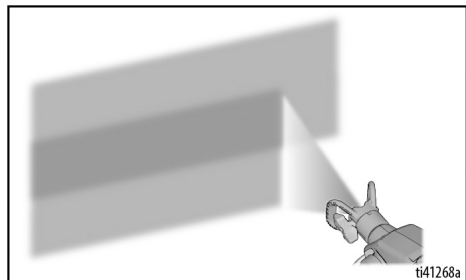

## Triggering Timing

Pull Trigger after starting stroke. Release Trigger before end of stroke. Sprayer must be moving when Trigger is pulled and released.

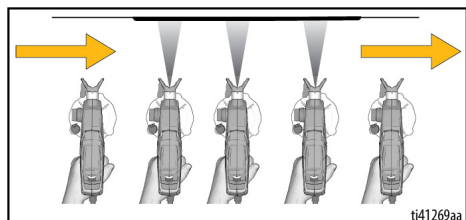

## Reversible Spray Tips

Your sprayer is shipped with wide and narrow reversible Spray Tips.

- **Blue Spray Tips** are for spraying *paint* and should be used with the blue Pump Filter.
- **Green Spray Tips** are for spraying *stain* and should be used with the green Pump Filter (green tips and filter are not included with all models).

## Spray Tip Removal



To avoid serious injury from skin injection, do not put your hand in front of the Spray Tip when installing or removing the Spray Tip and Tip Guard.

1. Turn Prime Knob down to PRIME position to relieve system pressure.
2. Rotate Spray Tip 90 degrees.
3. Pull the Spray Tip straight out of the Spray Tip Guard.

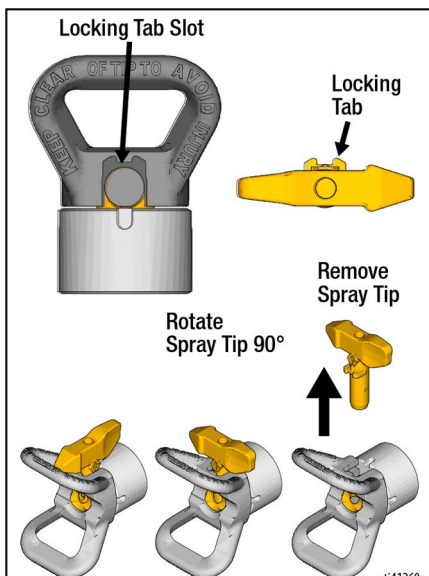

## Spray Tip Installation

1. Align Spray Tip locking tab with the locking tab slot in the Spray Tip Guard.
2. Push the Spray Tip all the way into the Spray Tip Guard.
3. Rotate the Spray Tip to the SPRAY position.

**NOTE:** Make certain the Spray Tip locking tab is pushed all the way into the slot in the Spray Tip Guard. You should not be able to remove the Spray Tip from the Spray Tip Guard when it is in the SPRAY or UNCLOG positions.

### NOTICE

The Spray Tip Guard is permanently attached to the sprayer. Removal will result in damage to the sprayer.



## Clear Tip Clogs



To avoid serious injury from skin injection, do not put your hand in front of the Spray Tip when installing or removing the Spray Tip and Tip Guard.

In the event debris clogs the Spray Tip, the sprayer is designed with a reversible Spray Tip that quickly and easily clears the particles without disassembling the sprayer.

1. Turn Prime Knob down to PRIME position to relieve system pressure.
2. Reverse Spray Tip to UNCLOG position.

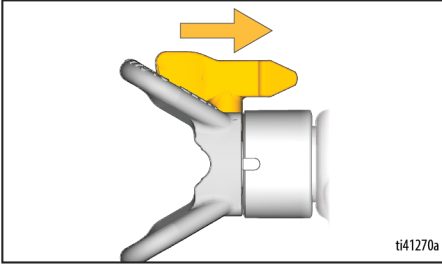

3. Set Speed Control to highest available setting.

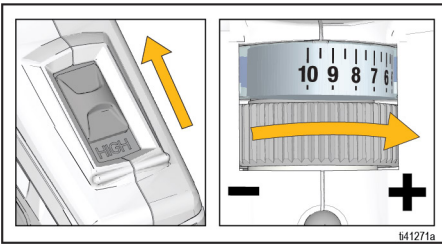

4. Point sprayer into waste pail, turn Prime Knob forward to SPRAY position. Pull Trigger for 5 seconds to clear clog.

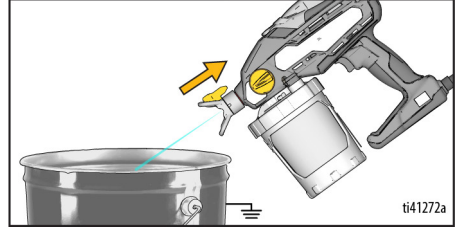

**NOTE:** If Spray Tip is still clogged, you may have to repeat steps 1-4, or replace with replacement Spray Tip.

5. Turn Prime Knob downward to PRIME position. Rotate Spray Tip back to SPRAY position. Turn Prime Knob forward to SPRAY position, and resume spraying.

## Cup Refills

1. Turn Prime Knob down to PRIME position to relieve system pressure.
2. Remove cup assembly from sprayer. Remove the Pump Filter and clean debris from the filter screen.

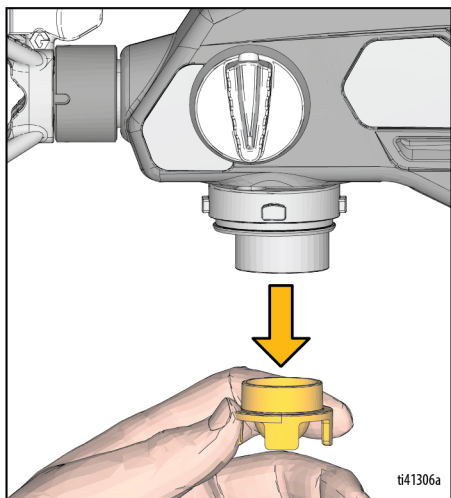

3. Reinstall the Pump Filter into the pump. Set sprayer on a rag.

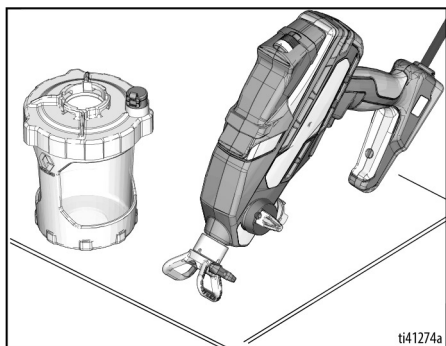

4. Refill the cup following **Cup Fill**, page 11, steps 3 and 4. Then follow **Startup**, page 14, instructions to proceed.

## Pause in Spraying

Paint will dry quickly and cause clogs in the sprayer. Follow these steps whenever you pause spraying for 5 minutes to 2 hours.

1. Turn Prime Knob down to PRIME position to relieve system pressure.
2. Unplug Power Cord.
3. Turn Spray Tip 90 degrees to seal orifice from drying out.

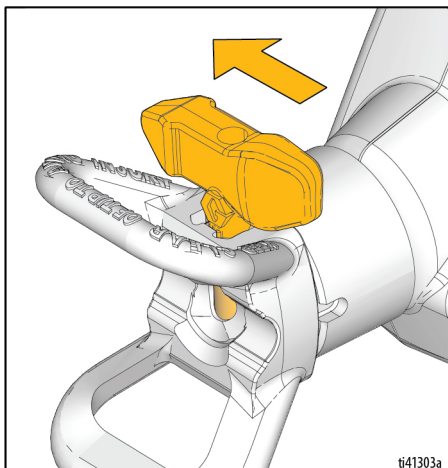

4. Ensure sprayer is fully sealed. Ensure VacuValve is closed and cup is attached to sprayer with all air evacuated.

## Cleanup



Use only **water-based** or **oil-based** (mineral spirit-type) materials with **flash point greater than 100° F (38° C)**. Do not use materials which state “**FLAMMABLE**” on the packaging. For more information about your material, request a Safety Data Sheet (SDS) from distributor or retailer.

**Clean in a well-ventilated area.** Keep a good supply of fresh air moving through the area.

To avoid serious injury or damage to equipment, do not expose the sprayer electronics to cleaning fluids. Keep sprayer **at least 10 in. (25 cm)** above the rim of the container when cleaning.

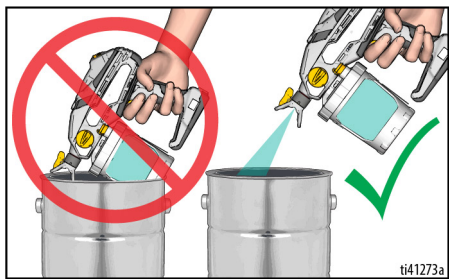

## Fluid Compatibility

### Oil or water-based materials

If spraying **water-based** materials, use water for cleanup. If spraying **oil-based** materials, use non-flammable mineral spirits for cleanup.

- Switching between **water-based** and **oil-based** materials can cause clogging issues in the sprayer. Always clean sprayer thoroughly with appropriate cleaning fluid.
- It is recommended to thoroughly flush the sprayer with non-flammable mineral spirits prior to using **oil-based**

## Static Grounding Instructions (Oil-Based Materials)



The equipment must be grounded to reduce the risk of static sparking and electric shock. An electric or static spark can cause fumes to ignite or explode. An improper ground can cause electric shock. A good ground provides an escape wire for the electric current.

Always use a metal pail for oil-based materials requiring flushing with compatible oil-based flushing solvents when sprayer is flushed or pressure is relieved.

Follow local code. Use only conductive metal pails, placed on a grounded surface such as concrete.

Do not place pail on a non-conductive surface such as paper or cardboard which interrupts grounding continuity.



## Cleaning Sprayer

Cleaning your sprayer properly and after every spray job is of the utmost importance! Proper care and maintenance will make your paint sprayer last and work for you trouble free.

1. Turn Prime Knob down to PRIME position to relieve system pressure.
2. Remove cup assembly from sprayer, and remove Pump Filter. Set sprayer on a rag.

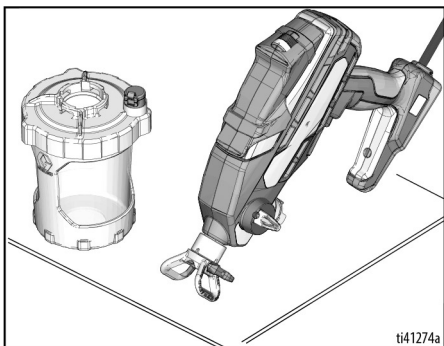

3. Remove Cup Lid and pour extra paint back into paint can. Clean all parts with warm water.

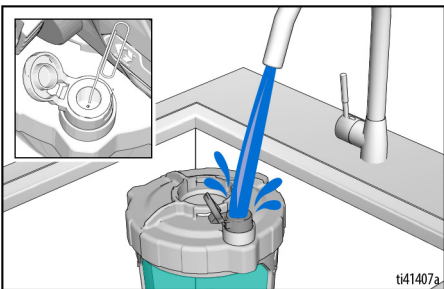

**NOTE:** Be sure to clean inside the VacuValve reservoir. If the VacuValve air hole becomes clogged, use a paper clip to clean hole.

4. To circulate cleaning fluid, fill clean cup assembly half-full of cleaning fluid and reattach to sprayer.
  - a. Verify the Prime Knob is pointed down to the PRIME position.
  - b. Set Speed Control to highest setting available.

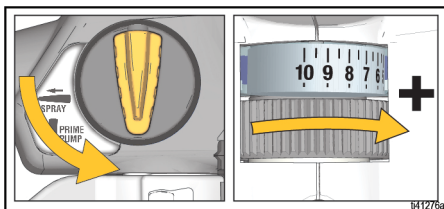

- c. Turn the sprayer upside down and trigger for 15 seconds.

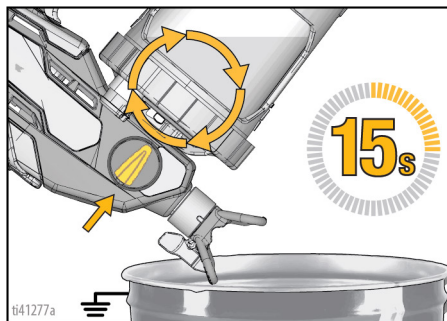

5. To spray cleaning fluid, refill cup assembly half-full of cleaning fluid and reattach to sprayer.
  - a. Turn the Prime Knob forward to SPRAY position and Spray Tip to the UNCLOG position.
  - b. Turn the sprayer upside down and trigger into a waste pail for 15 seconds.

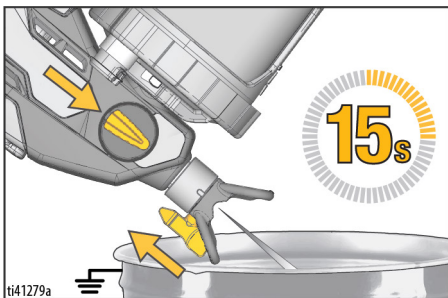

- c. Turn the Spray Tip to the SPRAY position and trigger into a waste pail for 15 seconds.

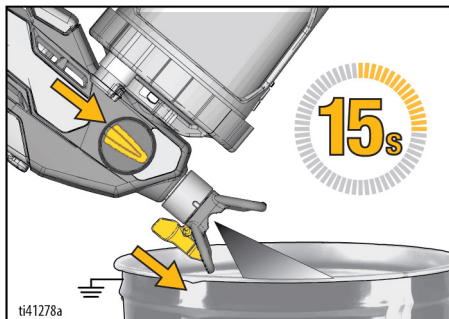

6. Repeat Cleanup steps as needed until sprayer is clean.
7. Turn Prime Knob down to PRIME position.
8. Unplug Power Cord.
9. Remove Spray Tip from Spray Tip Guard.
10. Clean Spray Tip, Spray Tip Guard, and Pump Filter with warm water and an old toothbrush. Reinstall Spray Tip and Pump Filter.

# Storage

## NOTICE

Failure to store sprayer with Pump Armor™ will result in operational problems the next time you spray. Always fill the sprayer with Pump Armor after cleaning. **Water left in the sprayer will corrode and damage the pump.**

Pump Armor fluid protects the sprayer while in storage. It helps protect sprayer against startup issues on next use.

- Do not store the sprayer full of water.
- Do not allow water to freeze in sprayer.
- Do not store sprayer under pressure.
- Store sprayer indoors in a cool, dry location.
- Never store sprayer with material in the sprayer or cup.

1. Clean the sprayer and cup assembly. See **Cleanup**, page 21.
2. Turn Prime Knob downward to PRIME position.

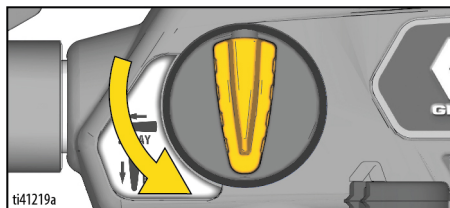

3. Remove cup assembly from sprayer and remove Pump Filter from pump.
4. Turn Prime Knob forward to SPRAY position and Spray Tip to the UNCLOG position.

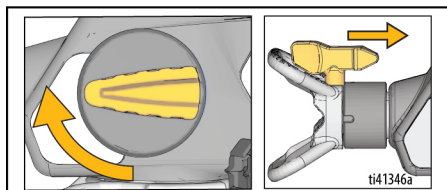

5. With the sprayer upside down, pour approximately 2 oz. (60 ml) Pump Armor (included) into pump opening.

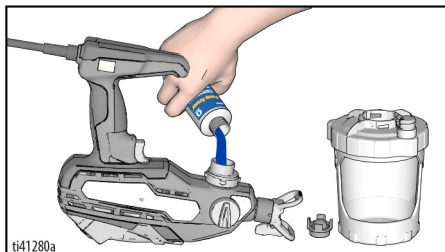

6. Install clean Pump Filter into pump.
7. Keep sprayer upside down and attach cup assembly on to the sprayer.
8. With the sprayer remaining upside down over a waste pail, pull the Trigger until fluid first comes out of the Spray Tip and then immediately let go of the Trigger (approx. 1 second).

**NOTE:** Do not spray out all fluid. Pump is now loaded with Pump Armor for storage.

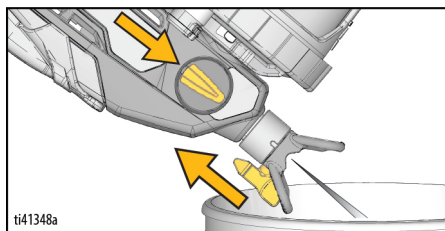

9. Turn Prime Valve to PRIME position to relieve system pressure and immediately back to SPRAY position for storage. Unplug Power Cord.
10. Replace child-resistant cap on Pump Armor bottle and tighten securely for next use.



## Recycling and Disposal

### End of Product Life

At the end of the product's useful life, dismantle and recycle it in a responsible manner.

- Turn Prime Knob down to PRIME position to relieve system pressure.
- Drain and dispose of fluids according to applicable regulations. Refer to the material manufacturer's Safety Data Sheet.

- Remove motors, batteries, circuit boards, LCDs (liquid crystal displays), and other electronic components. Recycle according to applicable regulations.

- Do not dispose of electronic components with household or

commercial waste. 

- Deliver remaining product to a recycling facility.

# Troubleshooting



**QUESTIONS?**  
**888-541-9788**  
graco.com/HomeownerSupport





Check everything in this Troubleshooting Table before you bring the sprayer to an authorized service center.

## Sprayer Diagnostics

Problem	Cause	Solution
Sprayer makes sound but no material is sprayed when Trigger is pulled	Spray Tip is clogged	See <b>Clear Tip Clogs</b> , page 19.
	Sprayer is not primed	Repeat <b>Start Up</b> procedure to ensure all air is evacuated from the FlexLiner. See <b>Startup</b> , page 14.
		Verify Cup Lid is tight. An under tightened Cup Lid will allow air to seep into the FlexLiner and cause a loss of prime. Add Seal Lube (included) to the Cup Lid gasket to ensure an airtight seal.
		If the sprayer sprays when upside down by not upright, there is likely still an air leak into the cup. Try replacing the FlexLiner and VacuValve (extra of both included with sprayer).
		Make certain there is only one FlexLiner in the Cup Support.
		Make certain there is no damage to or debris on the top sealing edge of the FlexLiner or Cup Lid gasket.
		Make certain all the air is out of the FlexLiner and the VacuValve cap is properly closed.
		Make certain the cup assembly is properly installed onto the sprayer.
Clean sprayer. See <b>Cleanup</b> , page 21.		
Pump Filter is plugged	Remove the Pump Filter from the pump. Clean both sides of the Pump Filter. While the Pump Filter is removed, inspect and ensure no dried paint debris is collected inside the pump inlet.	
Prime Knob is in PRIME position	Turn Prime Knob forward to SPRAY position.	
Spray Tip is not in SPRAY position	Turn Spray Tip to SPRAY position.	
No or low material in FlexLiner	Refill FlexLiner. See <b>Cup Fill</b> ,	

Problem	Cause	Solution
Sprayer makes no sound when Trigger is pulled	Power supply	Make certain the sprayer is plugged into a grounded and functional power source.
	Motor has overheated	Wait 20-30 minutes for motor to cool.
	Electronic control failure	Replace electronic control.
Sprayer sprays with poor results	Spray Tip is partially clogged	See <b>Clear Tip Clogs</b> , page 19.
	Spray Tip is not in correct position	See <b>Spray Tip Installation</b> , page 18.
	Incorrect Spray Tip for application of material	Install a different size Spray Tip. See <b>Reversible Spray Tips</b> , page 18.
	Spray Tip is worn or damaged	Replace Spray Tip.
	Material being sprayed is aerated and full of bubbles	Let material settle or change to different material.
	Material being sprayed is too cold	Warm material.
Paint leaks from sprayer	Pump has reached its maximum life	Replace pump.
Paint leaks out of the cup threads	Cup not properly seated	Verify Cup Lid is tight. An under tightened Cup Lid will allow air to seep into the FlexLiner and cause a loss of prime. Add Seal Lube (included) to the Cup Lid gasket to ensure an airtight seal.
		Make certain there is only one FlexLiner in the Cup Support.
		Make certain there is no damage to or debris on the top sealing edge of the FlexLiner or Cup Lid gasket.
		Make certain the Cup Lid is properly threaded to the Cup Support. There should be no threads visible when tight.
		Avoid flexing or pushing on the Cup Support when you evacuate the air out of the FlexLiner.
		Avoid pulling down on the FlexLiner when you evacuate the air out of the FlexLiner.
		Replace FlexLiner.

## Spray Pattern Diagnostics

Problem	Cause	Solution
Spray pattern is pulsating: 	Operator is moving too fast while spraying	Slow speed of movement.
	Spray Tip is clogged	See <b>Clear Tip Clogs</b> , page 19.
	Material is difficult to atomize	On models with Speed Control, increase speed until desired pattern is achieved. See <b>Spraying</b> , page 16.
	Sprayer is too far from target surface	Hold sprayer farther away from surface. See <b>Spraying</b> , page 16.
	Incorrect Spray Tip for application of material	Install a different size Spray Tip. See <b>Reversible Spray Tips</b> , page 18.
Spray pattern has tails: 	Speed Control is set too low	On models with Speed Control, increase speed until desired pattern is achieved. See <b>Spraying</b> , page 16.
	Incorrect Spray Tip for application of material	Install a different size Spray Tip. See <b>Reversible Spray Tips</b> , page 18.
	Material may need to be thinned	Thin material following paint manufacturer's recommendations.
	Material not compatible with sprayer	Change to different material.
	Spray Tip is worn or damaged	Replace Spray Tip.
Spray pattern has dripping/sagging: 	Operator is moving too slowly while spraying	Move sprayer faster when spraying.
	Sprayer is too close to target surface	Move sprayer away from surface. See <b>Spraying</b> , page 16.
	Holding Trigger while changing spray direction	Release Trigger when changing directions. See <b>Spraying</b> , page 16.
	Speed Control is set too high	On models with Speed Control, decrease speed until desired pattern is achieved. See <b>Spraying</b> , page 16.
	Spray Tip is worn or damaged	Replace Spray Tip.

Problem	Cause	Solution
Spray pattern "spits" at the end or beginning:  ti15525a	Excess material has accumulated on Spray Tip and Spray Tip Guard, or Spray Tip is partially plugged	Clean Spray Tip and Spray Tip Guard. Clear Spray Tip. See <b>Clear Tip Clogs</b> , page 19.
	Spray Tip is not fully inserted into Spray Tip Guard	See <b>Spray Tip Installation</b> , page 18.
	Spray Tip is worn or damaged	Replace Spray Tip.
	Pump has reached its maximum life	Replace pump.

# Replacement Parts

## Single Speed, Dual Speed, Dual Speed Premium

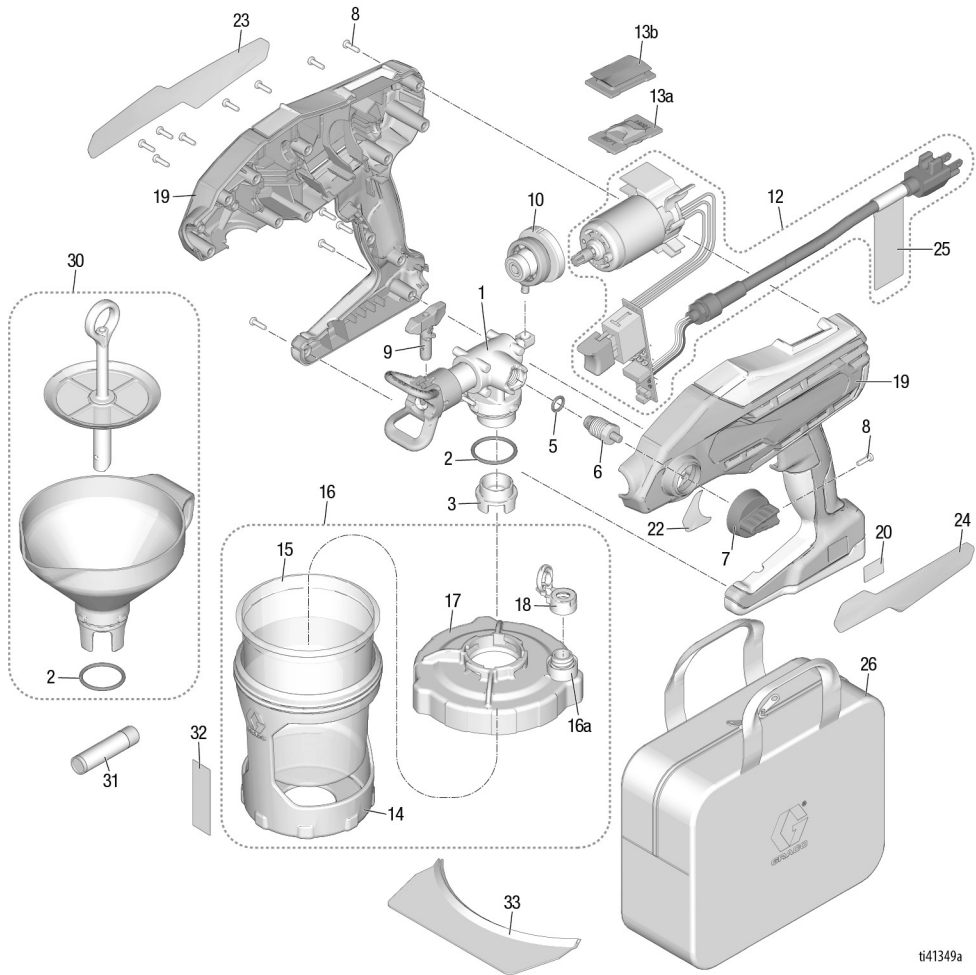

ti41349a

## Parts List- Single Speed, Dual Speed, Dual Speed Premium

Ref.	Sprayer Name	Order Part No.	Description
1	All	18F756	Complete pump assembly <i>includes 2, 3, 5, 6, 7, 8</i>
2	All	16Y425	O-ring
3	All	18A886	Filter, pump, paint
		18F209	Filter, pump, stain
5	All	117059	O-ring
6	All	17A402	Prime Pump/Spray valve <i>includes qty. 1 of ref. 5</i>
7	All	17A221	Kit, Prime Pump/Spray knob <i>includes qty. 1 of ref. 8</i>
8	All	119236	Screw, T-15 (torque 8-10 in-lb / 0.9-1.1 N•m)
9	All	18F520	Kit tips, paint <i>includes 3 (CAN models order CANP20)</i>
		18F519	Kit tips, stain <i>includes 3 (CAN models order CANS19)</i>
10	All	16X880	Reciprocator assembly
12	Single Speed	17A224	Control, electronic, single speed, 120V <i>includes motor, air duct, power cord and switch</i>
	Dual Speed	17B653	Control, electronic, dual speed, 120V <i>includes motor, air duct, power cord and switch</i>
13a	Dual Speed	16X868	Switch, dual speed control
13b	Single Speed	16X869	Plug, single speed
14	All	16W846	Support, 32 oz. cup
15	All	17A226	Kit, 32oz., FlexLiner (3-pack)
16	All	17R821	Kit, cup assembly <i>includes 14, qty. 1 of ref. 15, 16a, 17, qty. 1 of ref. 18</i>
16a	All	17M879	Plug, cup lid, not shipped with sprayer (not shown)
17	All	18F759	Lid, cup <i>includes qty. 1 of ref. 18</i>
18	All	17P712	VacuValve cap, 3-pack
19	All	17A227	Kit, enclosure <i>includes qty. 13 of ref. 8</i>
20	All	16Y680	Label, USA
22	All	16Y678	Label, control
23 ▲	All	16Y636	Label, warning and model number, side (not shown)
24	Single Speed	18C037	Label, brand, TrueCoat 360
	Dual Speed Premium	18C038	Label, brand, TrueCoat 360 DSP
	Dual Speed	18C040	Label, brand, TrueCoat 360 DS
25 ▲	All models	17A198	Label, warning, cord (not shown)
26	Dual Speed Premium	18F449	Case, storage
30	All	18B057	Kit, funnel, strainer <i>includes qty. 1 of ref. 2</i>
31	All	25T467	Lubricant, seal lube
32	All	17K515	Label, A+ Service (not shown)
33	All	18B058	Spout, pour
-- ▲	All	179960	Label, medical alert card (not shown)
---	All	243104	Pump Armor, 32 oz. (not shown)
---	All	18C045	Tag, hang, tip (not shown) (CAN models order 18F613)
---	All	17F518	Kit, 42 oz. cup (not shown)
---	All	17F005	Kit, 42 oz. FlexLiner (3-pack) (not shown)

▲ Replacement safety labels, tags, and cards are available at no cost.

# Replacement Parts

## Variable Speed Premium

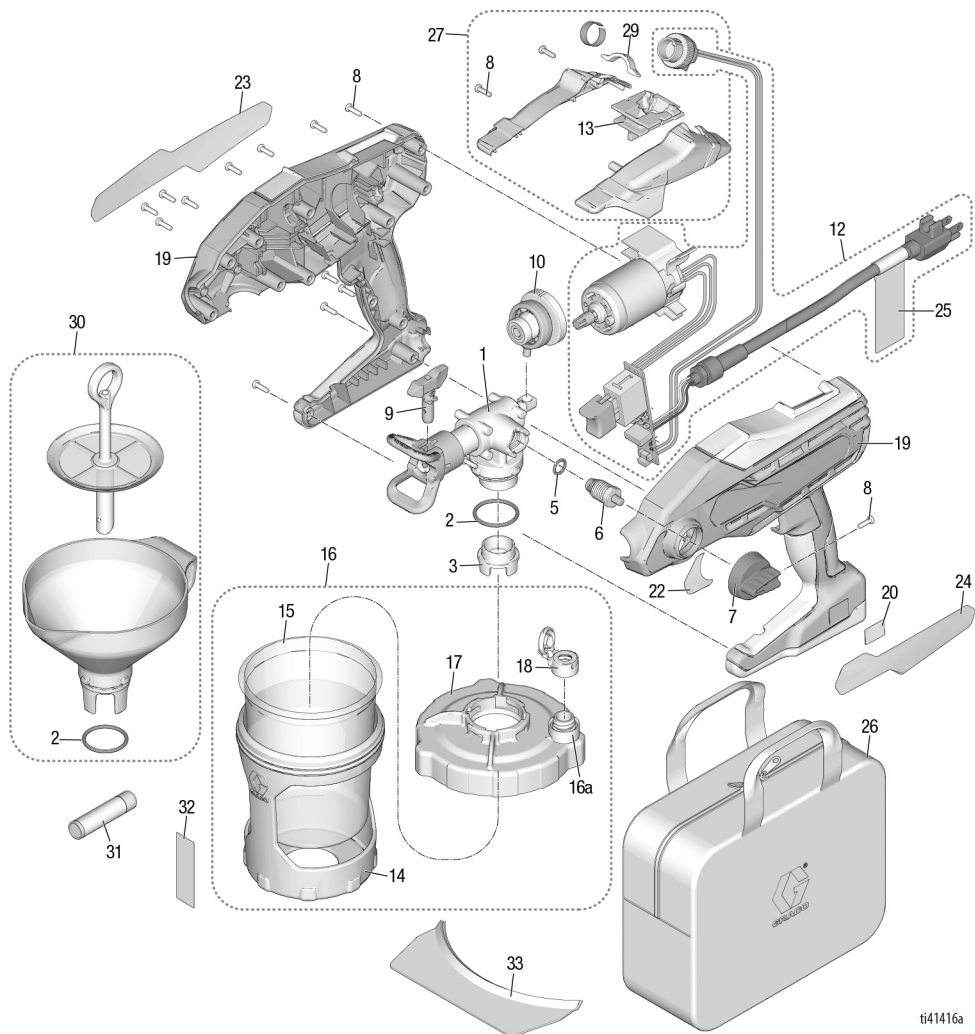

ti41416a



**Parts List- Variable Speed Premium**

Ref.	Sprayer Name	Order Part No.	Description
1	All	18F756	Complete pump assembly <i>includes 2, 3, 5, 6, 7, 8</i>
2	All	16Y425	O-ring
3	All	18A886	Filter, pump, paint
		18F209	Filter, pump, stain
5	All	117059	O-ring
6	All	17A402	Prime Pump/Spray valve <i>includes qty. 1 of ref. 5</i>
7	All	17A221	Kit, Prime Pump/Spray knob <i>includes qty. 1 of ref. 8</i>
8	All	119236	Screw, T-15 (torque 8-10 in-lb / 0.9-1.1 N•m)
9	All	18F520	Kit tips, paint <i>includes 3 (CAN models order CANP20)</i>
		18F519	Kit tips, stain <i>includes 3 (CAN models order CANS19)</i>
10	All	16X880	Reciprocator assembly
12	All	17F068	Control, electronic, variable speed, 120 V <i>includes motor, air duct, power cord and switch</i>
13	All	17D844	Adapter, variable speed control
14	All	16W846	Support, cup, 32 oz.
15	All	17A226	Kit, 32 oz., FlexLiner (3-pack)
16	All	17R821	Kit, cup assembly <i>includes 14, qty. 1 of ref. 15, 16a, 17, qty. 1 of ref. 18</i>
16a	All	17M879	Plug, cup lid, not shipped with sprayer (not shown)
17	All	18F759	Lid, cup <i>includes qty. 1 of ref. 18</i>
18	All	17P712	VacuValve cap, 3-pack
19	All	17A227	Kit, enclosure <i>includes qty. 13 of ref. 8</i>
20	All	16Y680	Label, USA
22	All	16Y678	Label, control
23 ▲	All	16Y636	Label, warning and model number, side (not shown)
24	All	18C042	Label, brand, TrueCoat 360 VSP
25 ▲	All	17A198	Label, warning, cord (not shown)
26	All	18F449	Case, storage
27	All	17F069	Kit, enclosure, variable speed <i>includes sight glass, includes 13, 29, qty. 2 of ref 8</i>
29	All	17D843	Sight glass
30	All	18B057	Kit, funnel, strainer <i>includes qty. 1 of ref. 2</i>
31	All	25T467	Lubricant, seal lube
32	All	17K515	Label, A+ Service (not shown)
33	All	18B058	Spout, pour
-- ▲	All	179960	Label, medical alert card (not shown)
---	All	243104	Pump Armor, 32 oz (not shown)
---	All	18C045	Tag, hang, tip (not shown) (CAN models order 18F613)
---	All	17F518	Kit, 42 oz. cup (not shown)
---	All	17F005	Kit, 42 oz. FlexLiner (3-pack) (not shown)

▲ Replacement safety labels, tags, and cards are available at no cost.

# Technical Specifications

TrueCoat 360		
	U.S.	Metric
Max Working Pressure	2000 psi	13.8 MPa, 138 bar
Maximum Amperage	2.5 Amps	2.5 Amps
Weight		
TrueCoat 360, 360 DS/DSP	3.5 lb (18 in.cord)	1.6 kg (45 cm cord)
TrueCoat 360 VSP	3.75 lb (18 in.cord)	1.7 kg (45 cm cord)
Dimensions:		
Length (All models)	12.50 in.	31.75 cm
Width (All models)	5.25 in.	13.34 cm
Height 360, 360 DS/DSP	9.75 in.	24.77 cm
Height 360 VSP	11.8 in.	29.97 cm
Storage Temperature Range ♦♦	32° to 113° F	0° to 45° C
Operating Temperature Range ✓	40° to 90° F	4° to 32° C
Storage Humidity Range	0% to 95% relative humidity, non-condensing	
Electrical Power Requirement	120 Vac, 60 Hz, 15A, 1 phase	
Duty Cycle	2/2 minutes	
Maximum tip orifice	0.015 in.	0.38 mm
Wetted materials on all models:	stainless steel, brass, polyethylene, carbide, nylon, polypropylene, fluoroelastomer, acetal, aluminum	

♦ Pump damage will occur if fluid freezes in pump.

♦ Damage to plastic parts may result if impact occurs in low temperature conditions.

✓ Changes in paint viscosity at very low or very high temperatures can affect sprayer performance.

## California Proposition 65

### CALIFORNIA RESIDENTS

**⚠ WARNING:** Cancer and reproductive harm –

## Graco Standard Warranty

Graco warrants all equipment referenced in this document which is manufactured by Graco and bearing its name to be free from defects in material and workmanship on the date of sale to the original purchaser for use. With the exception of any special, extended, or limited warranty published by Graco, Graco will, for a period of twelve months from the date of sale, repair or replace any part of the equipment determined by Graco to be defective. This warranty applies only when the equipment is installed, operated and maintained in accordance with Graco's written recommendations.

This warranty does not cover, and Graco shall not be liable for general wear and tear, or any malfunction, damage or wear caused by faulty installation, misapplication, abrasion, corrosion, inadequate or improper maintenance, negligence, accident, tampering, or substitution of non-Graco component parts. Nor shall Graco be liable for malfunction, damage or wear caused by the incompatibility of equipment with structures, accessories, equipment or materials not supplied by Graco, or the improper design, manufacture, installation, operation or maintenance of structures, accessories, equipment or materials not supplied by Graco.

This warranty is conditioned upon the prepaid return of the equipment claimed to be defective to an authorized Graco distributor for verification of the claimed defect. If the claimed defect is verified, Graco will repair or replace free of charge any defective parts. The equipment will be returned to the original purchaser transportation prepaid. If inspection of the equipment does not disclose any defect in material or workmanship, repairs will be made at a reasonable charge, which charges may include the costs of parts, labor, and transportation.

**THIS WARRANTY IS EXCLUSIVE, AND IS IN LIEU OF ANY OTHER WARRANTIES, EXPRESS OR IMPLIED, INCLUDING BUT NOT LIMITED TO WARRANTY OF MERCHANTABILITY OR WARRANTY OF FITNESS FOR A PARTICULAR PURPOSE.**

Graco's sole obligation and buyer's sole remedy for any breach of warranty shall be as set forth above. The buyer agrees that no other remedy (including, but not limited to, incidental or consequential damages for lost profits, lost sales, injury to person or property, or any other incidental or consequential loss) shall be available. Any action for breach of warranty must be brought within two (2) years of the date of sale.

**GRACO MAKES NO WARRANTY, AND DISCLAIMS ALL IMPLIED WARRANTIES OF MERCHANTABILITY AND FITNESS FOR A PARTICULAR PURPOSE, IN CONNECTION WITH ACCESSORIES, EQUIPMENT, MATERIALS OR COMPONENTS SOLD BUT NOT MANUFACTURED BY GRACO.** These items sold, but not manufactured by Graco (such as electric motors, switches, hose, etc.), are subject to the warranty, if any, of their manufacturer. Graco will provide purchaser with reasonable assistance in making any claim for breach of these warranties.

In no event will Graco be liable for indirect, incidental, special or consequential damages resulting from Graco supplying equipment hereunder, or the furnishing, performance, or use of any products or other goods sold hereto, whether due to a breach of contract, breach of warranty, the negligence of Graco, or otherwise.

### FOR GRACO CANADA CUSTOMERS

The Parties acknowledge that they have required that the present document, as well as all documents, notices and legal proceedings entered into, given or instituted pursuant hereto or relating directly or indirectly hereto, be drawn up in English. Les parties reconnaissent avoir convenu que la rédaction du présente document sera en Anglais, ainsi que tous documents, avis et procédures judiciaires exécutés, donnés ou intentés, à la suite de ou en rapport, directement ou indirectement, avec les procédures concernées.

**TO PLACE AN ORDER**, contact your Graco distributor or call 1-888-541-9788 to identify the nearest distributor.

*All written and visual data contained in this document reflects the latest product information available at the time of publication. Graco reserves the right to make changes at any time without notice.*

Original instructions. This manual contains English. MM 3A9014

**Graco Headquarters:** Minneapolis  
**International Offices:** Belgium, China, Japan, Korea

**GRACO INC. AND SUBSIDIARIES • P.O. BOX 1441 • MINNEAPOLIS MN 55440-1441 • USA**  
**Copyright 2022, Graco Inc. All Graco manufacturing locations are registered to ISO 9001.**