

K SINGLE-IMPELLER

SINGLE-IMPELLER ELECTRIC PUMPS



TECHNICAL DATA

Operating range:

from 1,8 to 96 m³/h, with head up to 62 metres.

Pumped liquid: clean, free of solids and abrasives, non-viscous, non-aggressive, non-crystallised and chemically neutral, with properties similar to water.

Liquid temperature range:

K 20/41, K 30/70, K 30/100, K 36/100

K 12/200, K 36/200, K 40/200 : from -10 °C to +50 °C

Remainder of the range: from -15 °C to +110 °C

Maximum ambient temperature: +40°C

Maximum operating pressure:

K 20/41, K 30/70, K 30/100, K 36/100, K 12/200, K 14/400 : 6 bar (600 kPa)

K 36/200, K 40/200, K 55/200, K 11/500, K 18/500, K 28/500 : 8 bar (800 kPa)

K 40/400, K 50/400, K 30/800, K 40/800, K 50/800,

K 20/1200, K 25/1200, K 35/1200 : 10 bar (1000 kPa)

Protection class:

IP 44 (IP 55 for 2,2 - 3 - 4 - 5,5 - 7,5 - 9,2 - 11 kW motors)

Protection class at the terminal board: IP 55

Insulation class: F

Standard voltage:

single-phase 220-240 V / 50 Hz

three-phase 230-400 V / 50 Hz up to 4 kW included - 400 V Δ 50 Hz from 5,5 kW

Installation: horizontal or vertical position, provided that the motor is always above the pump.

Special executions on requests: alternative voltages and frequencies.

APPLICATIONS

Single-impeller centrifugal pump suitable for domestic, civil, industrial and agricultural systems, and for decanting, mixing and irrigation uses.

CONSTRUCTION FEATURES OF THE PUMP

Pump body and motor support in cast iron.

Technopolymer or cast iron impeller, as per the TECHNICAL DATA table.

Carbon/ceramic mechanical seal.

CONSTRUCTION FEATURES OF THE MOTOR

Closed asynchronous type, external ventilation cooling.

Rotor running on ball bearings, oversized to ensure low noise and durability.

Standard built-in thermo-amperometric protection. Capacitor permanently fitted on single phase versions.

For the protection of the three-phase motor, we recommend the use of remote overload cut-outs, in compliance with current local regulations.

Construction according to CEI 2-3.

IE2 motors as standard, from 0,75 kW to 5,5 kW - IE3 ≥ 7,5 kW

K SINGLE-IMPELLER

SINGLE-IMPELLER ELECTRIC PUMPS

MATERIALS

No.	PARTS*	MATERIALS	MODELS
1	PUMP BODY	CAST IRON 200 UNI ISO 185	
3	SUPPORT	CAST IRON 200 UNI ISO 185	
4	IMPELLER	TECHNOPOLYMER A	20/41; K 30/70; K 30/100; K 36/100; K 12/200; K 36/200; K 40/200;
		TECHNOPOLYMER B	K 55/200
		CAST IRON 200 UNI ISO 185	K 14/400; K 11/500; K 18/500; K 28/500; K 40/400; K 50/400; K 30/800; K 40/800; K 50/800; K 20/1200; K 25/1200; K 35/1200;
7	SHAFT WITH ROTOR	AISI 416 STAINLESS STEEL X12CRS13 UNI 6900/71	K 20/41; K 30/70; K 12/200
		AISI 303 STAINLESS STEEL X10CRNIS 1089 UNI 6900/71	K 30/100; K 36/100; K 36/200; K 40/200; K 55/200; K14/400; K 11/500; K 18/500; K 28/500
		AISI 304 STAINLESS STEEL X5CRNI 1810 UNI 6900/71	K 40/400; K 50/400; K 30/800; K 40/800; K 50/800; K 20/1200; K 25/1200; K 35/1200;
16	MECHANICAL SEAL	CARBON / CERAMIC	
28	OR RING	NBR RUBBER	
		EPDM RUBBER	K 36/200; K 40/200; K 55/200; K 14/400; K 11/500; K 18/500; K 28/500; K 30/800; K 40/800; K 50/800; K 20/1200; K 25/1200; K 35/1200;

* In contact with the liquid

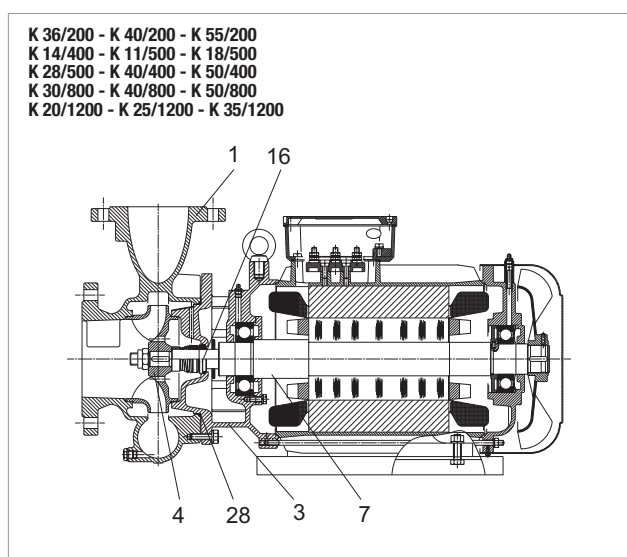
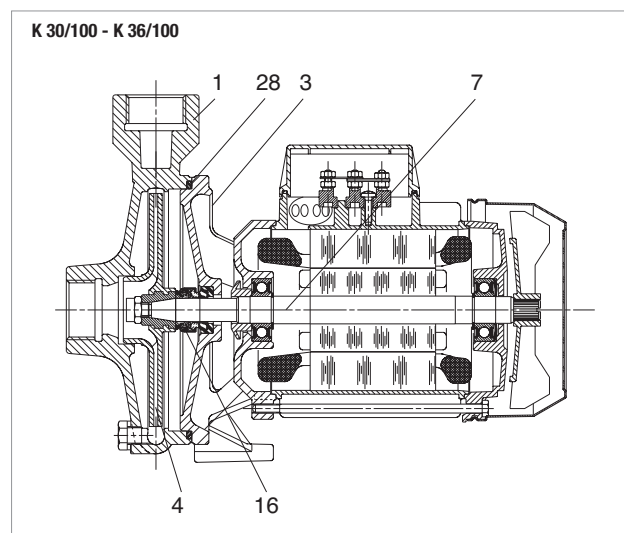
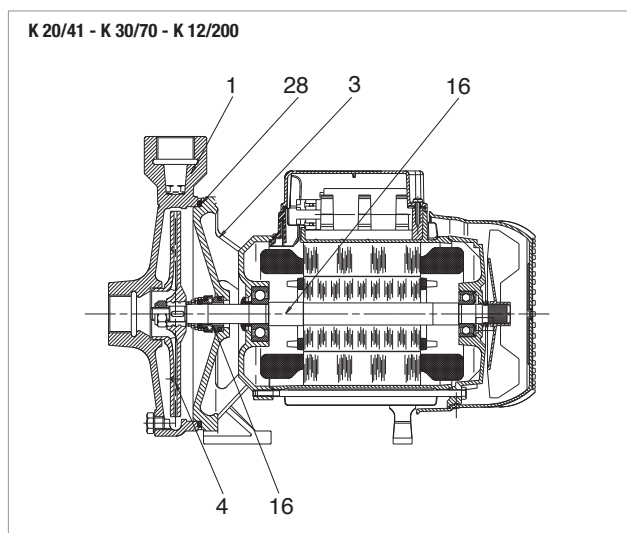

DAB PUMPS reserves the right to make modifications without notice.



K SINGLE-IMPELLER RANGE

ELECTRIC PUMPS

PERFORMANCE RANGE

The performance curves are based on kinematic viscosity values = 1 mm²/s and density equal to 1000 kg/m³. Curve tolerance according to ISO 9906.

GRAPHIC SELECTION TABLE

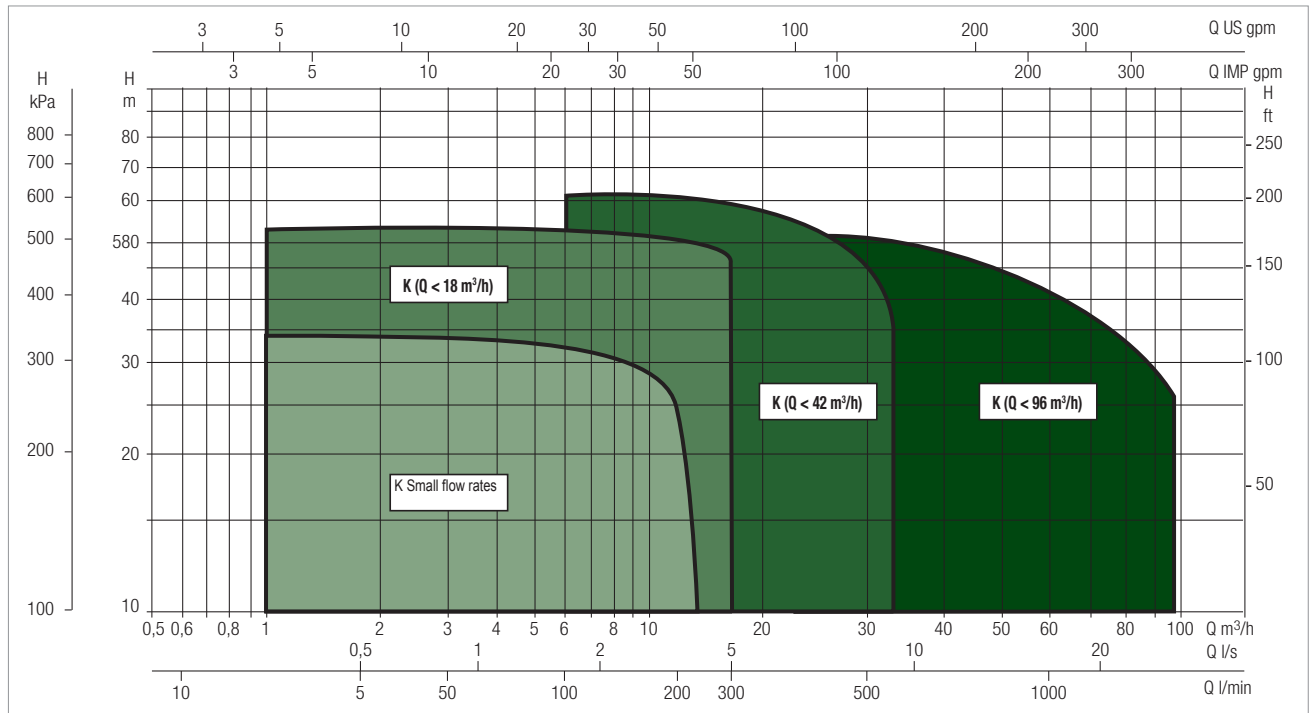

SELECTION TABLE

MODEL	Q=	0	1.8	2.4	3.6	4.8	6	7.2	9	9.6	10.8	12	15	18	24	30	36	42	60	72	84	96	
	m ³ /h	0	30	40	60	80	100	120	150	160	180	200	250	300	400	500	600	700	1000	1200	1400	1600	
K 20/41 M-T	H (m)	22	20.3	19.4	16.9	13.6	8.3																
K 30/70 M-T		31.8	29.5	28.9	27	24.2	19.8	13.5															
K 30/100 M-T		29.2		29	28.8	28	26.8	25.3	22.5	21.5	18.5												
K 36/100 M-T		34.9		34.8	34.6	34	33	32	29.8	29	26.5												
K 12/200 M-T		18.7	18.2	18	17.9	17.7	17.4	17	16.1	15.8	14.9	14	11.2	7.7									
K 36/200 T		36.6				36	35.5	35	34	33.3	32.5	31.5	28	23.5									
K 40/200 T		41.3				41	40.5	40	39	38.8	38	37	33.5	29									
K 55/200 T		54				54	53.9	53.2	53	52	51.5	48.5	45										
K 14/400 M-T		19									18.8	18.5	18	16.3	13.8	10							
K 11/500 T		25.1									26	25.6	25.2	22.9	18.7	13.7	7.7						
K 18/500 T		30.9									32	31.8	30	28.5	25	19.3	13.1						
K 28/500 T		35.4									36.6	36.1	35.6	33.2	30.1	24.7	18.1						
K 40/400 T		50.5									49	48	45	37	24								
K 50/400 T		62									61	60	59	54.5	46								
K 30/800 T		44												42	40	38	35	21.5					
K 40/800 T		51.5												50	48	47	43.5	32.5	21				
K 50/800 T		58												56.5	55	53.5	51	41	31				
K 20/1200 T		37.5												36.5	36	35	34	30	26	21	15		
K 25/1200 T		40.7												39	38.5	38	37	33.5	30	25	18		
K 35/1200 T		45													43	42.5	38.5	35	31.5	27			

K 40/200 - SINGLE-IMPELLER CENTRIFUGAL ELECTRIC PUMPS FOR WATER SUPPLY IN DOMESTIC, CIVIL, AND INDUSTRIAL ENVIRONMENTS

Pumped liquid temperature range: from -10 °C to +50°C - Maximum ambient temperature: +40°C

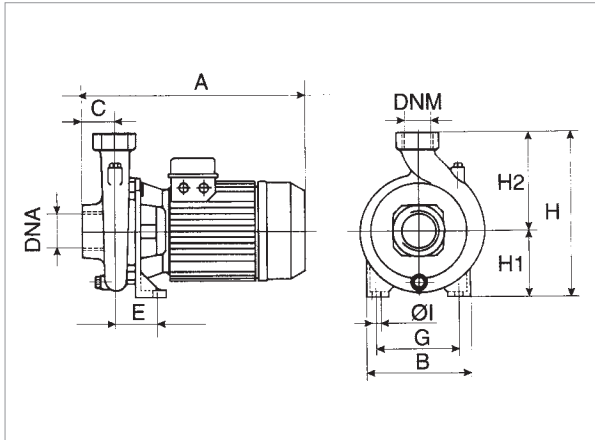

See hydraulic efficiency details on page 291.

The performance curves are based on kinematic viscosity values = 1 mm²/s and density equal to 1000 kg/m³. Curve tolerance according to ISO 9906.

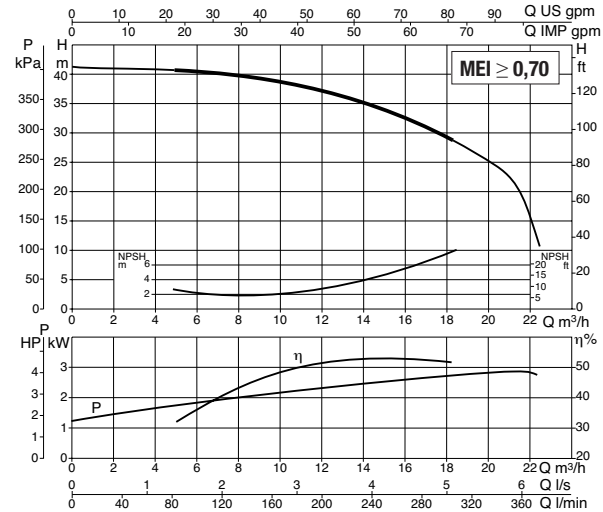

MODEL	ELECTRICAL DATA							
	POWER INPUT 50 Hz	P1 MAX kW	P2 NOMINAL		In A	MOTOR TYPE	I st. A	rpm n. 1/min.
			kW	HP				
K 40/200 T	3x230-400 V ~	3.5	3	4	11.1-6.4	IE2	67.5-39	2830

MODEL	A	B	C	E	G	ØI	H	H1	H2	DNA	DNM	PACKING DIMENSIONS			VOLUME (m ³)	WEIGHT kg
												L/A	L/B	H		
K 40/200	425	250	55	86	175	14	320	135	185	2" G	1 1/4" G	512	276	345	0.049	34.9