

Generator set data sheet

**Model:** C170 D5  
**Frequency:** 50  
**Fuel type:** Diesel

<b>Spec sheet:</b>	<b>SS28-CPGK</b>
<b>Noise data sheet (open/enclosed):</b>	<b>ND50-CS550</b>
<b>Airflow data sheet:</b>	<b>AF50-550</b>
<b>Derate data sheet (open/enclosed):</b>	<b>TBD</b>
<b>Transient data sheet:</b>	<b>TD50-550</b>

<b>Fuel consumption</b>	<b>Standby</b>				<b>Prime</b>			
	<b>kVA (kW)</b>				<b>kVA (kW)</b>			
<b>Ratings</b>	170 (136)				155 (124)			
<b>Load</b>	<b>1/4</b>	<b>1/2</b>	<b>3/4</b>	<b>Full</b>	<b>1/4</b>	<b>1/2</b>	<b>3/4</b>	<b>Full</b>
<b>gph</b>	4.0	6.1	8.3	10.5	3.2	5.3	8.1	9.5
<b>L/hr</b>	15.20	23.20	31.50	39.60	12.10	20.00	30.60	36.00

<b>Engine</b>	<b>Standby rating</b>	<b>Prime rating</b>
Engine manufacturer	TCL	
Engine model	6BTA5.9-G7	
Configuration	4-cycle, In-line, 6-cylinder,	
Aspiration	Turbocharged and charged air cooled	
Gross engine power output, kWm	160	145
BMEP at set rated load, kPa	2178	1972
Bore, mm	102	
Stroke, mm	120	
Rated speed, rpm	1500	
Piston speed, m/s	6	
Compression ratio	16.5 :1	
Lube oil capacity, L	16.4	
Overspeed limit, rpm	1800	
Regenerative power, kW	NA	
Governor type	Electronic	
Starting voltage	12V	

<b>Fuel flow</b>	
Maximum fuel flow, L/hr	45
Maximum fuel inlet restriction, mm Hg	101 / 203 (clean / dirty filter)
Maximum fuel inlet temperature, °C	71

<b>Air</b>	<b>Standby rating</b>	<b>Prime rating</b>
Combustion air, m <sup>3</sup> /min	12.43	11.81
Maximum air cleaner restriction, kPa	4	

### Exhaust

Exhaust gas flow at set rated load, m <sup>3</sup> /min	32.37	31.12
Exhaust gas temperature, °C	533	517
Maximum exhaust back pressure, kPa	10.25	

### Standard set-mounted radiator cooling

Ambient design, °C	50	
Fan load, kW <sub>m</sub>	9.8	
Coolant capacity (with radiator), L	22.1	
Cooling system air flow, m <sup>3</sup> /sec @ 12.7 mmH <sub>2</sub> O	3.77	
Total heat rejection, Btu/min	3128	2900
Maximum cooling air flow static restriction mm H <sub>2</sub> O	12.7	

### Weights\*

	<b>Open</b>	<b>Enclosed</b>
Unit dry weight kgs	1635	2390
Unit wet weight kgs	1650	2400

\* Weights represent a set with standard features. See outline drawing for weights of other configurations.

### Dimensions

	<b>Length</b>	<b>Width</b>	<b>Height</b>
Standard open set dimensions	2537	1090	1846
Standard enclosed set dimensions	3460	1090	2387

### Genset outline

#### Open set

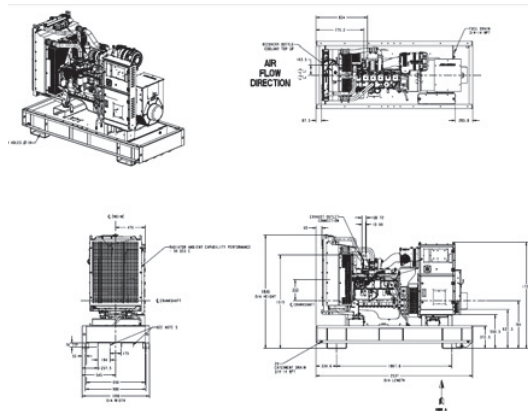

#### Enclosed set

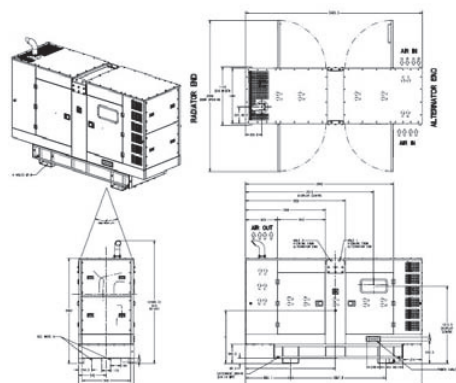

## Alternator data

Connection <sup>1</sup>	Temp rise °C	Duty <sup>2</sup>	Alternator	Voltage
WYE	163	ESP	UCI274F	190-208 & 380 - 416 V
WYE	150	ESP	UCI274G	190-208 & 380 - 416 V
WYE	125	PRP	UCI274F	190-208 & 380 - 416 V
WYE	105	PRP	UCI274G	190-208 & 380 - 416 V

## Ratings definitions

Emergency standby power (ESP):	Limited-time running power (LTP):	Prime power (PRP):	Base load (continuous) power (COP):
Applicable for supplying power to varying electrical load for the duration of power interruption of a reliable utility source. Emergency Standby Power (ESP) is in accordance with ISO 8528. Fuel Stop power in accordance with ISO 3046, AS 2789, DIN 6271 and BS 5514.	Applicable for supplying power to a constant electrical load for limited hours. Limited Time Running Power (LTP) is in accordance with ISO 8528.	Applicable for supplying power to varying electrical load for unlimited hours. Prime Power (PRP) is in accordance with ISO 8528. Ten percent overload capability is available in accordance with ISO 3046, AS 2789, DIN 6271 and BS 5514.	Applicable for supplying power continuously to a constant electrical load for unlimited hours. Continuous Power (COP) is in accordance with ISO 8528, ISO 3046, AS 2789, DIN 6271 and BS 5514.

## Formulas for calculating full load currents:

### Three phase output

$$\frac{\text{kW} \times 1000}{\text{Voltage} \times 1.73 \times 0.8}$$

### Single phase output

$$\frac{\text{kW} \times \text{SinglePhaseFactor} \times 1000}{\text{Voltage}}$$