



## Table of Contents

Performance Assurance	<b>3</b>
Features and Benefits	<b>4-5</b>
Specifications	<b>6</b>
Shaft Torque Ratings	<b>7</b>
Pump Controls	<b>8</b>
Pressure Compensator	<b>8</b>
Dual Pressure Compensator	<b>8</b>
Soft Start Pressure Compensator	<b>9</b>
Load Sensing	<b>9</b>
Load Sense Plus	<b>10</b>
Horsepower Limiter	<b>10</b>
Horsepower Limiter w/Load Sensing	<b>11</b>
Horsepower Limiter w/Load Sense Plus	<b>11</b>
Dual Pressure Compensator w/HP Limiter	<b>12</b>
Soft Start Pressure Compensator w/HP Limiter	<b>12</b>
Electronic Displacement Control (EDC)	<b>13</b>
Electronic Displacement Control (EDC) w/Load Sensing	<b>13</b>
Electronic Proportional Pressure Compensator	<b>14</b>
Electronic Servo Valve	<b>14</b>
Fixed Volume	<b>14</b>
Performance Data	<b>15-17</b>
Sound Data	<b>18-20</b>
Inlet Data	<b>21-23</b>
How to Order	<b>24-26</b>
Supporting Documents	<b>27</b>

# PERFORMANCE ASSURANCE – STANDARD WITH EVERY OILGEAR COMPONENT



**Oilgear**  
PERFORMANCE  
ASSURANCE

**Every** Oilgear product is shipped to you with our Performance Assurance — a corporate commitment to stay with your installation until our equipment performs as specified.

Hydraulic equipment and systems have been Oilgear's primary business since 1921. For decades, we have developed hydraulic techniques to meet the unique needs and unusual fluid power problems of machinery builders and users worldwide, matching fluid power systems to a tremendous range of applications and industries. Our exclusive Performance Assurance program is built upon that strong foundation.

As a customer, you also benefit from access to Oilgear's impressive technical support network.

You'll find factory trained and field-experienced application engineers on staff at every Oilgear facility. They are backed by headquarters staff who can access the records and knowledge learned from decades of solving the most difficult hydraulic challenges.

When your design or purchase is complete, our service is just beginning. If you ever need us, our Oilgear engineers will be there, ready to help you with the education, field service, parts and repairs to assure that your installation runs smoothly—and keeps right on running.

**Oilgear** Performance Assurance

## PVG Open Loop Pumps

Computer optimized, high pressure high volume pump, with Oilgear's time proven rotating group.

Large control selection.

- Pressure and volume controls are available with a large variety of options.
- Field interchangeability without disconnecting from drive or system piping.

Four-way pilot operated control.

- Provides fast on and off stroke time.
- Maintains constant pressure over full volume range.
- Delivers high performance in a compact package.

SAE Heavy duty shaft.

- Allows high thru torque capability.
- Dual units can handle full pressure and volume.
- SAE keyed or SAE splined shaft.

Sealed front shaft bearings.

- Enables operation with low viscosity or other special fluids.

Patented pressure lubricated swashblock.

- Delivers high performance for high pressure high cycle operation.
- Pressure lubricated upper and lower saddle bearings provide for long life.

Hardened steel shoes with specially designed face for increased fluid retention, running on hardened swashblock surface.

- Provides a higher degree of contaminate resistance.
- Allows higher pressure operation.
- Enables operation with low viscosity or other special fluids.
- Provides long life at rated pressure.

Swashblock with polymerous bearings.

- Allows running on low viscosity or other special fluids.
- Permits constant control reaction with low hysteresis.
- Eliminates troublesome yoke bearings
- Provides long life.

Rugged cylinder design.

- Hardened nodular iron construction for improved performance and contamination resistance.

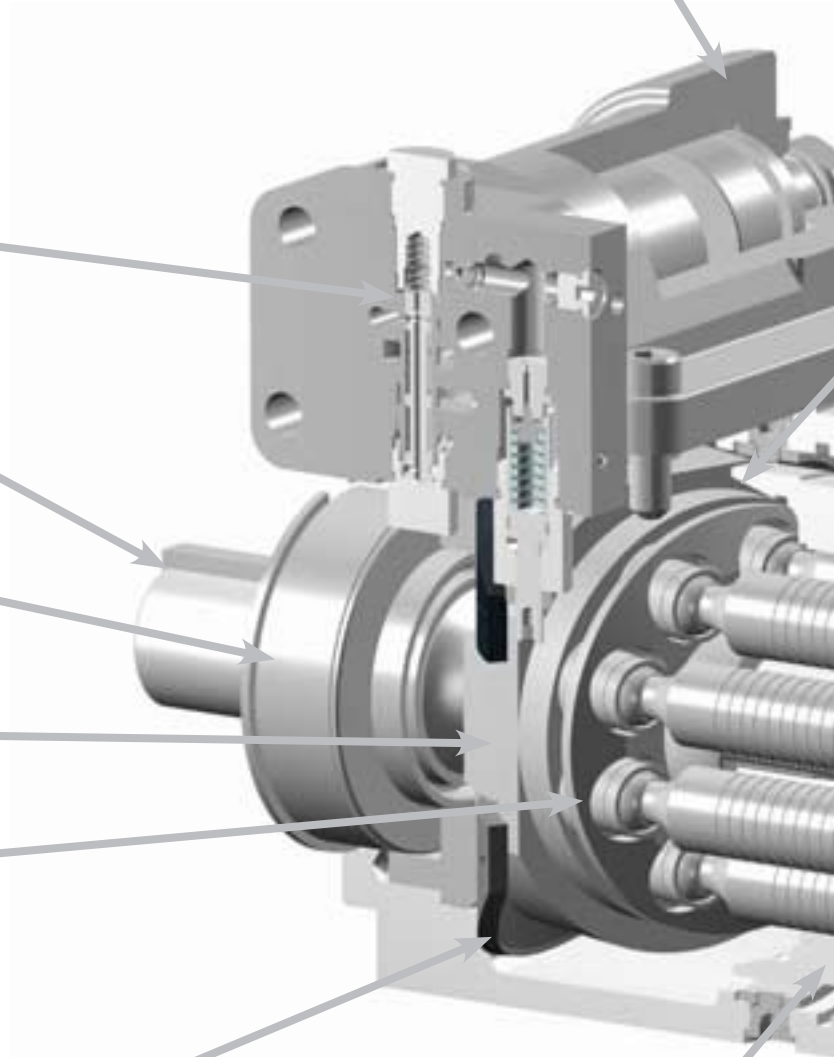

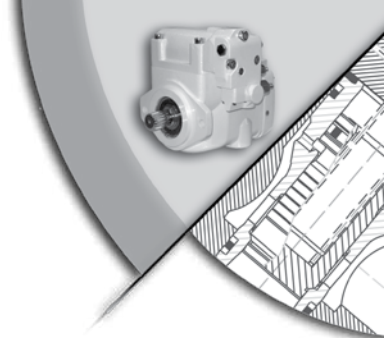

Cylinder mounted polymerous journal bearings.

- Allows operation with low viscosity or other special fluids.
- Provides infinite bearing life.
- Enables compact design.

Hardened cylinder surface running on hardened valve plate "hard-on-hard".

- Provides greater resistance to contamination.
- Provides long life.
- Allows operation with low viscosity or other special fluids.

Valve plate selection.

- Top and bottom port connections available.
- Allows for multiple pump installation from a single drive shaft.
- Dual configuration with capability of full load on both pumps.
- Has provisions for mounting "AA" thru "D" sizes for rear pumps.
- Both 2 and 4 bolt SAE mounts available.

Quiet valve plate design.

- Minimizes noise at typical electric motor speeds.
- Hardened nodular iron construction for long life.

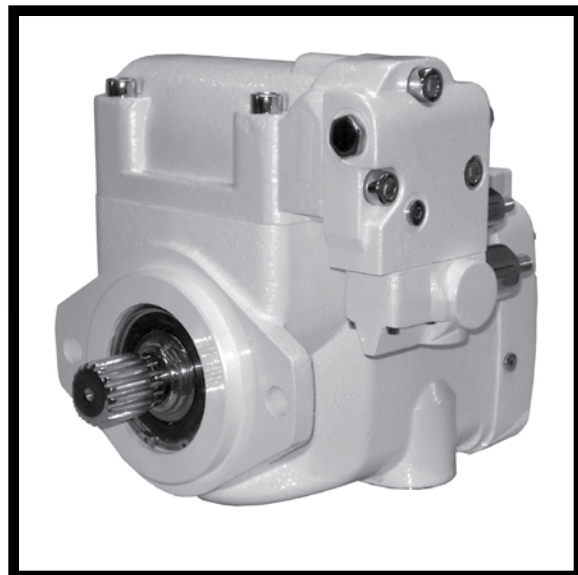

# Oilgear Features and Benefits

## Nominal Performance Specifications

UNIT SIZE	THEORETICAL MAXIMUM DISPLACEMENT		RATED CONTINUOUS PRESSURE		PEAK PRESSURE		FLOW RATE at 1800 rpm, rated cont. pressure & 14.7 psia (bar abs) inlet conditions		MAXIMUM SPEED rpm	POWER INPUT at rated cont. pressure & 1800 rpm	
	in <sup>3</sup> /rev.	ml/rev.	psi	bar	psi	bar	gpm	l/min		hp	kw
048	2.93	48,0	5000	344,8	5800	400,0	21.1	79,9	2700	73	54,5
065	3.98	65,0	5000	344,8	5800	400,0	28.8	108,9	2700	100	74,6
075	4.60	75,4	3750	258,6	4250	293,1	33.3	126,0	2700	89	66,4
100	6.00	98,3	5000	344,8	5800	400,0	42.4	160,5	2400	150	111,9
130	7.94	130,2	3750	258,6	4250	293,1	57.6	218,0	2400	150	111,9
150	9.16	150,0	5000	344,8	5800	400,0	63.0	238,5	2400	215	160,4

## Nominal Dimensions

UNIT SIZE	LENGTH		WIDTH		HEIGHT		WEIGHT*		FACE MOUNTING
	in.	mm.	in.	mm.	in.	mm.	lbs.	kg.	
048, 065 & 075	12.0	303,9	6.9	174,5	6.3	160,4	68	31	SAE "B" 2 & 4 Bolt
100 & 130	13.0	330,5	8.4	212,9	7.3	185,7	115	52	SAE "C" 2 Bolt
150	14.2	360,7	7.9	200,7	8.1	205,7	171	78	SAE "D" 4 Bolt

All dimensions (without controls) are approximate. For detailed dimensions, contact your Oilgear Representative.

\* Weights are with P-1 control. 048, 065, 075, 100 & 130 models are with rear ported valve plate.

150 model is with side ported valve plate.



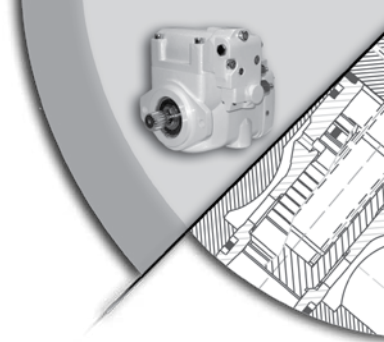

**PVG 048/065/075**

3500 IN-LB = MAXIMUM ALLOWABLE TORQUE APPLIED TO REAR OUTPUT

MODEL CODE DESIGNATOR	SHAFT SIZE	ALLOWABLE INPUT TORQUE IN-LB
"Y"	1.00" KEY LONG	3,500
"S"	SPLINE 15 TOOTH 16/32 DP	7,000
"K"	SPLINE 13 TOOTH 16/32 DP	3,500
"R"	SPLINE 14 TOOTH 12/24 DP	7,000
"B"	1.25" KEY LONG	6,400

**PVG 100/130**

5250 IN-LB = MAXIMUM ALLOWABLE TORQUE APPLIED TO REAR OUTPUT

MODEL CODE DESIGNATOR	SHAFT SIZE	ALLOWABLE INPUT TORQUE IN-LB
"Y"	1.50" KEY LONG	10,500
"Z"	1.50" KEY SHORT	6,000
"S"	SPLINE 17 TOOTH 12/24 DP	10,500
"K"	SPLINE 14 TOOTH 12/24 DP	7,000
"R"	SPLINE 13 TOOTH 8/16 DP	10,500

**PVG 150**

7500 IN-LB = MAXIMUM ALLOWABLE TORQUE APPLIED TO REAR OUTPUT

MODEL CODE DESIGNATOR	SHAFT SIZE	ALLOWABLE INPUT TORQUE IN-LB
"Y"	1.75" KEYED	15,000
"L"	SPLINE 13 TOOTH 8/16 DP	15,000

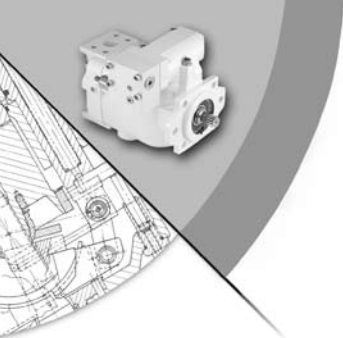

### Pressure Compensator "P-1"

Ensures maximum pump flow until unit reaches preset control pressure setting then regulates output flow to match the requirements of the system while maintaining preset output pressure.

Can be adjusted from 200 psi (250 psi for PVG150) working pressure up to the maximum pressure rating of pump.

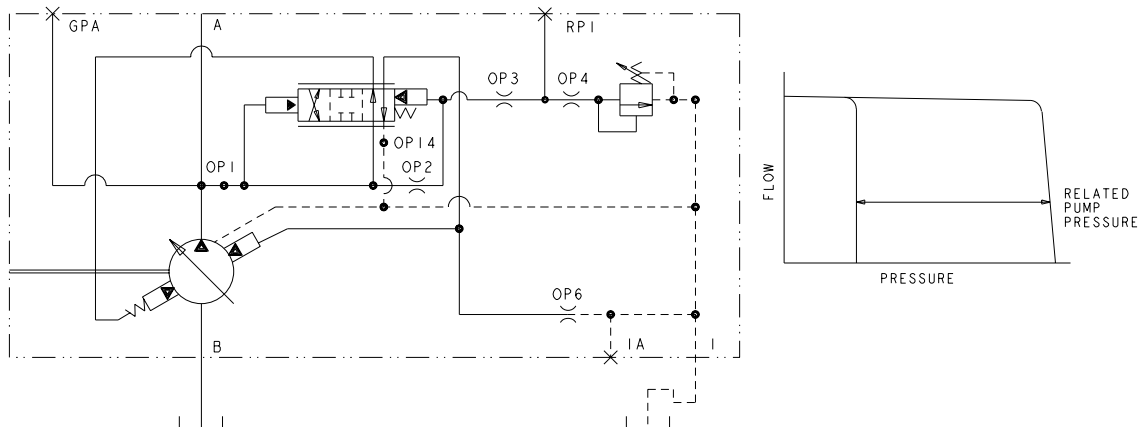

### Dual Pressure Compensator "P-2"

Provides two independently adjustable pressure compensated settings as selected by an integral solenoid.

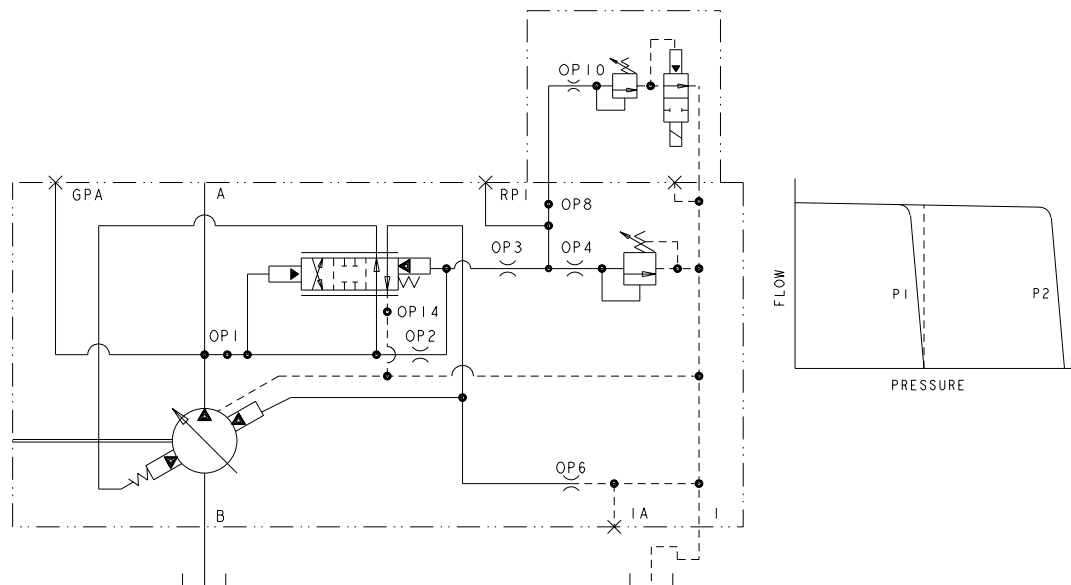



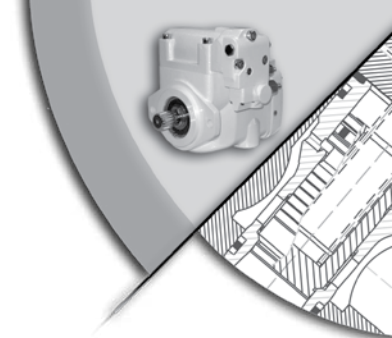

**Soft Start Pressure Compensator "P-C"**

Pump starts "softly" by going quickly at low pressure to a reduced flow setting, thereby reducing start up torque requirements.

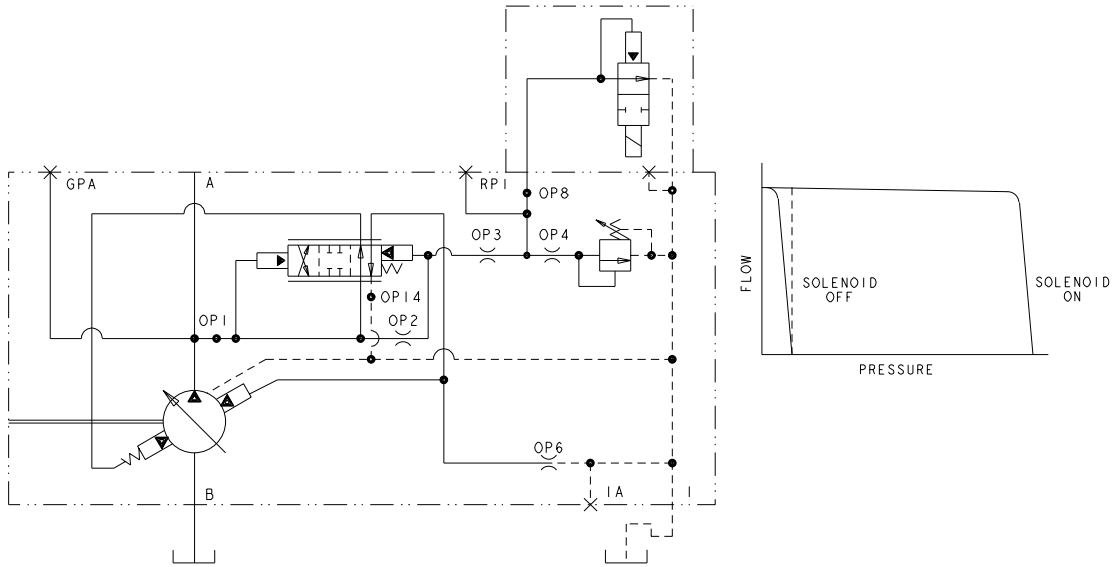

**Load Sensing "P-1/F"**

A constant flow output is maintained for a given flow control valve setting regardless of changes in drive speed and/or working pressure.

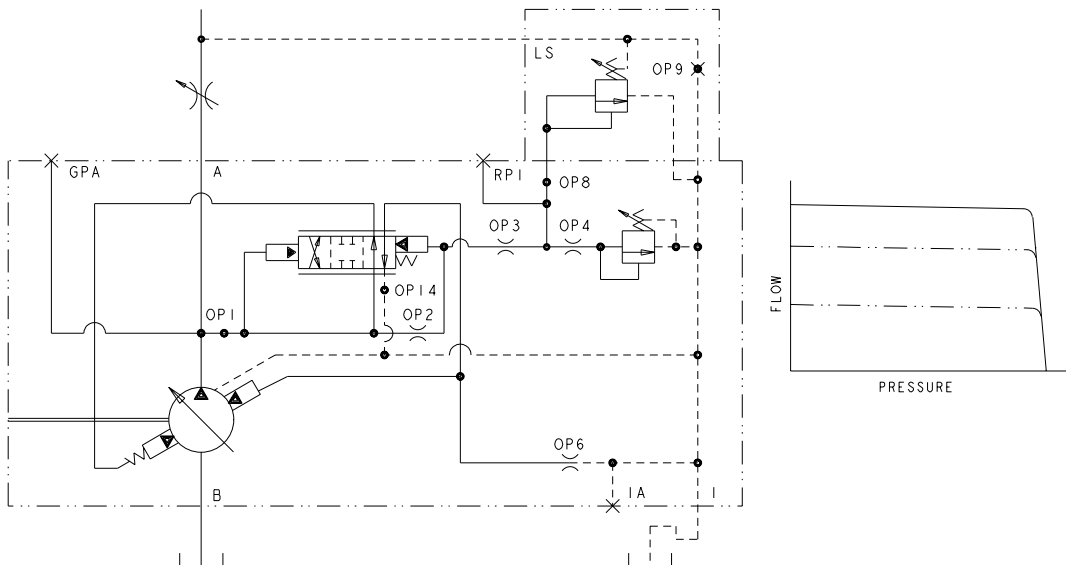

### Load Sense Plus "P-1/K"

A constant flow output is maintained for a given flow control valve setting regardless of changes in drive speed and/or working pressure. The Load Sense Plus control enables the user to externally adjust the minimum pressure setting without affecting the load sense differential.

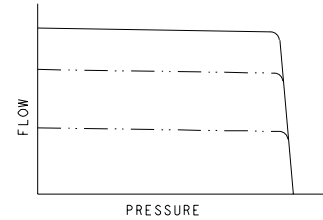
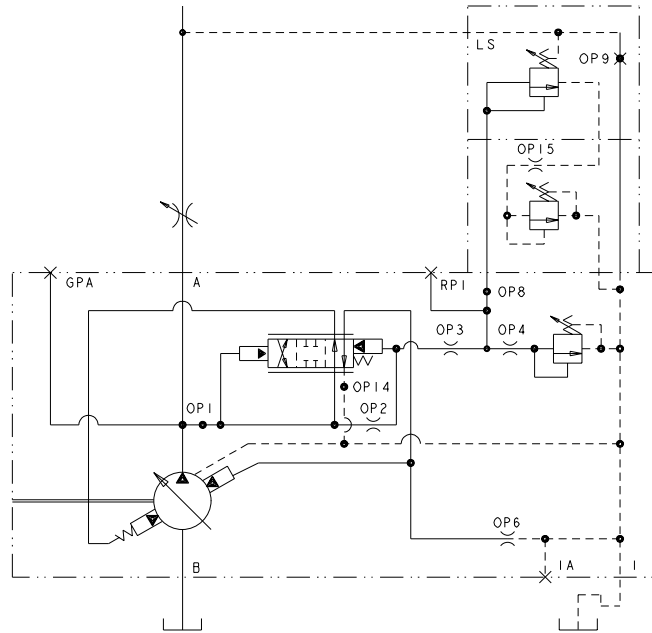

### Horsepower Limiter "P-1/H"

Automatically reduces delivery, as unit pressure rises, to limit horsepower consumption.

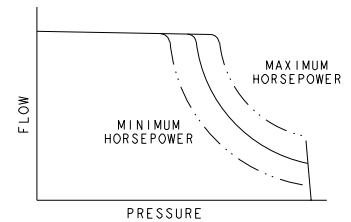
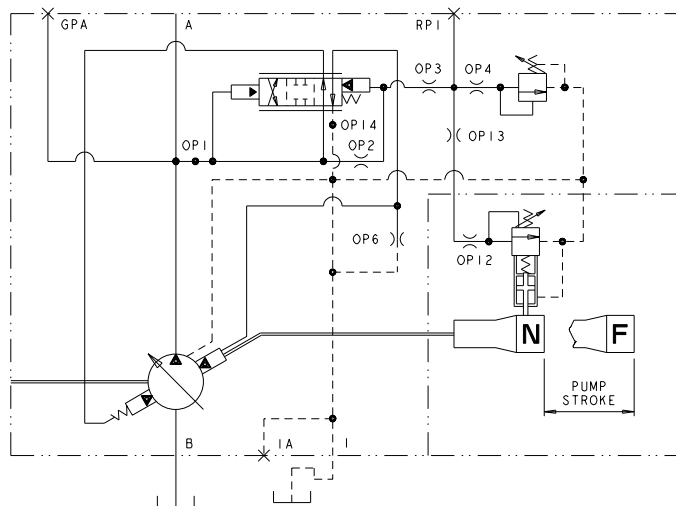

MODEL	MINIMUM HORSEPOWER	MAXIMUM HORSEPOWER	MINIMUM HORSEPOWER TO OBTAIN FLOW AT RATED PRESSURE
-048	20	80	25
-065	20	80	25
-075	20	80	20
-100	18	125	35
-130	18	125	35
-150	50	190	50

ALL HORSEPOWER VALUES ARE FOR 1800 RPM.

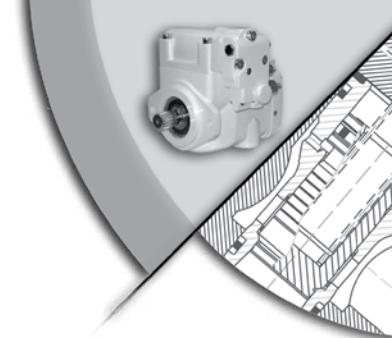

### Horsepower Limiter w/Load Sensing "P-1/G"

Load sensing control matches flow and pressure to load demand until (limited) horsepower setting is reached. Control then automatically reduces delivery as system pressure rises.

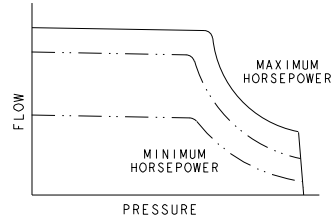
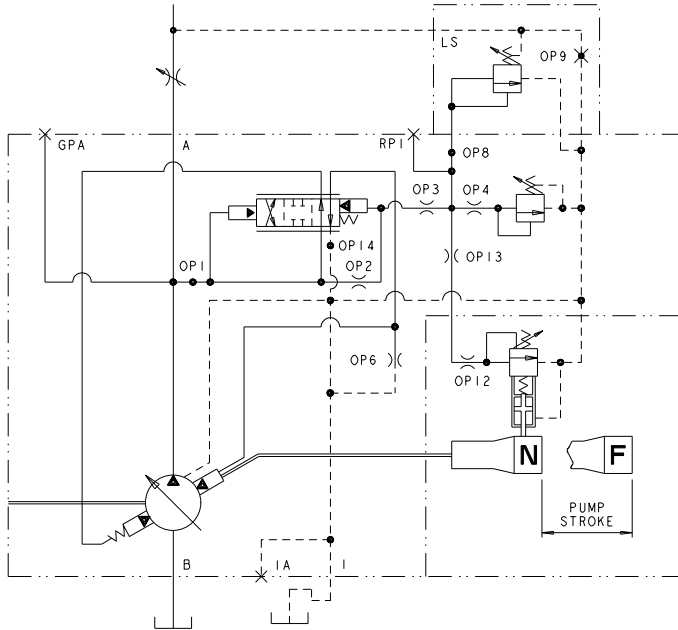

MODEL	MINIMUM HORSEPOWER	MAXIMUM HORSEPOWER	MINIMUM HORSEPOWER TO OBTAIN FLOW AT RATED PRESSURE
-048	20	80	25
-065	20	80	25
-075	20	80	20
-100	18	125	35
-130	18	125	35
-150	50	190	50

ALL HORSEPOWER VALUES ARE FOR 1800 RPM.

### Horsepower Limiter w/Load Sense Plus "P-1/L"

Load sensing control matches flow and pressure to load demand until (limited) horsepower setting is reached. Control then automatically reduces delivery as system pressure rises. The Load Sense Plus control enables the user to externally adjust the minimum pressure setting without affecting the load sense differential.

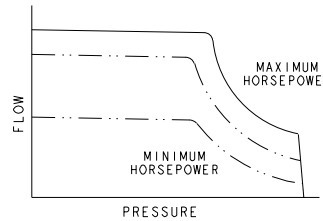
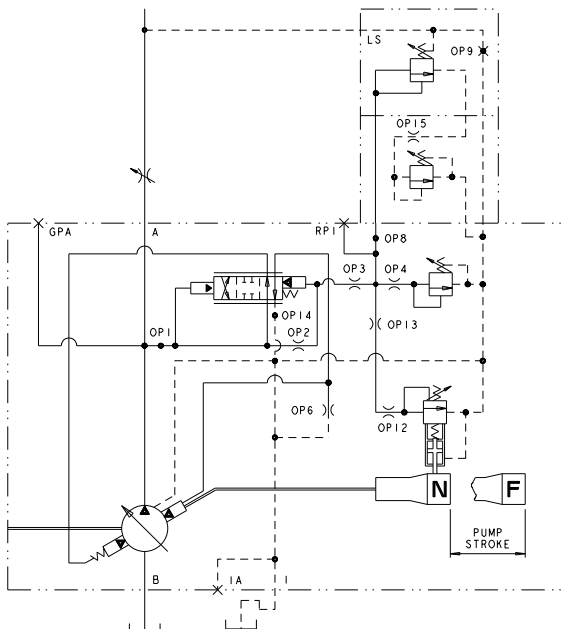

MODEL	MINIMUM HORSEPOWER	MAXIMUM HORSEPOWER	MINIMUM HORSEPOWER TO OBTAIN FLOW AT RATED PRESSURE
-048	20	80	25
-065	20	80	25
-075	20	80	20
-100	18	125	35
-130	18	125	35
-150	50	190	50

ALL HORSEPOWER VALUES ARE FOR 1800 RPM.

### Dual Pressure Compensator w/Horsepower Limiter "P-2/H"

Provides two independently adjustable pressure compensated settings as selected by an integral solenoid. Automatically reduces delivery, as unit pressure rises, to limit horsepower consumption.

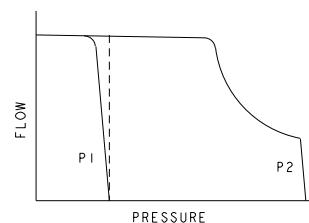
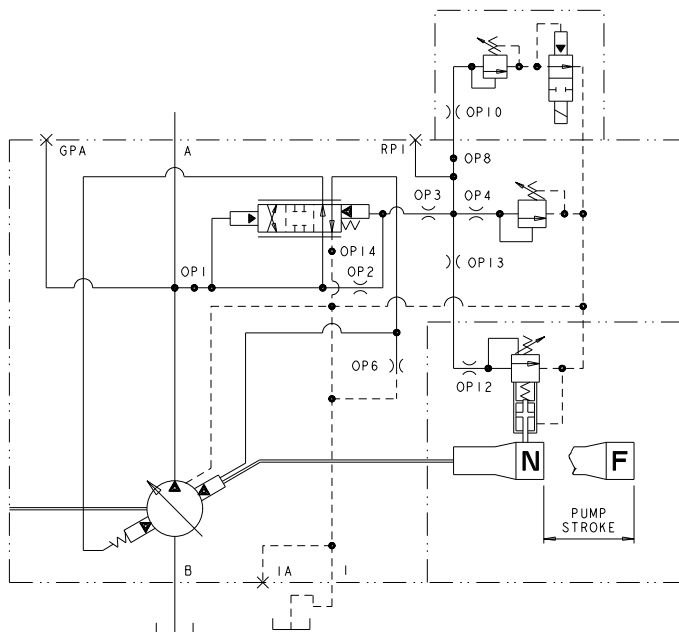

MODEL	MINIMUM HORSEPOWER	MAXIMUM HORSEPOWER	MINIMUM HORSEPOWER TO OBTAIN FLOW AT RATED PRESSURE
-048	20	80	25
-065	20	80	25
-075	20	80	20
-100	18	125	35
-130	18	125	35
-150	50	190	50

ALL HORSEPOWER VALUES ARE FOR 1800 RPM.

### Soft Start Pressure Compensator w/Horsepower Limiter "P-C/H"

Pump starts "softly" by going quickly at low pressure to a reduced flow setting, thereby reducing start up torque requirements. Automatically reduces delivery, as unit pressure rises, to limit horsepower consumption.

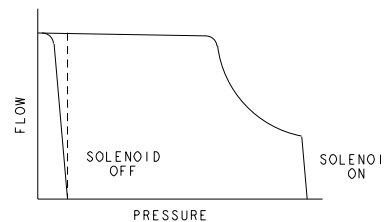
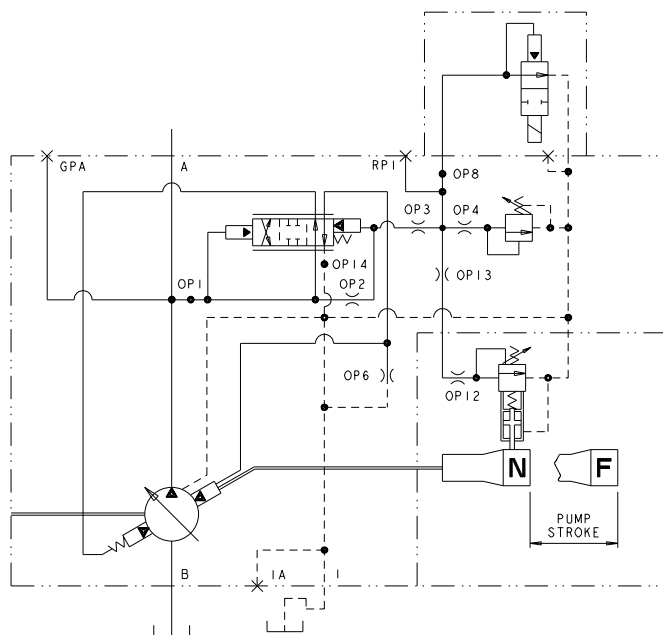

MODEL	MINIMUM HORSEPOWER	MAXIMUM HORSEPOWER	MINIMUM HORSEPOWER TO OBTAIN FLOW AT RATED PRESSURE
-048	20	80	25
-065	20	80	25
-075	20	80	20
-100	18	125	35
-130	18	125	35
-150	50	190	50

ALL HORSEPOWER VALUES ARE FOR 1800 RPM.



**Electronic Proportional Pressure Compensator "P-A" (N.O.) "P-B" (N.C.)**

Provides an infinite number of independent remotely adjustable pressure settings in response to an electrical command. (P-A shown)

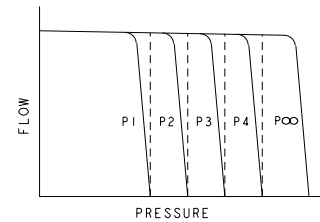
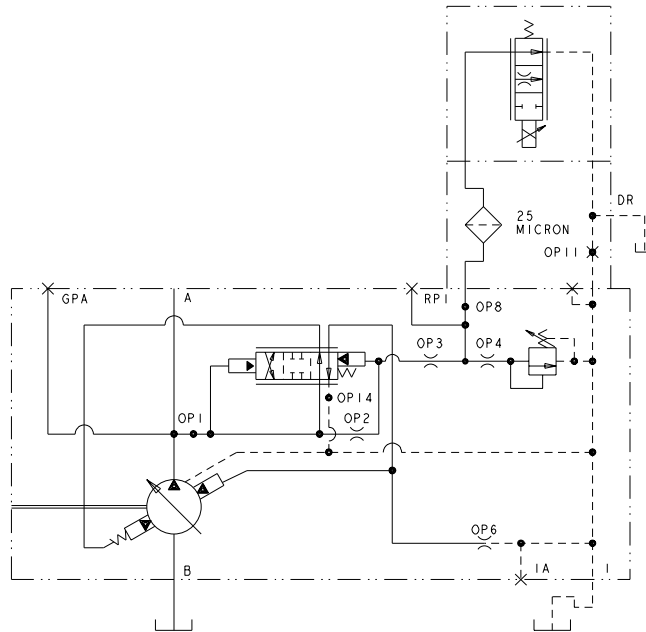

**Electronic Servo Valve "V-M" "V-S"**

An electrohydraulic servo valve positions the swashplate mechanism with a closed-loop position control (with LVDT feedback).

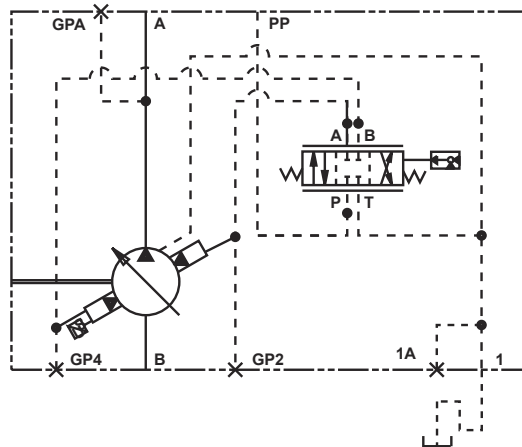

**Fixed Volume "F"**

Fixed displacement units available with stroke setting of three quarters and full volume.

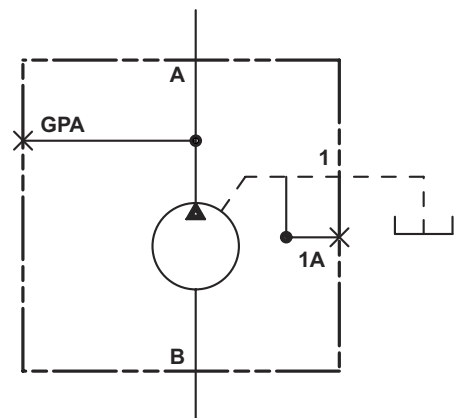



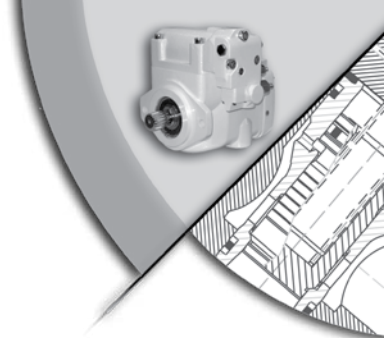

■ PVG-048

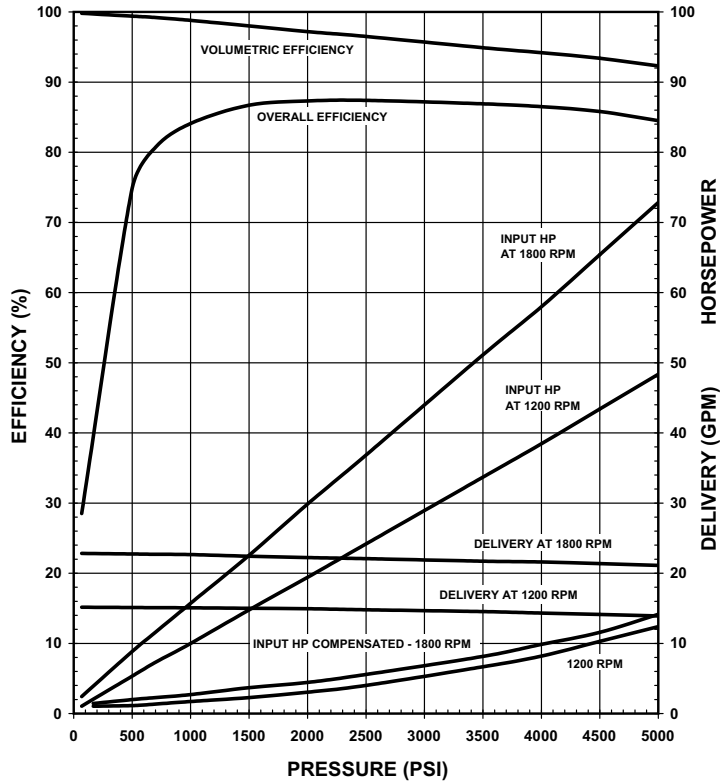

■ PVG-065

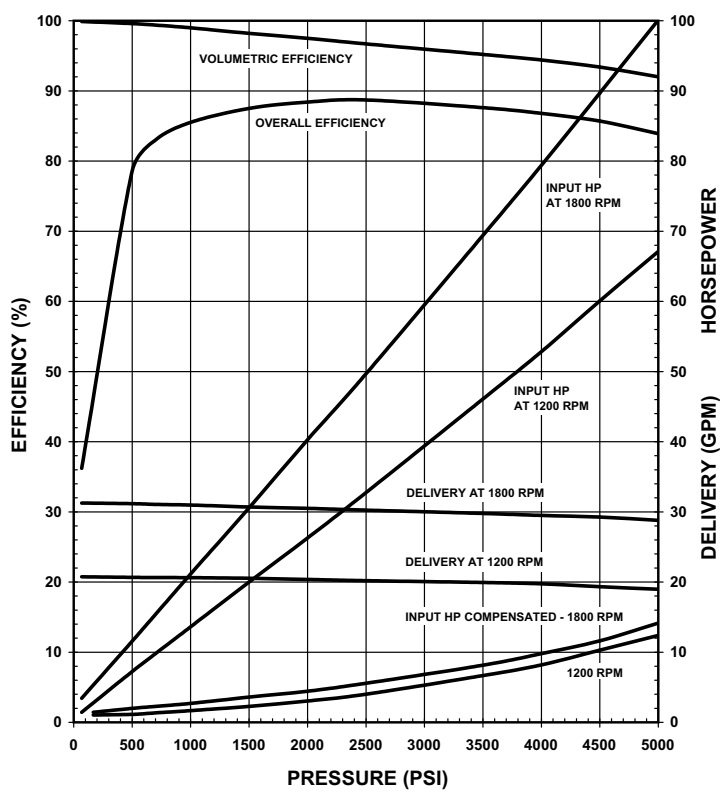

# Oilgear Performance Data

■ PVG-075

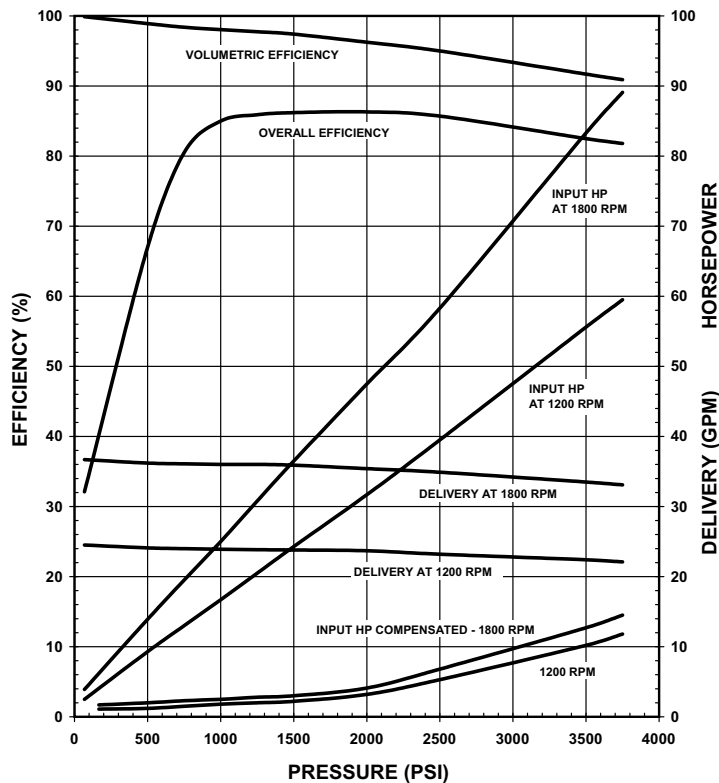

■ PVG-100

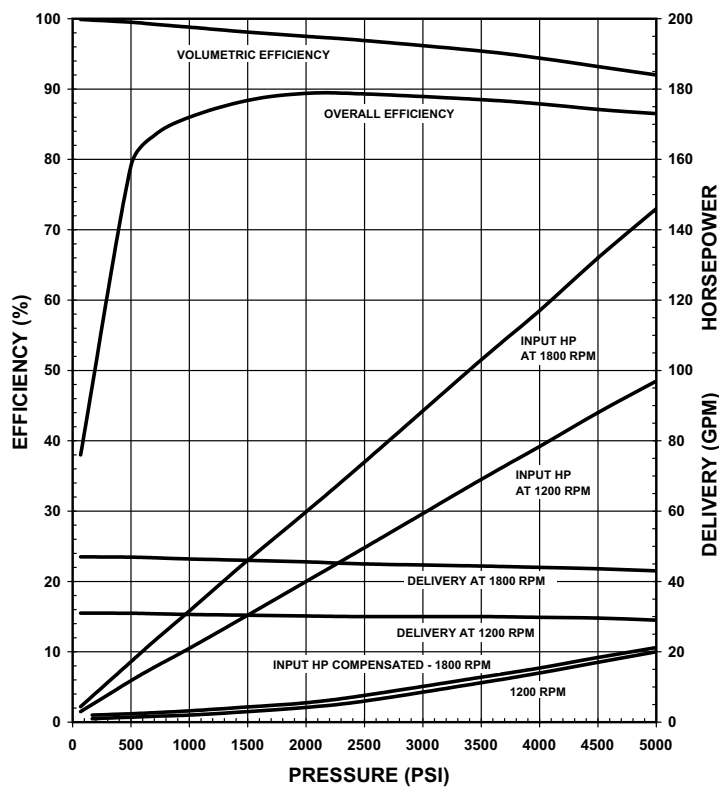

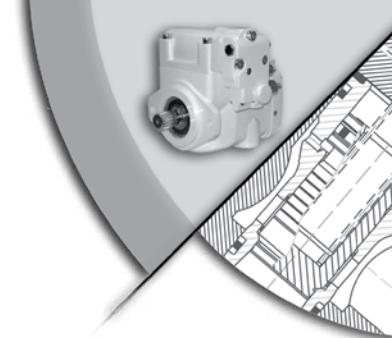

■ PVG-130

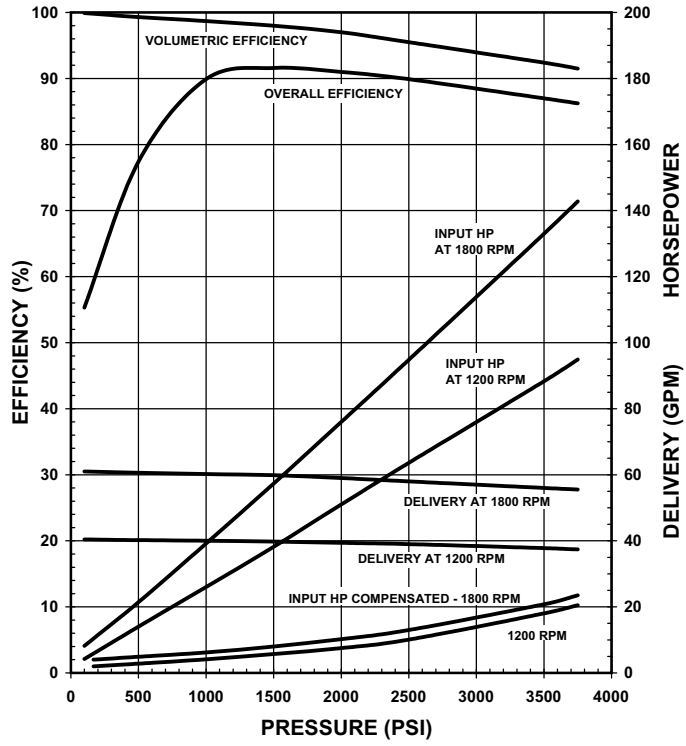

■ PVG-150

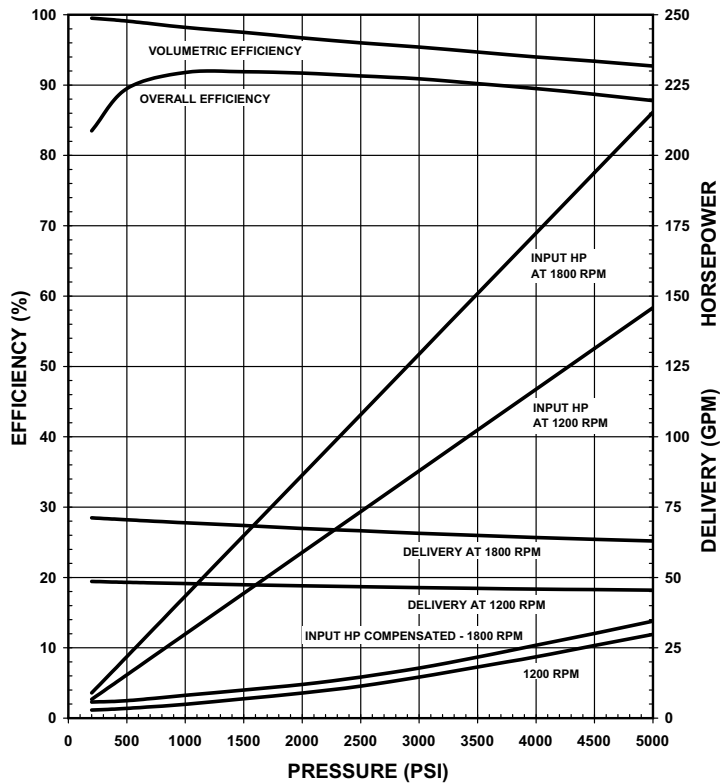

**Oilgear** Performance Data

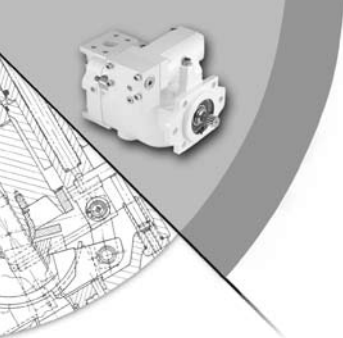

■ PVG-048

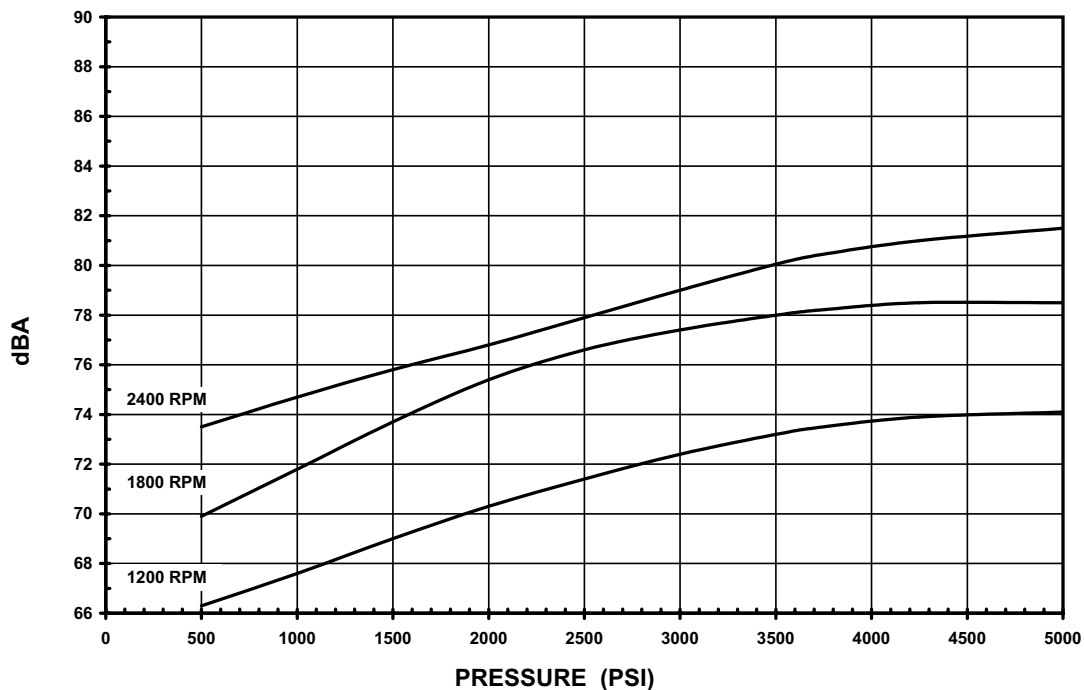

■ PVG-065

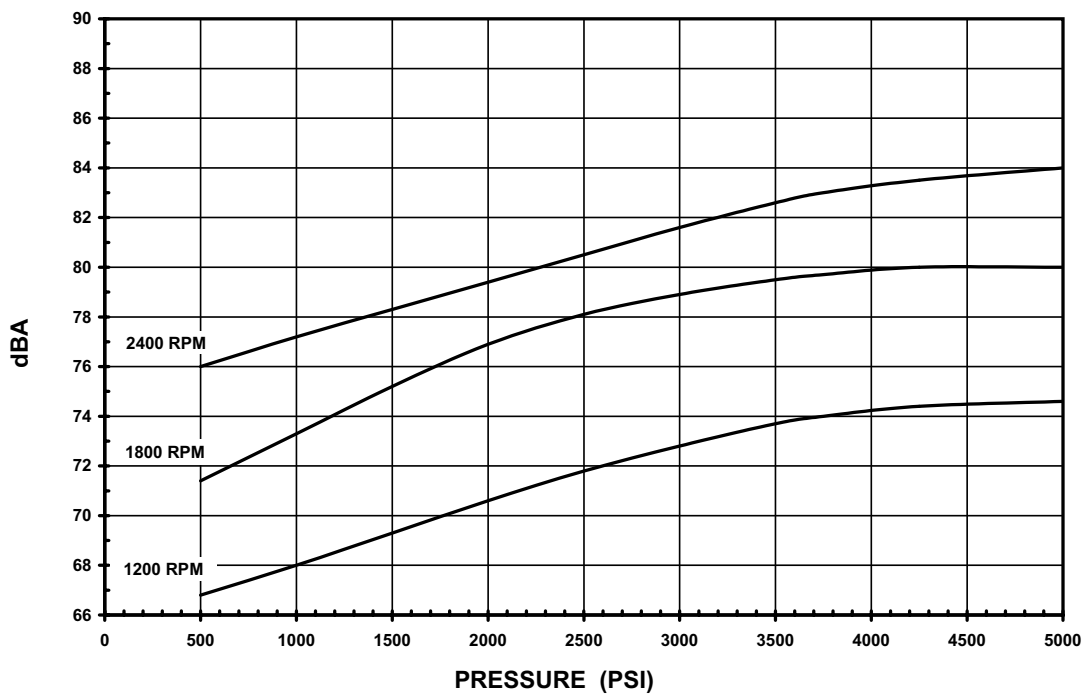

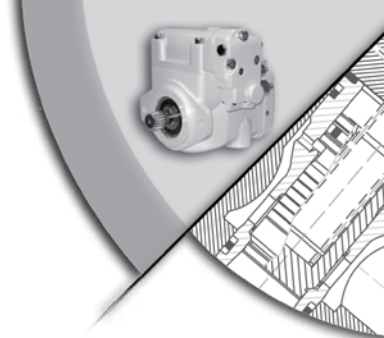

■ PVG-075

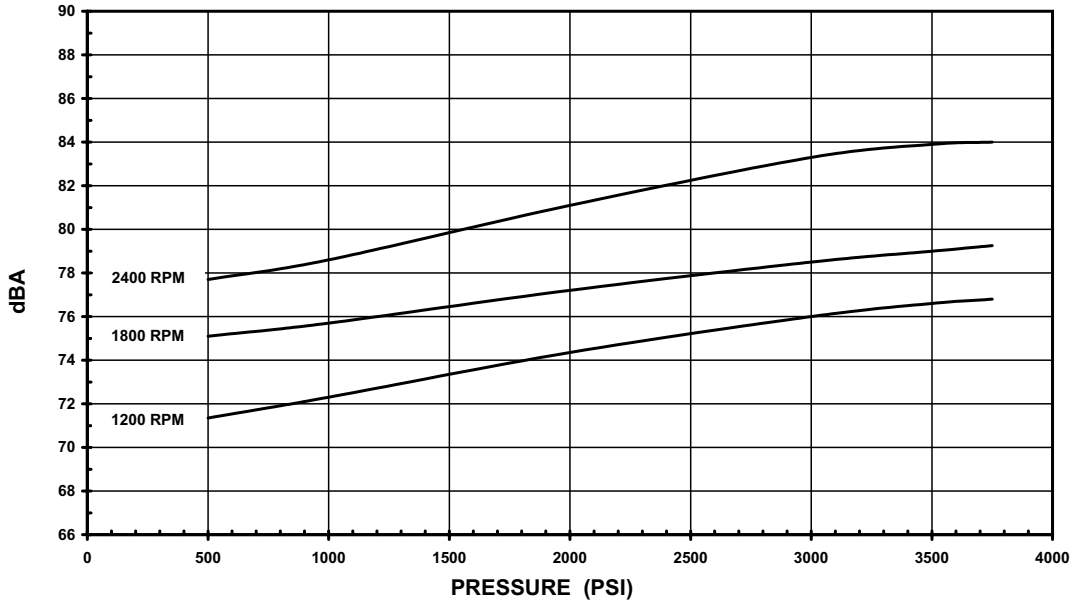

■ PVG-100

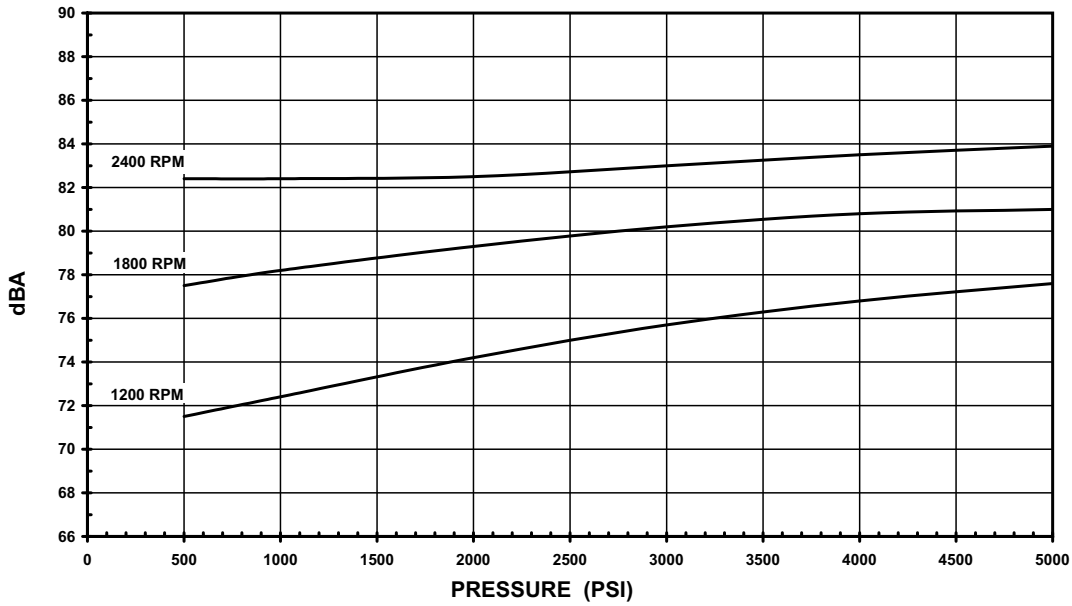

**Oilgear** Sound Data

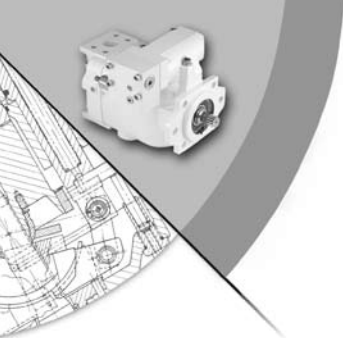

■ PVG-130

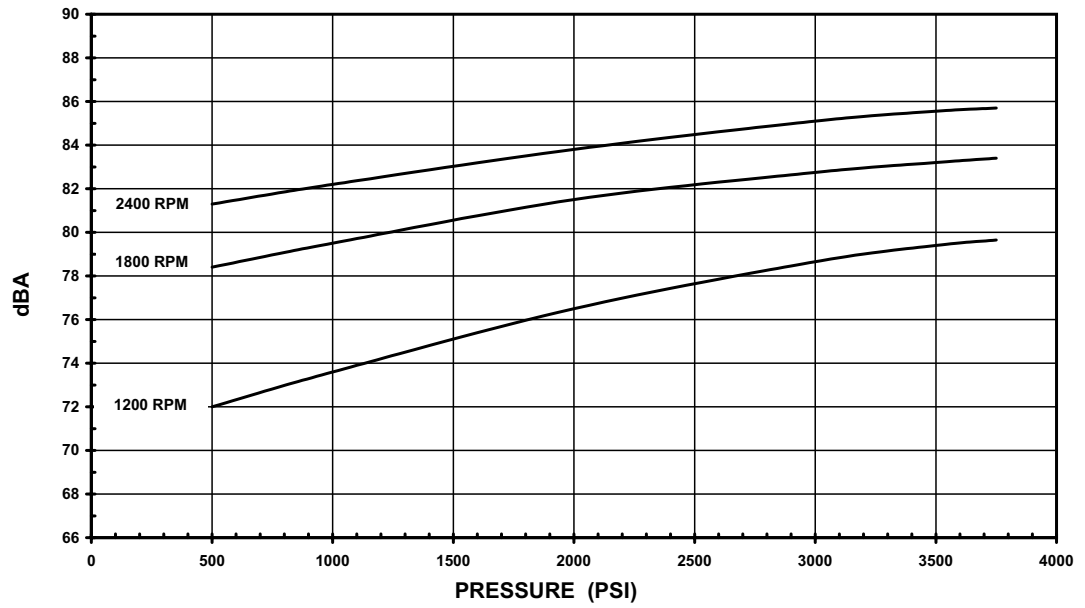

■ PVG-150

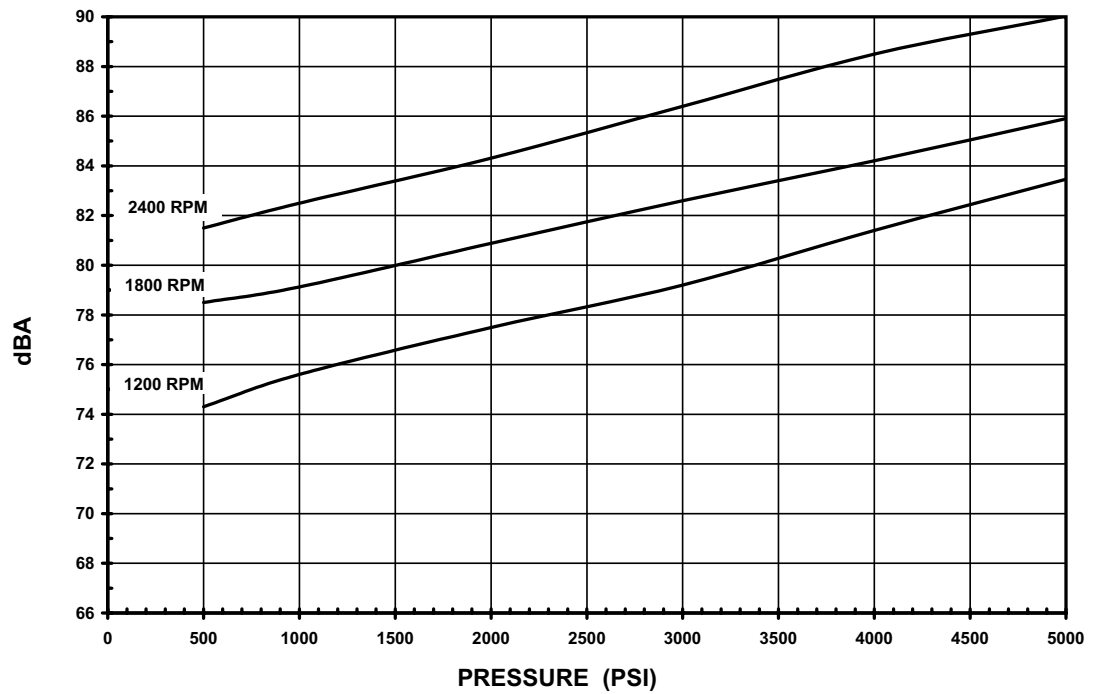



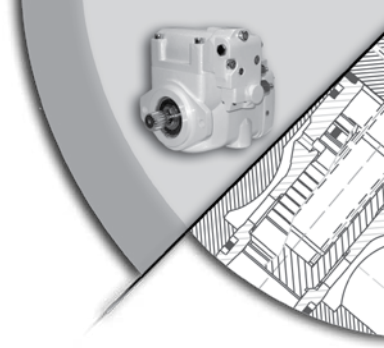

# Oilgear Inlet Data

■ PVG-048

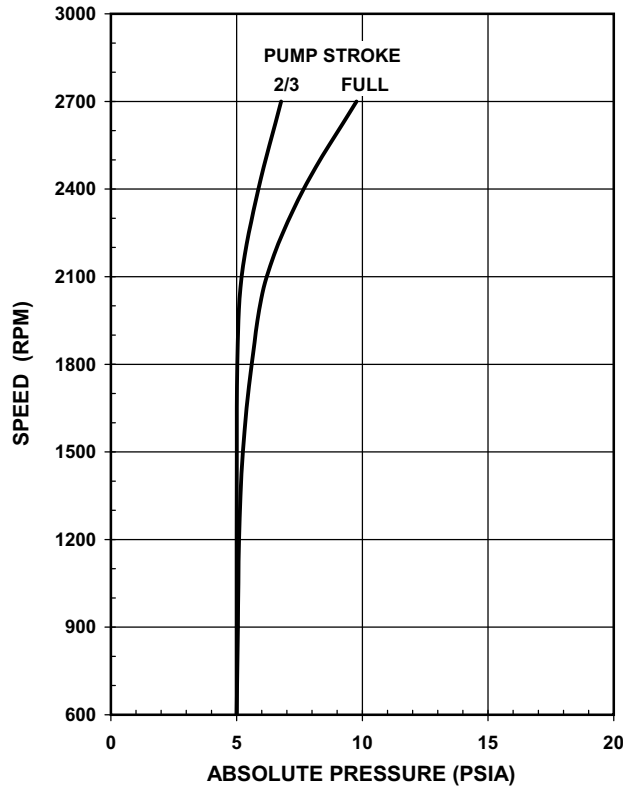

■ PVG-065

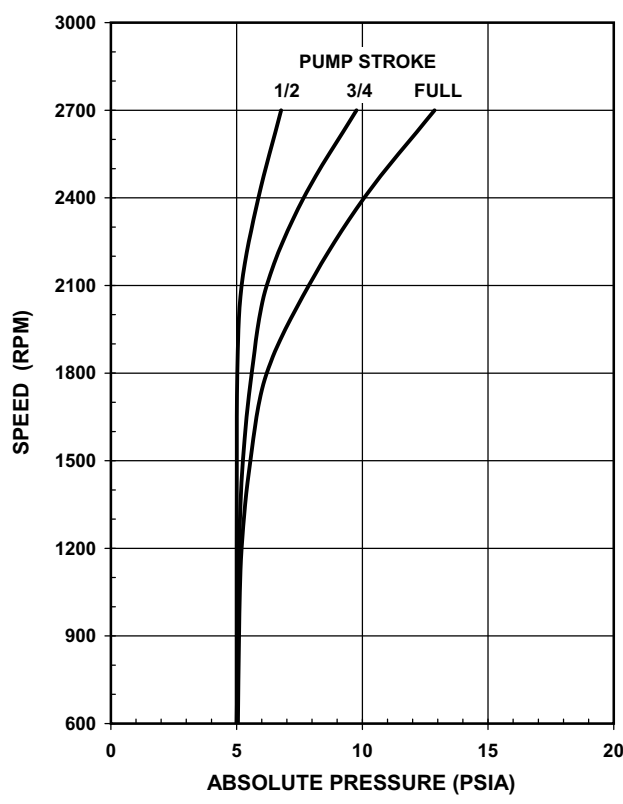

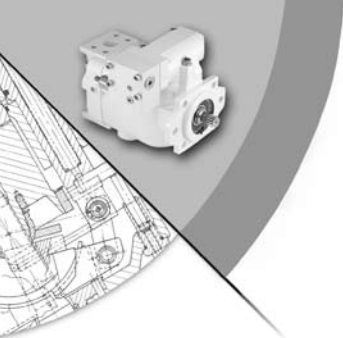

■ PVG-075

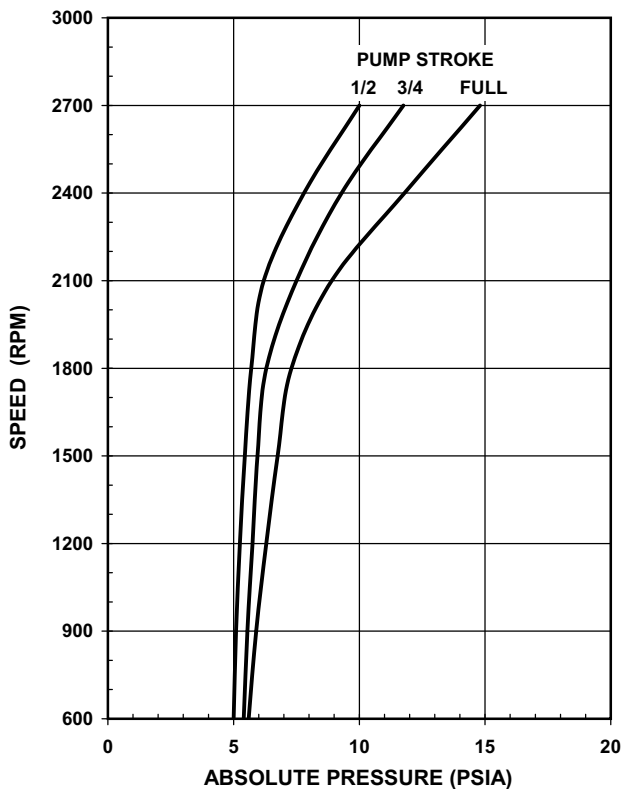

■ PVG-100

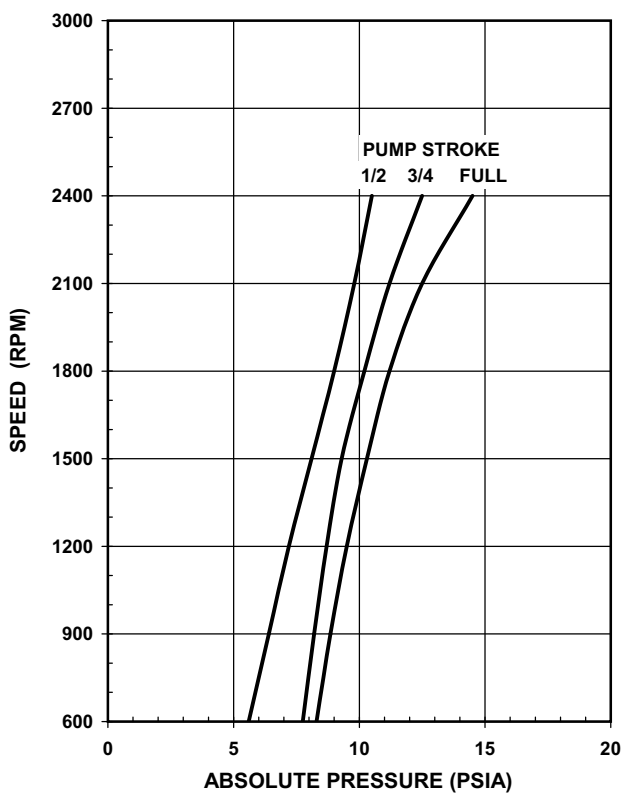

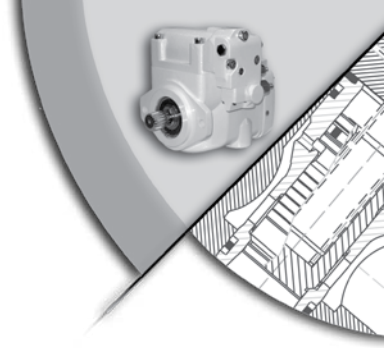

■ PVG-130

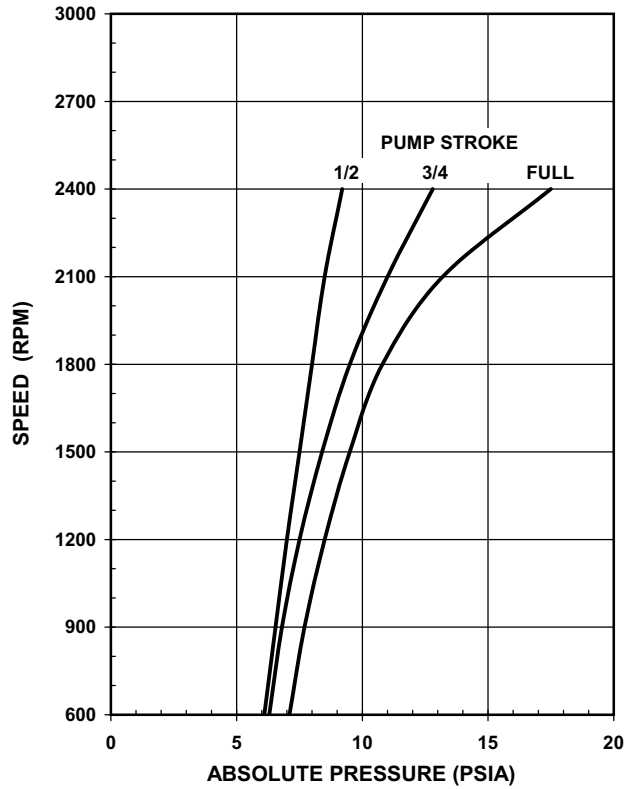

■ PVG-150

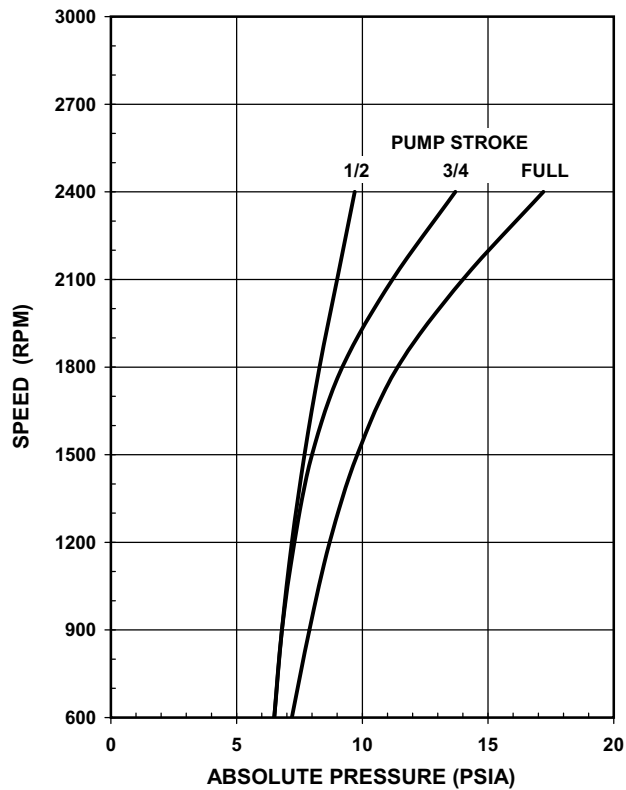

**Oilgear** Inlet Data

HOW TO ORDER - PVG 048, 065, 075

<b>BLOCK NUMBER EXPLANATION</b>	1	2	3	-	4	-	5	6	7	-	8	9	10	11	-	12	-	13	14	-	15	/	16	-	17
<b>VARIABLE PUMP EXAMPLE</b>	P	V	G	-	075	-	F1	U	V	-	L	D	F	Y	-	P	-	1NN	SN	-	AN	/	05	-	-

- 1 = UNIT**  
P = Pump
- 2 = TYPE**  
V = Variable
- 3 = DESIGN SERIES**  
G = Type
- 4 = UNIT SIZE**  
048 = 48 ml/rev. (2.93 cipr)  
065 = 65 ml/rev. (3.96 cipr)  
075 = 75 ml/rev. (4.60 cipr)
- 5 = DESIGN SERIES**  
F1 = Current
- 6 = DESIGN SERIES MODIFIER**  
U = SAE Connections & Mounting
- 7 = SEALS**  
V = Viton (Standard)  
B = Buna Nitrile  
P = EPR
- 8 = ROTATION**  
L = Left Hand (CCW)  
R = Right Hand (CW)
- 9 = VALVE PLATE TYPE**  
G = Side Ported  
D = Side Ported (thru-shaft)  
S = Rear Ported
- 10 = CONNECTION TYPE**  
F = Flange
- 11 = INPUT SHAFT TYPE**  
Y = 25-1 (SAE B-B Keyed)  
S = 25-4 (SAE B-B Spline)  
K = 22-4 (SAE B Spline)  
B = 32-1 (SAE C Keyed)  
R = 32-4 (SAE C Spline)
- 12 = CONTROL TYPE**  
N = None  
F = Fixed  
P = Pressure Compensating  
R = Solenoid Operated Volume  
V = Electrohydraulic (with feedback)

**13 = CONTROL MODIFIER**

<b>13</b>					
a	b	c	/	d	e

- For Control Type "F":**
- 13a, b, c CONTROL OPTIONS**  
075 = 75% Stroke  
100 = 100% Stroke
- For Control Type "P":**
- 13a = CONTROL OPTIONS**  
1 = Single Setting  
2 = Dual Setting  
A = Proportional Device, N.O.  
B = Proportional Device, N.C.  
C = Soft Start, N.O.  
E = Electronic Displacement Control

- 13b = SOLENOID VOLTAGE**  
N = Non-electrical Control Options  
③ 0 = 115/60 - 110/50 VAC  
③ 1 = 230/60 - 220/50 VAC  
③ 2 = 12 VDC  
3 = 24 VDC
- 13c = CONNECTOR**  
N = Non-electrical Control Options or No Connector  
R = 1/2" NPT w/o Lite  
① W = 1/2" NPT w/Lite  
S = PG-11 w/o Lite  
① L = PG-11 w/Lite
- 13d = CONTROL**  
Blank unless required option  
② F = Load Sense  
②③ G = Load Sense with Horsepower Limiter  
①③ H = Horsepower Limiter  
② K = Load Sense Plus  
②③ L = Horsepower Limiter with Load Sense Plus

**Legend**

- ① Not available with A or B Control Options
- ② Not available with pressure compensator options 2, A, B or C
- ③ Not available with pressure compensator option E

- 13e = INPUT HORSEPOWER @ 1800 RPM**  
Blank unless required option  
Example: 070 = 70 HP Input

- For Control Type "R":**
- 13a = TYPE**  
U = Two Volume Control
- 13b = SOLENOID VOLTAGE**  
N = Non-electrical Control Options  
0 = 115/60 - 110/50 VAC  
1 = 230/60 - 220/50 VAC  
2 = 12 VDC  
3 = 24 VDC
- 13c = CONNECTOR**  
R = 1/2" NPT w/o Lite  
W = 1/2" NPT w/Lite  
S = PG-11 w/o Lite  
L = PG-11 w/Lite
- For Control Type "V":**
- 13a = TYPE**  
M = Single Stage  
S = Two Stage
- 13b = SIZE**  
20 = Servo Valve Size 20 (Type M)  
25 = Servo Valve Size 25 (Type S)
- 14 = VOLUME STOPS**  
NN = No Volume Stop  
SA = Adjustable Minimum Volume Stop, Type "V" Controls Only  
SB = Adjustable Maximum & Minimum Volume Stops, Type "R" Controls Only  
SN = Adjustable Maximum Volume Stop, Not Available on Type "V" Controls
- 15 = AUXILIARY ADAPTERS**  
**Required for all thru-shaft units**  
**Blank for all non-thru-shaft units**  
AA = 50-2 (SAE A-A) Adapter & 13-4 (SAE A-A) Coupling  
AN = 82-2 (SAE A 2-Bolt) Adapter & 16-4 (SAE A) Coupling  
BB = 101-2 (SAE B 2-Bolt) Adapter & 25-4 (SAE B-B) Coupling  
BN = 101-2 (SAE B 2-Bolt) Adapter & 32-4 (SAE C) Coupling  
CP = Cover Plate  
NN = None
- 16 = GEAR PUMPS**  
Blank unless required option  
05 = 8 ml/rev. (0.488 cipr)  
07 = 11 ml/rev. (0.672 cipr)  
10 = 16 ml/rev. (0.976 cipr)  
14 = 23 ml/rev. (1.403 cipr)  
20 = 49 ml/rev. (2.015 cipr)
- 17 = SPECIAL PUMP MOD**  
Assigned by factory if necessary

<b>BLOCK NUMBER</b>	1	2	3	-	4	-	5	6	7	-	8	9	10	11	-	12	-	13	14	-	15	/	16	-	17
<b>EXPLANATION</b>																									
<b>VARIABLE PUMP EXAMPLE</b>	P	V	G	-	100	-	F1	U	V	-	L	D	F	Y	-	P	-	1NN	SN	-	AN	/	05	-	-

- 1 = UNIT**  
P = Pump
- 2 = TYPE**  
V = Variable
- 3 = DESIGN SERIES**  
G = Type
- 4 = UNIT SIZE**  
100 = 100 ml/rev. (6.00 cipr)  
130 = 130 ml/rev. (7.94 cipr)
- 5 = DESIGN SERIES**  
F1 = Current
- 6 = DESIGN SERIES MODIFIER**  
U = SAE Connections & Mounting
- 7 = SEALS**  
V = Viton (Standard)  
B = Buna Nitrile  
P = EPR
- 8 = ROTATION**  
L = Left Hand (CCW)  
R = Right Hand (CW)
- 9 = VALVE PLATE TYPE**  
G = Side Ported  
D = Side Ported (thru-shaft)  
S = Rear Ported
- 10 = CONNECTION TYPE**  
F = Flange
- 11 = INPUT SHAFT TYPE**  
Y = 38-1 (SAE C-C Keyed)  
Z = 38-1 (SAE C-C Keyed),  
1" Shorter than "Y"  
S = 38-4 (SAE C-C Spline)  
K = 32-4 (SAE C Spline)  
R = 44-4 (SAE D Spline)
- 12 = CONTROL TYPE**  
N = None  
F = Fixed  
P = Pressure Compensating  
R = Solenoid Operated Volume  
V = Electrohydraulic  
(with feedback)

**13 = CONTROL MODIFIER**

<b>13</b>				
a	b	c	/	d e

**For Control Type "F":**

**13a, b, c CONTROL OPTIONS**

- 075 = 75% Stroke
- 100 = 100% Stroke

**For Control Type "P":**

**13a = CONTROL OPTIONS**

- 1 = Single Setting
- 2 = Dual Setting
- A = Proportional Device, N.O.
- B = Proportional Device, N.C.
- C = Soft Start, N.O.
- E = Electronic Displacement Control

**13b = SOLENOID VOLTAGE**

- N = Non-electrical Control Options
- ③ 0 = 115/60 - 110/50 VAC
- ③ 1 = 230/60 - 220/50 VAC
- ③ 2 = 12 VDC
- ③ 3 = 24 VDC

**13c = CONNECTOR**

- N = Non-electrical Control Options or No Connector
- R = 1/2" NPT w/o Lite
- ① W = 1/2" NPT w/Lite
- S = PG-11 w/o Lite
- ① L = PG-11 w/Lite

**13d = CONTROL**

- Blank unless required option
- ② F = Load Sense
- ②③ G = Load Sense with Horsepower Limiter
- ①③ H = Horsepower Limiter
- ② K = Load Sense Plus
- ②③ L = Horsepower Limiter with Load Sense Plus

**Legend**

- ① Not available with A or B Control Options
- ② Not available with pressure compensator options 2, A, B or C
- ③ Not available with pressure compensator option E

**13e = INPUT HORSEPOWER @ 1800 RPM**

- Blank unless required option
- Example: 070 = 70 HP Input

**For Control Type "R":**

**13a = TYPE**

- U = Two Volume Control

**13b = SOLENOID VOLTAGE**

- N = Non-electrical Control Options
- 0 = 115/60 - 110/50 VAC
- 1 = 230/60 - 220/50 VAC
- 2 = 12 VDC
- 3 = 24 VDC

**13c = CONNECTOR**

- R = 1/2" NPT w/o Lite
- W = 1/2" NPT w/Lite
- S = PG-11 w/o Lite
- L = PG-11 w/Lite

**For Control Type "V":**

**13a = TYPE**

- M = Single Stage
- S = Two Stage

**13b = SIZE**

- 20 = Servo Valve Size 20 (Type M)
- 25 = Servo Valve Size 25 (Type S)

**14 = VOLUME STOPS**

- NN = No Volume Stop
- SA = Adjustable Minimum Volume Stop, Type "V" Controls Only
- SB = Adjustable Maximum & Minimum Volume Stops, Type "R" Controls Only
- SN = Adjustable Maximum Volume Stop, Not Available on Type "V" Controls

**15 = AUXILIARY ADAPTERS**

**Required for all thru-shaft units**  
**Blank for all non-thru-shaft units**

- AA = 50-2 (SAE A-A) Adapter & 13-4 (SAE A-A) Coupling
- AN = 82-2 (SAE A 2-Bolt) Adapter & 16-4 (SAE A) Coupling
- BB = 101-2 (SAE B 2-Bolt) Adapter & 25-4 (SAE B-B) Coupling
- BN = 101-2 (SAE B 2-Bolt) Adapter & 32-4 (SAE C) Coupling
- CN = 127-2 (SAE C 2-Bolt) Adapter & 32-4 (SAE C) Coupling
- CP = Cover Plate
- NN = None

**16 = GEAR PUMPS**

- Blank unless required option
- 05 = 8 ml/rev. (0.488 cipr)
- 07 = 11 ml/rev. (0.672 cipr)
- 10 = 16 ml/rev. (0.976 cipr)
- 14 = 23 ml/rev. (1.403 cipr)
- 20 = 49 ml/rev. (2.015 cipr)

**17 = SPECIAL PUMP MOD**

- Assigned by factory if necessary

## HOW TO ORDER - PVG 150

<b>BLOCK NUMBER EXPLANATION</b>	1	2	3	-	4	-	5	6	7	-	8	9	10	11	-	12	-	13	14	-	15	/	16	-	17
<b>VARIABLE PUMP EXAMPLE</b>	P	V	G	-	150	-	A1	U	V	-	L	D	F	Y	-	P	-	1NN	SN	-	A2	/	05	-	-

- 1 = UNIT**  
P = Pump
- 2 = TYPE**  
V = Variable
- 3 = DESIGN SERIES**  
G = Type
- 4 = UNIT SIZE**  
150 = 150 ml/rev. (9.16 cipr)
- 5 = DESIGN SERIES**  
A1 = Current
- 6 = DESIGN SERIES MODIFIER**  
U = SAE Connections & Mounting
- 7 = SEALS**  
V = Viton (Standard)  
B = Hydrogenated Buna Nitrile  
P = EPR
- 8 = ROTATION**  
L = Left Hand (CCW)  
R = Right Hand (CW)
- 9 = VALVE PLATE TYPE**  
G = Side Ported  
D = Side Ported (thru-shaft)
- 10 = CONNECTION TYPE**  
F = Flange
- 11 = INPUT SHAFT TYPE**  
L = 44-4 (SAE D Spline)  
Y = 44-1 (SAE D Keyed)
- 12 = CONTROL TYPE**  
P = Pressure Compensating  
F = Fixed  
V = Electrohydraulic (with feedback)

### 13 = CONTROL

<b>13</b>					
a	b	c	/	d	e

#### For Control Type "F":

#### 13a, b, c CONTROL OPTIONS

075 = 75% Stroke  
100 = 100% Stroke

#### For Control Type "P":

#### 13a = CONTROL OPTIONS

- 1 = Single Setting
- 2 = Dual Setting
- A = Proportional Device, N.O.
- B = Proportional Device, N.C.
- C = Soft Start, N.O.
- E = Electronic Displacement Control

#### 13b = SOLENOID VOLTAGE

- N = Non-electrical Control Options
- ③ 0 = 115/60 - 110/50 VAC
- ③ 1 = 230/60 - 220/50 VAC
- ③ 2 = 12 VDC
- 3 = 24 VDC

#### 13c = CONNECTOR

- N = Non-electrical Control Options or No Connector
- R = 1/2" NPT w/o Lite
- ① W = 1/2" NPT w/Lite
- S = PG-11 w/o Lite
- ① L = PG-11 w/Lite

#### 13d = CONTROL MODIFIER

- Blank unless required option
- ② F = Load Sense
- ②③ G = Load Sense with Horsepower Limiter
- ①③ H = Horsepower Limiter
- ② K = Load Sense Plus
- ②③ L = Horsepower Limiter with Load Sense Plus

#### Legend

- ① Not available with A or B Control Options
- ② Not available with pressure compensator options 2, A, B or C
- ③ Not available with pressure compensator option E

#### 13e = INPUT HORSEPOWER @ 1800 RPM

Blank unless required option  
Example: 070 = 70 HP Input

#### For Control Type "V":

#### 13a = TYPE

- M = Single Stage
- S = Two Stage

#### 13b = SIZE

- 20 = Servo Valve Size 20 (Type M)
- 25 = Servo Valve Size 25 (Type S)

#### 14 = VOLUME STOPS

- NN = No Volume Stop
- SA = Adjustable Minimum Volume Stop, Type "V" Controls Only
- SN = Adjustable Maximum Volume Stop, Not Available on Type "V" Controls

#### 15 = AUXILIARY ADAPTERS

Required for all thru-shaft units  
Blank for all non-thru-shaft units

- AA = 50-2 (SAE A-A) Adapter & Coupling
- A2 = 82-2 (SAE A 2-Bolt) Adapter & 16-4 (SAE A) Coupling
- B2 = 101-2 (SAE B 2-Bolt) Adapter & 22-4 (SAE B) Coupling
- B4 = 101-4 (SAE B 4-Bolt) Adapter & 22-4 (SAE B) Coupling
- C2 = 127-2 (SAE C 2-Bolt) Adapter & 32-4 (SAE C) Coupling
- C4 = 127-4 (SAE C 4-Bolt) Adapter & 32-4 (SAE C) Coupling
- D4 = 152-4 (SAE D 4-Bolt) Adapter & 44-4 (SAE D) Coupling
- CP = Cover Plate
- NN = None
- 25-4 (SAE B-B) & 38-4 (SAE C-C) Couplings also available as special order.

#### 16 = GEAR PUMPS

- Blank unless required option
- 05 = 8 ml/rev. (0.488 cipr)
- 07 = 11 ml/rev. (0.672 cipr)
- 10 = 16 ml/rev. (0.976 cipr)
- 14 = 23 ml/rev. (1.403 cipr)
- 20 = 49 ml/rev. (2.015 cipr)

#### 17 = SPECIAL PUMP MOD

Assigned by factory if necessary





Installation Drawings	048, 065, 075 Series F1	100, 130 Series F1	150 Series A1
<b>Pumps</b>			
Basic Pump Rear Ported	DS-47952	DS-47942	
Basic Pump Side Ported (Top and Bottom)	DS-47953	DS-47943	DS-47375
Basic Pump Thru Shaft	DS-47954	DS-47944	DS-47376
Dual Pump Adapter - 2 Bolt	DS-47958	DS-47946	DS-47387
Dual Pump Adapter - 4 Bolt			DS-47388
<b>Controls</b>			
Fixed Delivery	DS-47549	DS-47548	
P-1NN Single Pressure Compensator	DS-47551	DS-47541	DS-47377
P-1NN/F Single Pressure Compensator w/Load Sense	DS-47552	DS-47542	DS-47378
P-1NN/H Single Pressure Compensator w/Horsepower Limiter	DS-47553	DS-47543	DS-47380
P-1NN/G Single Pressure Compensator w/Horsepower Limiter w/Load Sense	DS-47554	DS-47544	DS-47379
P-1NN/K Single Pressure Compensator w/Load Sense Plus	DS-47621	DS-47350	DS-47385
P-1NN/L Single Pressure Compensator w/Horsepower Limiter w/Load Sense Plus	DS-47622	DS-47351	DS-47386
P-C Single Pressure Soft Start	DS-47557	DS-47547	DS-47382
P-CXX/H Single Pressure Soft Start w/Horsepower Limiter	DS-47618	DS-47521	DS-47389
P-2 Dual Pressure Compensator	DS-47555	DS-47545	DS-47381
P-2XX/H Dual Pressure Compensator w/Horsepower Limiter	DS-47617	DS-47520	DS-47390
P-ANX (N.O.) or P-BNX (N.C.) Electronic Proportional Pressure Compensator	DS-47556	DS-47546	DS-47383
V-S 2-Stage Servo Valve	DS-47615	DS-47719	
V-M Single Stage Servo Valve	DS-47616	DS-47522	
P-E Electronic Displacement Control (EDC)	DS-47619	DS-47860	DS-47384
P-E/F Electronic Displacement Control (EDC) W/Load Sense	DS-47620	DS-47861	DS-47389

For additional technical information refer to the Application Guidelines bulletin 847019.

Information in this bulletin subject to change without notice. Current versions of the documents referenced in this bulletin may have a letter at the end to denote the revision level. The latest release of any of any document, including this one, can be found on the Oilgear website or by contacting your Oilgear representative.

# Oilgear

**World Headquarters**  
**The Oilgear Company**

2300 South 51st Street Milwaukee, WI USA 53219  
phone: 414/327-1700 fax: 414/327-0532

[www.oilgear.com](http://www.oilgear.com)

For more information about your application or the products in this brochure, please contact your nearest Oilgear facility.

**FAMCO**  
هایپرمنعت



**BRAZIL**  
Oilgear do Brazil Hydraulica Ltd.

**CANADA**  
The Oilgear Company

**CHINA**  
Oilgear China Co. Ltd.

**FRANCE**  
Oilgear Towler S.A.

**GERMANY**  
Oilgear Towler GmbH

**INDIA**  
Oilgear Towler Polyhydron Pvt. Ltd.  
Towler Automation Pvt. Ltd.

**ITALY**  
Oilgear Towler S.r.l.

**JAPAN**  
The Oilgear Japan Company

**KOREA**  
Oilgear Towler Korea Co. Ltd.

**MEXICO**  
Oilgear Mexicana S.A. De C.V.

**SPAIN**  
Oilgear Towler S.A.

**TAIWAN**  
Oilgear Towler Taiwan Co. Ltd.

**UNITED KINGDOM**  
Oilgear Towler Ltd.

**UNITED STATES**  
The Oilgear Company  
Olmsted Products  
Clover Industries

Bulletin 47019-J  
Revised October 2010  
Printed in USA

