

# K SINGLE-IMPELLER

## SINGLE-IMPELLER ELECTRIC PUMPS



### TECHNICAL DATA

**Operating range:**

from 1,8 to 96 m<sup>3</sup>/h, with head up to 62 metres.

**Pumped liquid:** clean, free of solids and abrasives, non-viscous, non-aggressive, non-crystallised and chemically neutral, with properties similar to water.

**Liquid temperature range:**

K 20/41, K 30/70, K 30/100, K 36/100

K 12/200, K 36/200, K 40/200 :

from -10 °C to +50 °C

Remainder of the range:

from -15 °C to +110 °C

**Maximum ambient temperature:** +40°C

**Maximum operating pressure:**

K 20/41, K 30/70, K 30/100, K 36/100, K 12/200, K 14/400 : 6 bar (600 kPa)

K 36/200, K 40/200, K 55/200, K 11/500, K 18/500, K 28/500 : 8 bar (800 kPa)

K 40/400, K 50/400, K 30/800, K 40/800, K 50/800,

K 20/1200, K 25/1200, K 35/1200

: 10 bar (1000 kPa)

**Protection class:**

IP 44 (IP 55 for 2,2 - 3 - 4 - 5,5 - 7,5 - 9,2 - 11 kW motors)

**Protection class at the terminal board:** IP 55

**Insulation class:** F

**Standard voltage:**

single-phase 220-240 V / 50 Hz

three-phase 230-400 V / 50 Hz up to 4 kW included - 400 V Δ 50 Hz from 5,5 kW

**Installation:** horizontal or vertical position, provided that the motor is always above the pump.

**Special executions on requests:** alternative voltages and frequencies.

### APPLICATIONS

Single-impeller centrifugal pump suitable for domestic, civil, industrial and agricultural systems, and for decanting, mixing and irrigation uses.

### CONSTRUCTION FEATURES OF THE PUMP

Pump body and motor support in cast iron.

Technopolymer or cast iron impeller, as per the TECHNICAL DATA table.

Carbon/ceramic mechanical seal.

### CONSTRUCTION FEATURES OF THE MOTOR

Closed asynchronous type, external ventilation cooling.

Rotor running on ball bearings, oversized to ensure low noise and durability.

Standard built-in thermo-amperometric protection. Capacitor permanently fitted on single phase versions.

For the protection of the three-phase motor, we recommend the use of remote overload cut-outs, in compliance with current local regulations.

Construction according to CEI 2-3.

IE2 motors as standard, from 0,75 kW to 5,5 kW - IE3 ≥ 7,5 kW

# K SINGLE-IMPELLER

## SINGLE-IMPELLER ELECTRIC PUMPS

### MATERIALS

No.	PARTS*	MATERIALS	MODELS
1	PUMP BODY	CAST IRON 200 UNI ISO 185	
3	SUPPORT	CAST IRON 200 UNI ISO 185	
4	IMPELLER	TECHNOPOLYMER A	20/41; K 30/70; K 30/100; K 36/100; K 12/200; K 36/200; K 40/200;
		TECHNOPOLYMER B	K 55/200
		CAST IRON 200 UNI ISO 185	K 14/400; K 11/500; K 18/500; K 28/500; K 40/400; K 50/400; K 30/800; K 40/800; K 50/800; K 20/1200; K 25/1200; K 35/1200;
7	SHAFT WITH ROTOR	AISI 416 STAINLESS STEEL X12CRS13 UNI 6900/71	K 20/41; K 30/70; K 12/200
		AISI 303 STAINLESS STEEL X10CRNIS 1089 UNI 6900/71	K 30/100; K 36/100; K 36/200; K 40/200; K 55/200; K14/400; K 11/500; K 18/500; K 28/500
		AISI 304 STAINLESS STEEL X5CRNI 1810 UNI 6900/71	K 40/400; K 50/400; K 30/800; K 40/800; K 50/800; K 20/1200; K 25/1200; K 35/1200;
16	MECHANICAL SEAL	CARBON / CERAMIC	
28	OR RING	NBR RUBBER	
		EPDM RUBBER	K 36/200; K 40/200; K 55/200; K 14/400; K 11/500; K 18/500; K 28/500; K 30/800; K 40/800; K 50/800; K 20/1200; K 25/1200; K 35/1200;

\* In contact with the liquid

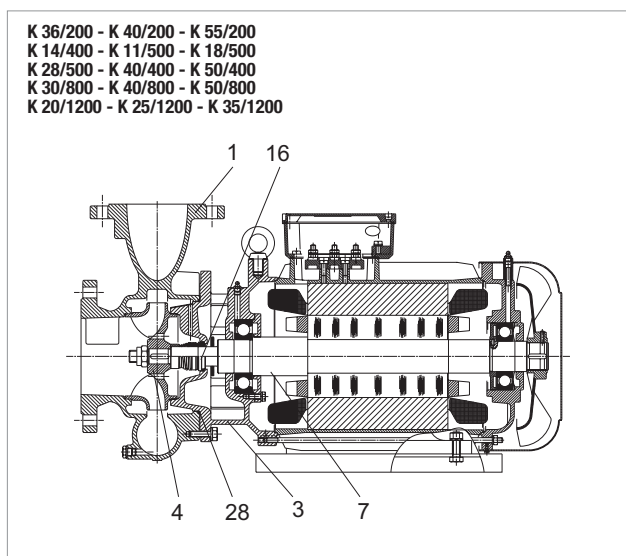
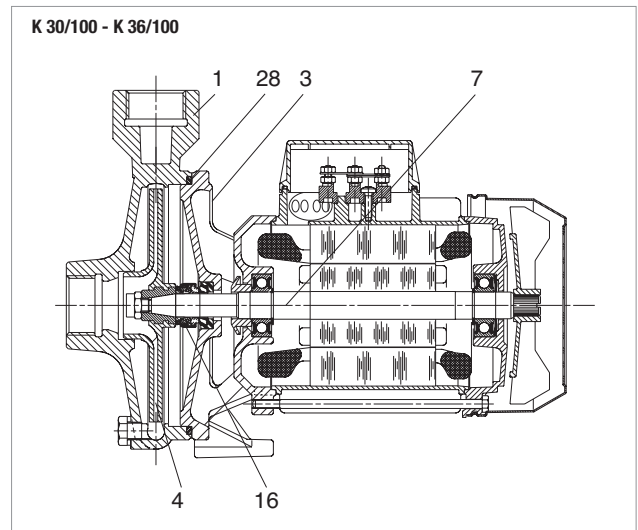
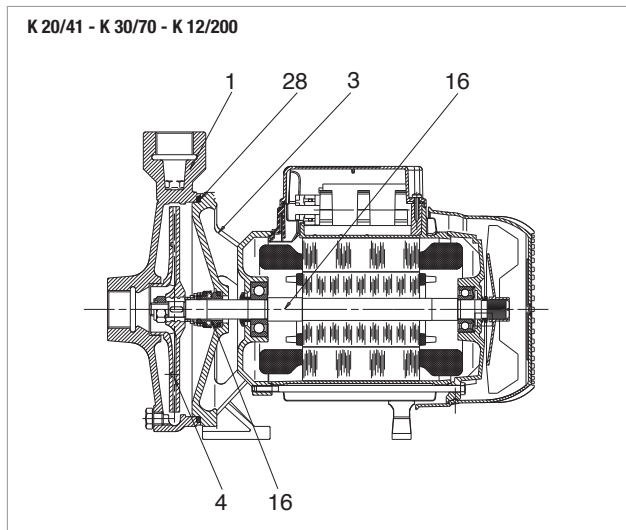

DAB PUMPS reserves the right to make modifications without notice.

# K SINGLE-IMPELLER RANGE

## ELECTRIC PUMPS

### PERFORMANCE RANGE

The performance curves are based on kinematic viscosity values = 1 mm<sup>2</sup>/s and density equal to 1000 kg/m<sup>3</sup>. Curve tolerance according to ISO 9906.

### GRAPHIC SELECTION TABLE

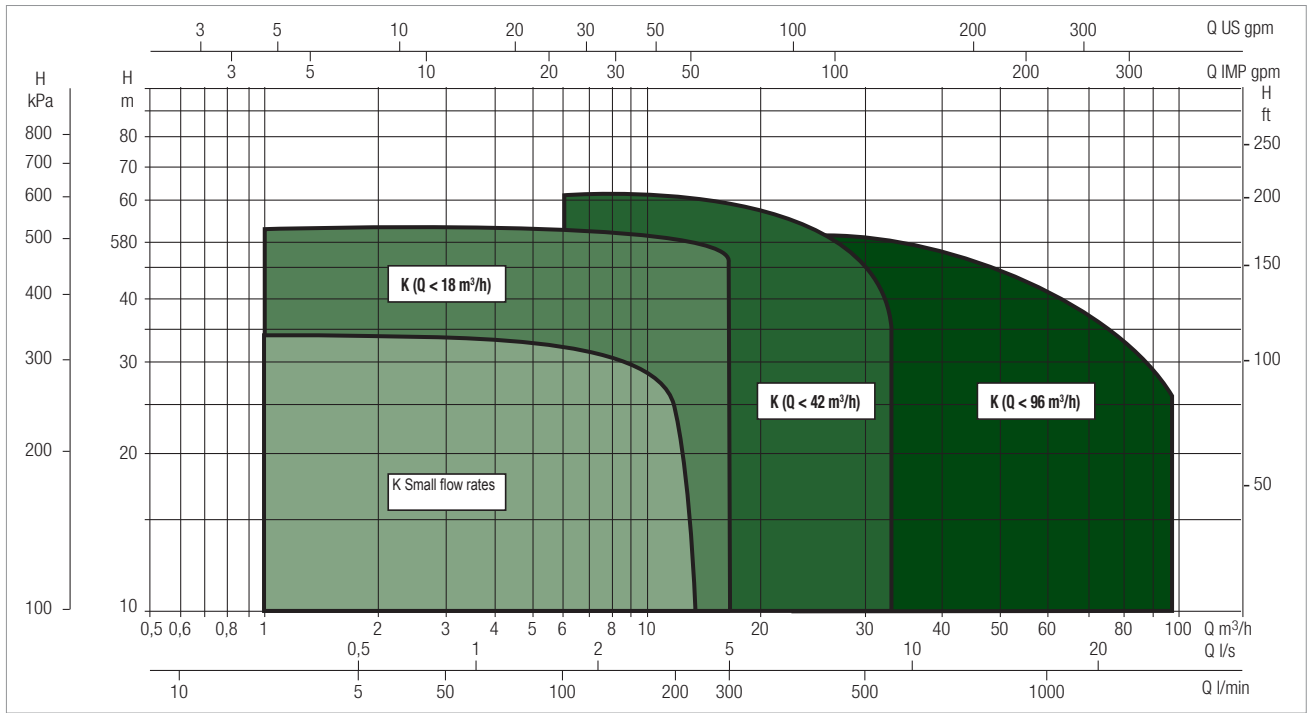

### SELECTION TABLE

MODEL	Q=																					
	0	1.8	2.4	3.6	4.8	6	7.2	9	9.6	10.8	12	15	18	24	30	36	42	60	72	84	96	
	Q=																					
	m <sup>3</sup> /h																					
	Q=																					
	l/min																					
K 20/41 M-T	H (m)	22	20.3	19.4	16.9	13.6	8.3															
K 30/70 M-T		31.8	29.5	28.9	27	24.2	19.8	13.5														
K 30/100 M-T		29.2		29	28.8	28	26.8	25.3	22.5	21.5	18.5											
K 36/100 M-T		34.9		34.8	34.6	34	33	32	29.8	29	26.5											
K 12/200 M-T		18.7	18.2	18	17.9	17.7	17.4	17	16.1	15.8	14.9	14	11.2	7.7								
K 36/200 T		36.6				36	35.5	35	34	33.3	32.5	31.5	28	23.5								
K 40/200 T		41.3				41	40.5	40	39	38.8	38	37	33.5	29								
K 55/200 T		54				54	53.9	53.2	53	52	51.5	48.5	45									
K 14/400 M-T		19									18.8	18.5	18	16.3	13.8	10						
K 11/500 T		25.1									26	25.6	25.2	22.9	18.7	13.7	7.7					
K 18/500 T		30.9									32	31.8	30	28.5	25	19.3	13.1					
K 28/500 T		35.4									36.6	36.1	35.6	33.2	30.1	24.7	18.1					
K 40/400 T		50.5									49	48	45	37	24							
K 50/400 T		62									61	60	59	54.5	46							
K 30/800 T		44												42	40	38	35	21.5				
K 40/800 T		51.5												50	48	47	43.5	32.5	21			
K 50/800 T		58												56.5	55	53.5	51	41	31			
K 20/1200 T		37.5												36.5	36	35	34	30	26	21	15	
K 25/1200 T		40.7												39	38.5	38	37	33.5	30	25	18	
K 35/1200 T		45														43	42.5	38.5	35	31.5	27	

## K 25/1200 - SINGLE-IMPELLER CENTRIFUGAL ELECTRIC PUMPS FOR WATER SUPPLY IN DOMESTIC, CIVIL, AND INDUSTRIAL ENVIRONMENTS

Pumped liquid temperature range: from -10 °C to +50°C - Maximum ambient temperature: +40°C

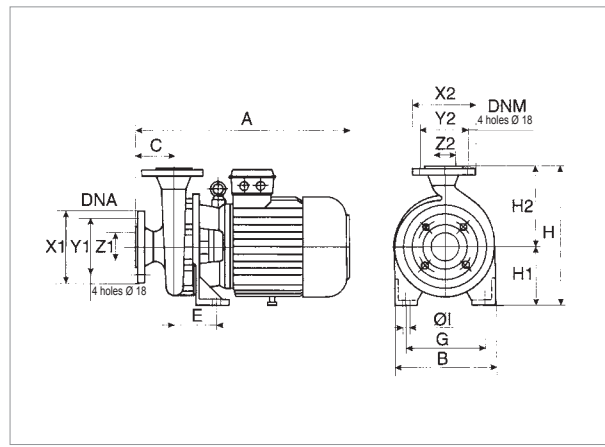

See hydraulic efficiency details on page 291.  
The performance curves are based on kinematic viscosity values = 1 mm<sup>2</sup>/s and density equal to 1000 kg/m<sup>3</sup>. Curve tolerance according to ISO 9906.

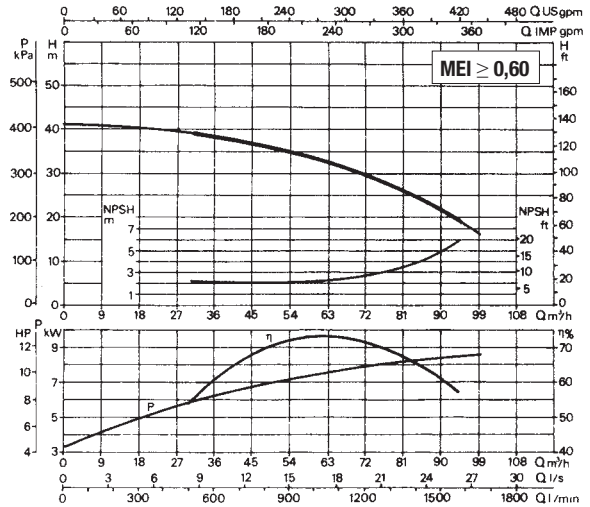

MODEL	POWER INPUT 50 Hz	P1 MAX kW	P2 NOMINAL		In A	MOTOR TYPE	I st. A	rpm n. 1/min.
			kW	HP				
<b>K 25/1200 T</b>	3 x 400 V ~1	9.1	9.2	12.5	17.3	IE3	135	2910

MODEL	A	B	C	E	G	ØI	H	H1	H2	DNA			DNM			PACKING DIMENSIONS			VOLUME (m <sup>3</sup> )	WEIGHT kg
										x1	y1	z1	x2	y2	z2	L/A	L/B	H		
<b>K 25/1200</b>	600	273	100	110	212	14	385	160	225	200	160	80	185	145	65	680	330	572	0.128	94

1 star start-up possible (★)